



APPLICATION GUIDE TO IECC-2024

A SUPPLEMENTAL GUIDE TO CODE
REVISIONS IMPACTING LIGHTING CONTROL

TABLE OF CONTENTS

IECC APPLICATION GUIDE

NX Lighting Controls' advanced systems and lighting controls offer a comprehensive portfolio of simple, scalable and seamless solutions for indoor and outdoor applications from a single partner. Our advanced lighting control technologies provide intuitive and flexible deployment options to meet code, enhance comfort, increase energy savings and improve operating efficiency for enterprises of any size. NX Lighting Controls' product suite includes distributed and centralized, wired and wireless systems, luminaire integrated sensors, color tuning controls, panels, occupancy sensors, photocell sensors, and emergency relays.



04	IECC Code Requirements for Typical Building Spaces
06	Code Summary
14	How to Use This Guide
16	Enclosed Office or Open Office <300ft ²
18	Open Office >300ft ²
20	Conference Room
22	Classroom
24	Lobby
26	Elevator Lobby
28	Corridor
29	Public Restroom
30	Private or Single Restroom
32	Warehouse
34	Gymnasium
35	Interior Level Parking Garage, Exterior Parking Lot
36	Site With Parking Lot
37	Exterior Parking Lot, Site With Parking Lot
40	Networking Overview
42	Emergency Lighting
44	Mobile App
46	Product Catalog
54	Support and Education



IECC establishes minimum requirements for energy-efficient buildings using prescriptive and performance related provisions. For more information, visit <https://codes.iccsafe.org>. The recommendations in this document are based on our understanding and interpretation of the code. In order to ensure full compliance, please reference the official published code.

IECC CODE REQUIREMENTS FOR TYPICAL BUILDING SPACES

IECC APPLICATION GUIDE



	INTERIOR CONTROL				RECEPTACLE PLUG LOAD CONTROL	PARKING GARAGE CONTROLS	EXTERIOR CONTROLS
Control Requirement	Occupancy Sensor	Timeclock	Dimming Controls	Daylight Responsive Controls	Receptacle (Plug load control)	Interior Parking Control	Exterior Controls
Code Provision	C405.2.1	C405.2.2	C405.2.2.2	C405.2.4	C405.2.12	C405.2.9	C405.2.7
Code Summary	Occupancy Sensor controls shall be installed to control lights. Shall be manual on or not more than 50%. Shall turn off within 20 minutes after occupancy.	Areas without occupancy sensor control shall be provided with timeswitch controls.	Where not provided with occupancy sensor controls lighting shall be provided with light-reduction controls. Spaces shall have a manual control. Luminaries controlled by daylight responsive controls are exempt.	Daylight responsive controls are required in spaces of more than 150 Watts of primary sidelight or top light daylight zones. Additionally, within 300 Watts of a sidelight zone. Shall dim continuously from full to 15% of full light output. Secondary daylight zones shall extend 2 times the height of the fenestration.	At least 50% of all 125V, 15 and 20 amp receptacles & at least 25% of branch circuit feeders installed for modular furniture not shown on the construction documents.	Shall be controlled by an occupants sensor or time control. Reducing luminaire by not less the 30%with no activity for 20 minutes. Does not include areas with 1.5 lumens or less. 20 ft within perimeter wall will have daylight responsive control by 50%. Entrances and exits shall be separately controlled.	Lighting shall be automatically turned off when daylight is present. Building Façade and landscape lighting shall automatically shut off no later than 1 hr. after business closing to not earlier than 1 hr. before business opening. All other exterior lighting shall be reduced by 50% either midnight to 6 am or during any time with no activity after 15 minutes or 1 hr. after business to 1 hr. before business.
Enclosed Office	•			•	•		
Open Office	•			•	•		
Conf. Meeting, Multi- Purpose	•			•	•		
Classroom, Lecture Hall, Training	•			•	•		
Lobby	•			•	•		
Corridor	•			•			
Restroom	•			•			
Locker Rooms		•	•	•			
Warehouse/Storage	•			•			
Parking Area, Interior	• OR	•				•	
Exterior Lighting	• OR	•					•

CLASSROOM / LECTURE HALL / TRAINING ROOM

	Code Provision	Minimum Control Type	Requirement
OCC SENSOR CONTROL	C405.2.1	Occupancy Sensor shall incorporate manual control to allow occupants to turn off lights.	Automatically shuts off lighting power after vacancy of 20 minutes or less. Shall be manually on or automatically on to no more than 50%.
DAYLIGHT RESPONSE CONTROL	C405.2.4	Full range dimming controllers with daylight sensors in primary and secondary daylight zone.	Daylight responsive controls are required in spaces of more than 150 Watts of primary sidelight or top light daylight zones. Additionally, within 300 Watts of a sidelight zone will have a secondary daylight zone in from the window 1 times the height of the window to the floor. Shall dim continuously from full to 20% of full light output. Secondary daylight zones shall extend 2 times the height of the fenestration.
RECEPTACLE CONTROL	C405.10	Occupancy sensor turns lights off within 20 minutes of all occupants leaving.	50% of all 125 V, 15 & 20-amp receptacles. Plug-in devices shall NOT comply—MUST be hardwired Receptacle.

CONFERENCE / MEETING / MULTI-PURPOSE ROOM

	Code Provision	Minimum Control Type	Requirement
OCC SENSOR CONTROL	C405.2.1		Automatically shuts off lighting power after vacancy of 20 minutes or less. Manual or auto to <50%.
DAYLIGHT RESPONSE CONTROL	C405.2.4	Full range dimming controllers with daylight sensors in primary and secondary daylight zone.	Daylight responsive controls are required in spaces of more than 150 Watts of primary sidelight or top light daylight zones. Additionally, within 300 Watts of a sidelight zone will have a secondary daylight zone in from the window 1 times the height of the window to the floor. Shall dim continuously from full to 20% of full light output. Secondary daylight zones shall extend 2 times the height of the fenestration.
RECEPTACLE CONTROL	C405.2.12	Occupancy sensor turns lights off within 20 minutes of all occupants leaving.	50% of all 125 V, 15 & 20-amp receptacles. Plug-in devices shall NOT comply—MUST be hardwired Receptacle.

ENCLOSED OFFICE OR OPEN OFFICE <300ft²

	Code Provision	Minimum Control Type	Requirement
OCC SENSOR CONTROL	C405.2.1	Occupancy Sensor shall incorporate manual control to allow occupants to turn off lights.	Automatically shuts off lighting power after vacancy of 20 minutes or less. Shall be manually on or automatically on to no more than 50%.
DAYLIGHT RESPONSE CONTROL	C405.2.4	Full range dimming controllers with daylight sensors in primary and secondary daylight zones.	Daylight responsive controls are required in spaces of more than 150 Watts of primary sidelight or top light daylight zones. Additionally, within 300 Watts of a sidelight zone will have a secondary daylight zone in from the window 1 times the height of the window to the floor. Shall dim continuously from full to 20% of full light output. Secondary daylight zones shall extend 2 times the height of the fenestration.
RECEPTACLE CONTROL	C405.11	Occupancy sensor turns off within 20 minutes of all occupants leaving.	50% of all 125 V, 15 & 20-amp receptacles. Plug-in devices shall NOT comply—MUST be hardwired Receptacle.

OPEN OFFICE > 300ft²

	Code Provision	Minimum Control Type	Requirement
OCC SENSOR CONTROLS	C405.2.1	Occupancy sensor in zones controlled separately of no more than 600 ft².	Each zone permitted to turn on automatically upon occupancy. Adjacent zones are permitted to turn on to no more than 20%. Zones will turn off within 20 minutes after all zones are unoccupied.
TIME CLOCK CONTROL	C405.2.2	Minimum 7 day clock with holiday “shutoff”. Program and time backup for minimum 10 hour power loss. With override switch not to control more than 5000 ft².	Automatically turns lights off when space is scheduled to be unoccupied.
DAYLIGHT RESPONSE CONTROL	C405.2.4	Full range dimming controllers with daylight sensors in primary and secondary daylight zones.	Daylight responsive controls are required in spaces of more than 150 Watts of primary sidelight or top light daylight zones. Additionally, within 300 Watts of a sidelight zone will have a secondary daylight zone in from the window 1 times the height of the window to the floor. Shall dim continuously from full to 20% of full light output. Secondary daylight zones shall extend 2 times the height of the fenestration.
RECEPTACLE CONTROL	C405.11	Occupancy sensor turns off within 20 minutes of all occupants leaving.	50% of all 125 V, 15 & 20-amp receptacles. Plug-in devices shall NOT comply—MUST be hardwired Receptacle.

CORRIDOR

	Code Provision	Minimum Control Type	Requirement
OCC SENSOR CONTROL	C405.2.1	Occupancy Sensor shall incorporate manual control not required.	Automatically shuts off lighting power after vacancy of 20 minutes or less. Full Automatic on permitted.
DAYLIGHT RESPONSE CONTROL	C405.2.4	Full range dimming controllers with daylight sensors in primary and secondary daylight zones.	Daylight responsive controls are required in spaces of more than 150 Watts of primary sidelight or top light daylight zones. Additionally, within 300 Watts of a sidelight zone will have a secondary daylight zone in from the window 1 times the height of the window to the floor. Shall dim continuously from full to 20% of full light output. Secondary daylight zones shall extend 2 times the height of the fenestration.

RESTROOM

	Code Provision	Minimum Control Type	Requirement
OCC SENSOR CONTROLS	C405.2.1	Occupancy Sensor shall incorporate manual control to allow occupants to turn off lights.	Automatically shuts off lighting power after vacancy of 20 minutes or less. Shall be manually on or automatically on to no more than 50%.
DAYLIGHT RESPONSE CONTROL	C405.2.4	Full range dimming controllers with daylight sensors in primary and secondary daylight zones.	Daylight responsive controls are required in spaces of more than 150 Watts of primary sidelight or top light daylight zones. Additionally, within 300 Watts of a sidelight zone will have a secondary daylight zone in from the window 1 times the height of the window to the floor. Shall dim continuously from full to 20% of full light output. Secondary daylight zones shall extend 2 times the height of the fenestration.

STORAGE ROOM

	Code Provision	Minimum Control Type	Requirement
OCC SENSOR CONTROL	C405.2.1	Occupancy Sensor shall incorporate manual control to allow occupants to turn off lights.	Automatically shuts off lighting power after vacancy of 20 minutes or less. Shall be manually on or automatically on to no more than 50%.
DAYLIGHT RESPONSE CONTROL	C405.2.4	Full range dimming controllers with daylight sensors in primary and secondary daylight zones.	Daylight responsive controls are required in spaces of more than 150 Watts of primary sidelight or top light daylight zones. Additionally, within 300 Watts of a sidelight zone will have a secondary daylight zone in from the window 1 times the height of the window to the floor. Shall dim continuously from full to 20% of full light output. Secondary daylight zones shall extend 2 times the height of the fenestration.

IECC-2024 CHANGES FROM IECC-2021 CODE

Code provision sections have changed. Below are the new sections under C405.2 and their changes.

C405.2.1 – OCCUPANCY SENSOR CONTROLS

Added to the list of areas requiring Occupancy control are the following:

1. Computer/Data Center areas
2. Medical Supply Rooms and Telemedicine Rooms in health care facilities
3. Laundry

C405.2.2 – TIME-SWITCH CONTROLS

Shops and Labs removed from exempt list

Where no schedules are available, lights must be turned off at least 12 hours per day

C405.2.3 – DIMMING CONTROLS (FORMERLY LIGHT REDUCTION CONTROL)

Dimming controls (100%-10%) replace light reduction controls and specify applications where required including:

1. Classrooms/Lecture/Training
2. Conference/MP/Meeting
3. Dining
4. Laboratory
5. Lobby
6. Lounge/Break
7. Offices
8. Gym/Fitness
9. Library Reading
10. Imaging/Exam/Nursery/Nurses Station
11. Spaces without Occupancy Sensor

Not required where controls have a high-end trim

C405.2.4 – DAYLIGHT RESPONSIVE CONTROLS

Wattage reduced from 150W to 75W in primary and secondary zones

Not required in offices less than 250sf

C405.2.5 – SPECIFIC APPLICATION CONTROLS

No changes

C405.2.6 – MANUAL CONTROLS

No changes

C405.2.7 – EXTERIOR LIGHTING CONTROLS

Parking area fixtures requiring sensors reduced from 78w to 40w

C405.2.8 – RESERVED (FORMERLY PARKING GARAGE CONTROL)

Demand response functionality introduced. Does not say when or where required.

Reduce load by 20% or more

C405.2.9 – INTERIOR PARKING AREA CONTROL

No changes-just moved to new section

C405.2.10 – SLEEPING UNIT & DWELLING UNIT & SWITCHED RECEPTACLE CONTROL

Added the following requirements:

1. Two controlled receptacles per room except for bathrooms, kitchens, foyers, hallways and closets
- Added dedicated section C405.9 for Data Centers & Computer Rooms-no control requirements
 Energy Monitoring building size reduced from 25,000sf to 10,000sf.
 Must be able to provide total peak demand for building including time and day peak happens.
 A graphical display must be available

APPLICATION TYPE

TYPE OF SOLUTION (WIRED OR WIRELESS)

PRODUCT LAYOUT AND HOW THEY'RE CONNECTED

CLASSROOM WITH WINDOWS AND DAYLIGHTING ZONE - WIRED

CLASSROOM WITH WINDOWS AND DAYLIGHTING ZONE - WIRELESS

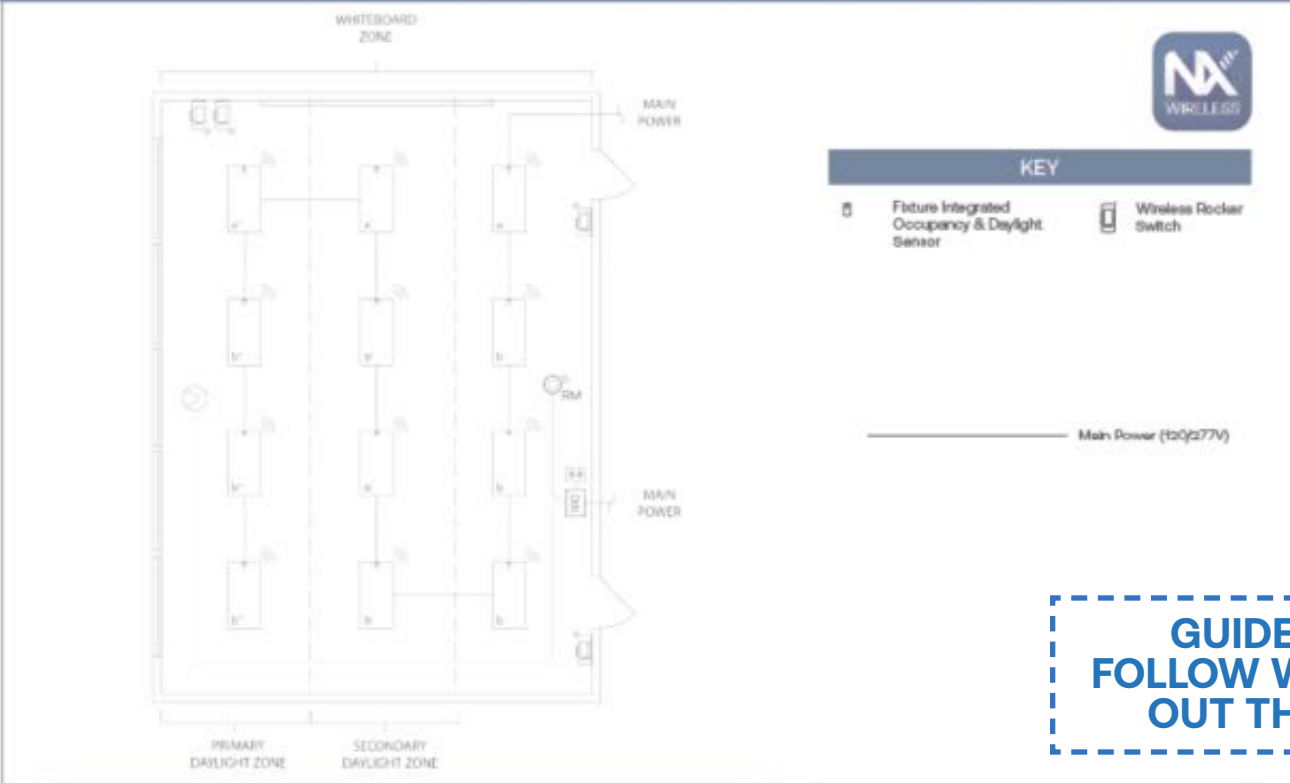
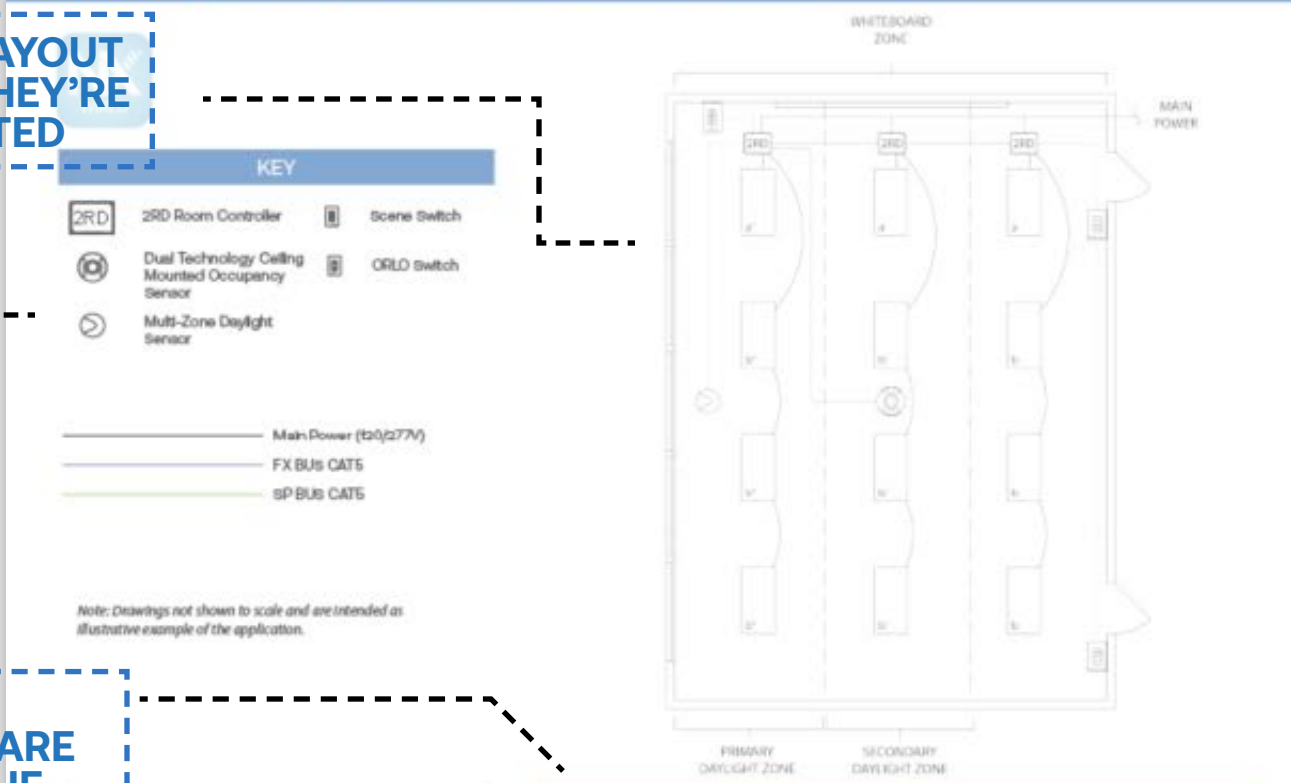

WHAT PRODUCTS ARE USED IN THE SPACE

BEST PRACTICE LAYOUT

- For optimal performance, the daylight sensor should be mounted near the window aperture and aligned to the middle of the opening for accurate measurement.
- ORLO switch stations should be located near each entrance to the space, and scene control switch should be located near the front of the classroom at teacher station for convenient adjustment of lighting levels during instruction.
- Ensure proper placement of occupancy sensors in space, keeping clear of any obstructions.
- Space can be networked back to an Area Controller for BMS integration or networked Automated Demand Response with only a few additional components, please see networking page for additional details.

BILL OF MATERIALS

QTY.	Catalog #	Description
3	NXRFX2-2RD-UNV	Room Controller with 2 Relays & 0-10V Dimming Outputs
1	NXSMDT-OMNI	Dual Technology Ceiling Mounted Occupancy Sensor
1	NXDS	Multi-Zone Daylight Sensor
1	NXSW2-SS	Scene Switch Specialty Switch
2	NXSW2-ORLO	On/Raise/Lower/Off Specialty Switch

- TYPICAL SEQUENCE OF OPERATIONS**
- 0-10V Dimming
 - 2 Manual control groups - front of class and general lighting
 - Auto ON <50% upon occupancy, or manual ON
 - Auto OFF after period of vacancy ≤ 20min
 - Manual On/Off/Raise/Lower control of fixtures
 - Plug load auto ON based on occupancy, and auto OFF after period of vacancy ≤20min or by scheduled OFF
 - Scene switch at teacher station for recall of presets and manual Raise/Lower control
 - Daylight Responsive Control required if there is more than 150w of lighting in the primary daylight zone or 300w in the primary and secondary daylight zones

GUIDELINES TO FOLLOW WHEN LAYING OUT THE SYSTEM

BEST PRACTICE LAYOUT

- Fixture integrated NX sensors can be used for both occupancy sensing and daylight harvesting when required.
- Switch stations should be located near each entrance to space and teacher's station for convenient access.
- Space can be networked back to an Area Controller for BMS integration or networked Automated Demand Response with only a few additional components, please see networking page for additional details.

BILL OF MATERIALS

QTY.	Catalog #	Description
4	NXSW-WRS-WH	Battery-Operated Wireless Rocker Switch
12	NXWSM*	NX Enabled Current Fixture with Integral Wireless Occupancy/Daylight Sensor

* See Integrated Control Options for Indoor Luminaires Ordering Logic and Description on pg. 54 for additional details.

- TYPICAL SEQUENCE OF OPERATIONS**
- 0-10V Dimming
 - Auto ON to 50-70% upon occupancy, or manual ON
 - Auto OFF after period of vacancy ≤ 20min
 - Manual On/Off/Raise/Lower control of each group of fixtures
 - Integral daylight sensor in fixtures for daylight harvesting capability where required (Exceptions: spaces with <24ft² of glazing or if lighting load is <120W combined in skylit and primary sidelit zones)

HOW THE SPACE FUNCTIONS

ENCLOSED OFFICE OR OPEN OFFICE <300ft² - WIRED

ENCLOSED OFFICE OR OPEN OFFICE <300ft² - WIRELESS



KEY

- 1RD Room Controller
- Dual Technology Wall Switch Occupancy Sensor
- Controlled Receptacle

- Main Power (120/277V)
- FX BUS CAT5

Note: Drawings not shown to scale and are intended as illustrative example of the application.

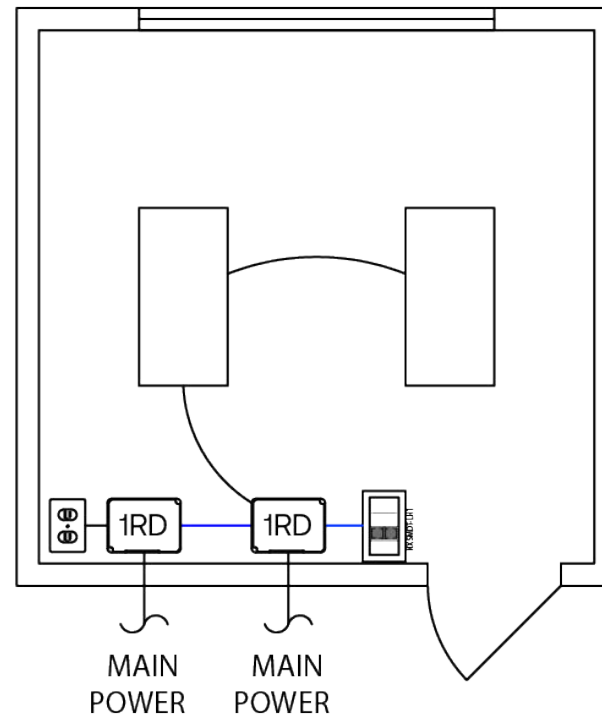

KEY

- 1RD Room Controller
- Radio Module
- Controlled Receptacle
- Wireless Rocker Switch
- Fixture Integrated Occupancy & Daylight Sensor

- Main Power (120/277V)
- FX BUS CAT5

Note: Drawings not shown to scale and are intended as illustrative example of the application.

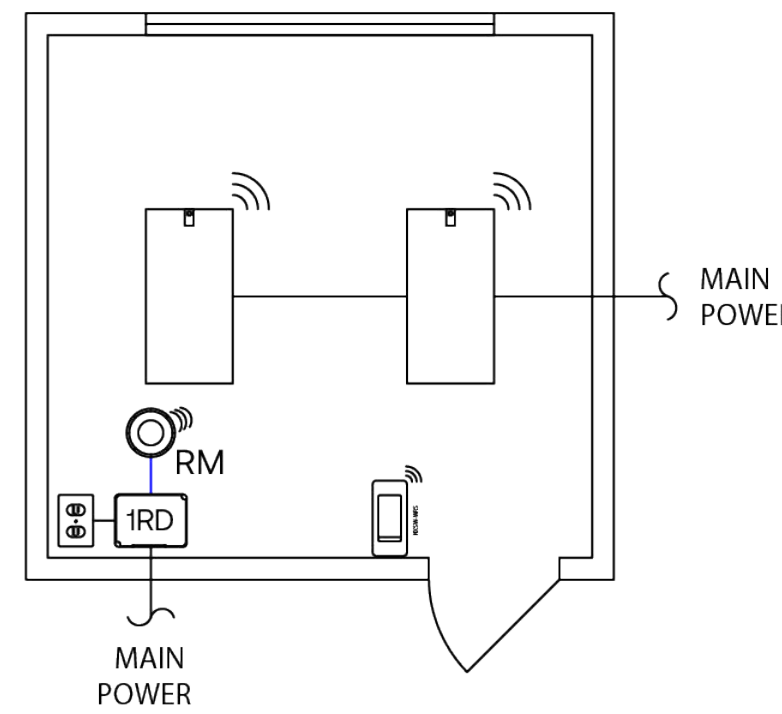

BEST PRACTICE LAYOUT

- NX LightHAWK can be used for occupancy sensing, daylight harvesting, as well as manual on/raise/lower/off control of lighting load in space
- Space can be networked back to an Area Controller for BMS integration or networked Automated Demand Response with only a few additional components, please see networking page for additional details

BILL OF MATERIALS

QTY.	Catalog #	Description
1	NXSMDT-LH1	Dual Technology Wall Switch Occupancy Sensor
2	NXRCFX2-1RD-UNV	Room Controller with 1 Relay & 0-10V Dimming Output

TYPICAL SEQUENCE OF OPERATIONS

- 0-10V Dimmable fixtures
- Lighting Manual ON/Auto OFF after period of vacancy ≤ 20 min
- Manual On/Off/Raise/Lower control of fixtures
- Plug load auto ON based on occupancy, and auto OFF after period of vacancy ≤ 20min or scheduled to turn off based on time clock
- Daylight Responsive Control required if there is more than 150w of lighting in the primary daylight zone or 300w in the primary and secondary daylight zones

BILL OF MATERIALS

QTY.	Catalog #	Description
1	NXSW2-WORLO-WH	NX Wireless AC Powered Specialty Switch, On/Raise/Lower/Off
1	NXRCFX2-1RD-UNV	Room Controller with 1 Relay & 0-10V Dimming Output
1	NXRM2-H	Radio Module
2	NXWSM*	NX Enabled Current Fixture with Integral Wireless Occupancy/Daylight Sensor

* See Integrated Control Options for Indoor Luminaires Ordering Logic and Description on pg. 50 for additional details

TYPICAL SEQUENCE OF OPERATIONS

- 0-10V Dimmable fixtures
- Lighting Manual ON/Auto OFF after period of vacancy ≤ 20 min
- Manual On/Off/Raise/Lower control of fixtures
- Plug load auto ON based on occupancy, and auto OFF after period of vacancy ≤ 20min or scheduled to turn off based on time clock
- Integral daylight sensor in fixtures for daylight harvesting where required (more than 75w of lighting in the primary daylight zone or 150w in the primary and secondary daylight zones)

BEST PRACTICE LAYOUT

- Fixture integrated NX sensors can be used for both occupancy sensing and daylight harvesting when required
- For indoor spaces, place radios within 100' line of sight of at least two other wireless devices
- Space can be networked back to an Area Controller for BMS integration or networked Automated Demand Response with only a few additional components, please see networking page for additional details

OPEN OFFICE >300ft² WITH WINDOWS AND DAYLIGHTING ZONE - WIRED

OPEN OFFICE >300ft² WITH WINDOWS AND DAYLIGHTING ZONE - WIRELESS



KEY

- 1RD Room Controller
- ORLO Switch
- 2RD Room Controller
- Controlled Receptacle
- UL924 Room Controller
- Dual Technology Ceiling Mounted Occupancy Sensor
- Multi-Zone Daylight Sensor
- Main Power (120/277V)
- FX BUS CAT5
- SP BUS CAT5

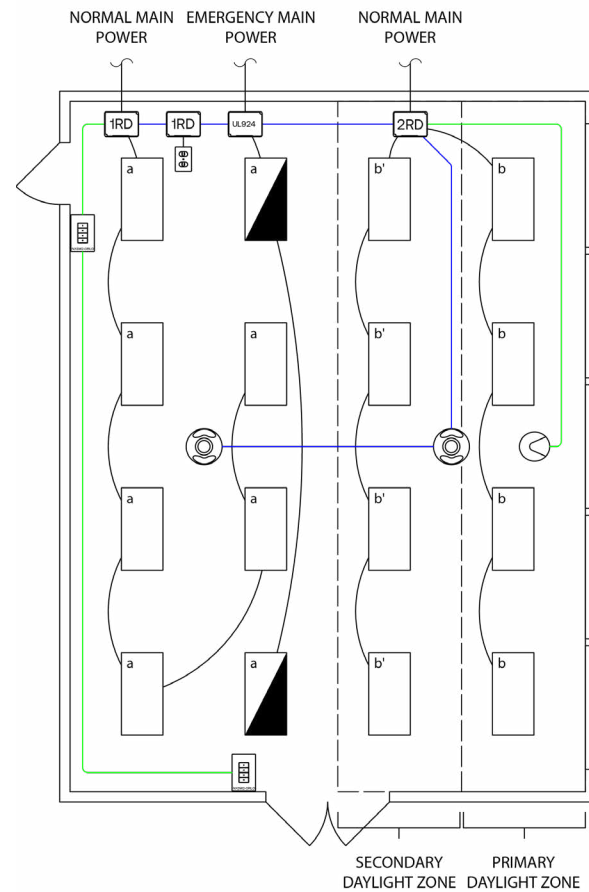

Note: Drawings not shown to scale and are intended as illustrative example of the application.

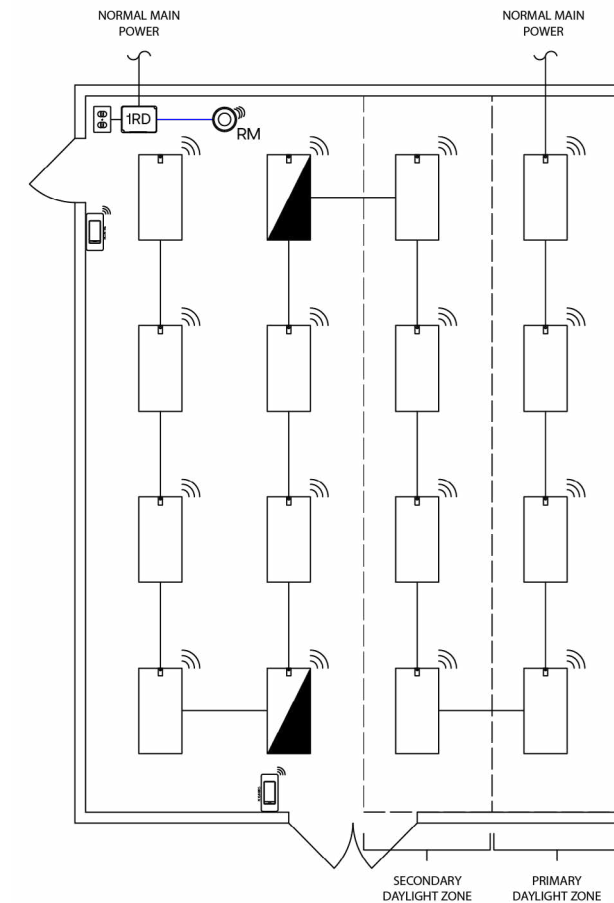

Wiring shown assumes emergency fixtures ordered with integral battery backup. Please see fixture spec sheet for details on ordering options.

KEY

- 1RD Room Controller
- Radio Module
- Wireless Rocker Switch
- Fixture Integrated Occupancy & Daylight Sensor
- Controlled Receptacle
- Main Power (120/277V)
- FX BUS CAT5

Note: Drawings not shown to scale and are intended as illustrative example of the application.

BEST PRACTICE LAYOUT

- For optimal performance, the daylight sensor should be mounted near the window aperture and aligned to the middle of the opening for accurate measurement
- Switch stations should be located near each entrance to the space
- Each occupancy control zone shall not exceed 600 ft²
- Ensure proper placement of occupancy sensors in space, keeping clear of any obstructions
- Space can be networked back to an Area Controller for BMS integration or networked Automated Demand Response with only a few additional components, please see networking page for additional details

BILL OF MATERIALS

QTY.	Catalog #	Description
2	NXRFX2-1RD-UNV	Room Controller with 1 Relay & 0-10V Dimming Output
2	NXSW2-ORLO	On/Raise/Lower/Off Specialty Switch
1	NXRFX2-2RD-UNV	Room Controller with 2 Relays & 0-10V Dimming Outputs
2	NXSMDT-OMNI	Dual Technology Ceiling Mounted Occupancy Sensor
1	NXDS	Multi-Zone Daylight Sensor
1	NXRC-UL924-UNV	Emergency Room Controller with 1 Relay & (2) 0-10V Dimming Outputs

TYPICAL SEQUENCE OF OPERATIONS

- 0-10V Dimmable fixtures
- Auto ON upon occupancy for each occupancy control zone not exceeding 600ft²
- Auto OFF after period of vacancy ≤ 20min for each occupancy zone
- Manual On/Off/Raise/Lower control of fixtures
- Plug load auto ON based on occupancy, and auto OFF after period of vacancy ≤ 20min or scheduled to turn off based on time clock
- Daylight Responsive Control required if there is more than 150w of lighting in the primary daylight zone or 300w in the primary and secondary daylight zones

BILL OF MATERIALS

QTY.	Catalog #	Description
1	NXRFX2-1RD-UNV	Room Controller with 1 Relay & 0-10V Dimming Output
1	NXRM2-H	Radio Module
2	NXSW2-WORLO-WH	NX Wireless AC Powered Specialty Switch, On/Raise/Lower/Off
16	NXWSM*	NX Enabled Current Fixture with Integral Wireless Occupancy/Daylight Sensor

*See Integrated Control Options for Indoor Luminaires Ordering Logic and Description on pg. 50 for additional details

TYPICAL SEQUENCE OF OPERATIONS

- 0-10V Dimmable fixtures
- Auto ON upon occupancy for each occupancy control zone not exceeding 600ft²
- Auto OFF after period of vacancy ≤ 20min for each occupancy zone
- Manual On/Off/Raise/Lower control of fixtures
- Plug load auto ON based on occupancy, auto OFF after period of vacancy ≤ 20min
- Fixture Integrated Daylight Responsive Control required if there is more than 150w of lighting in the primary daylight zone or 300w in the primary and secondary daylight zones

BEST PRACTICE LAYOUT

- Fixture integrated NX sensors can be used for both occupancy sensing and daylight harvesting when required
- For indoor spaces, place radios within 100' line of sight of at least two other wireless devices
- Switch stations should be located near each entrance to the space
- Each occupancy control zone shall not exceed 600 ft²
- Space can be networked back to an Area Controller for BMS integration or networked Automated Demand Response with only a few additional components, please see networking page for additional details

CONFERENCE ROOM - WIRED

CONFERENCE ROOM - WIRELESS



KEY

- 2RD Room Controller
- 1RD Room Controller
- Multi-Zone Daylight Sensor
- Controlled Receptacle
- Scene Switch
- Dual Technology Ceiling Mounted Occupancy Sensor
- Main Power (120/277V)
- FX BUS CAT5
- SP BUS CAT5

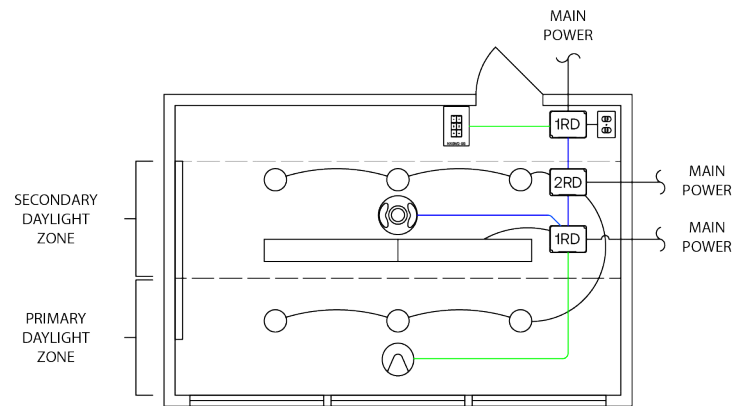

Note: Drawings not shown to scale and are intended as illustrative example of the application.

KEY

- Multi-Zone Daylight Sensor
- 1RD Room Controller
- Wireless Rocker Switch
- Controlled Receptacle
- Radio Module
- Fixture Integrated Occupancy & Daylight Sensor
- Main Power (120/277V)
- FX BUS CAT5
- SP BUS CAT5

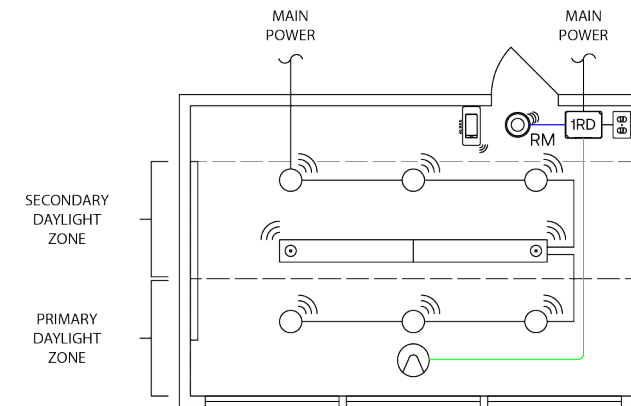

Note: Drawings not shown to scale and are intended as illustrative example of the application.

BILL OF MATERIALS		
QTY.	Catalog #	Description
2	NXRCFX2-1RD-UNV	Room Controller with 1 Relay & 0-10V Dimming Output
1	NXSW2-SS	Scene Switch Specialty Switch
1	NXRCFX2-2RD-UNV	Room Controller with 2 Relays & 0-10V Dimming Outputs
1	NXSMDT-OMNI	Dual Technology Ceiling Mounted Occupancy Sensor
1	NXDS	Multi-Zone Daylight Sensor

TYPICAL SEQUENCE OF OPERATIONS	
<ul style="list-style-type: none"> 0-10V Dimmable fixtures Auto ON <50% upon occupancy, or manual ON Auto OFF after period of vacancy ≤20min Scene switch for recalling programmed presets and manual Raise/Lower of activated scene 	<ul style="list-style-type: none"> Plug load auto ON based on occupancy, or OFF based on time clock Ceiling mounted daylight sensor for multi-zone daylight harvesting where required (Exceptions: in spaces with less than 75w of lighting in the primary daylight zone or 150w in the primary and secondary daylight zone)

BILL OF MATERIALS		
QTY.	Catalog #	Description
1	NXRCFX2-1RD-UNV	Room Controller with 1 Relay & 0-10V Dimming Output
1	NXRM2-H	Radio Module
1	NXSW2-WORLO-WH	NX Wireless AC Powered Specialty Switch, On/Raise/Lower/Off
1	NXDS	Multi-Zone Daylight Sensor
2	NXWRM*	NX Enabled Current Fixture with Integral Wireless Occupancy/Daylight Sensor

* See Integrated Control Options for Indoor Luminaires Ordering Logic and Description on pg. 50 for additional details.

TYPICAL SEQUENCE OF OPERATIONS	
<ul style="list-style-type: none"> 0-10V Dimmable fixtures Auto ON to 50-70% upon occupancy, or manual ON Auto OFF after period of vacancy ≤20min Scene switch for recalling programmed presets and manual Raise/Lower of activated scene 	<ul style="list-style-type: none"> Plug load auto ON based on occupancy, and auto OFF after period of vacancy ≤20min Ceiling mounted daylight sensor for multi-zone daylight harvesting where required (more than 75w of lighting in the primary daylight zone or 150w in the primary and secondary daylight zones)

BEST PRACTICE LAYOUT

- For optimal performance, the daylight sensor should be mounted near the window aperture and aligned to the middle of the opening for accurate measurement
- Switch stations should be located near each entrance to the space
- Ensure proper placement of occupancy sensors in space, keeping clear of any obstructions
- Space can be networked back to an Area Controller for BMS integration or networked Automated Demand Response with only a few additional components, please see networking page for additional details

BEST PRACTICE LAYOUT

- For optimal performance, the daylight sensor should be mounted near the window aperture and aligned to the middle of the opening for accurate measurement
- Switch stations should be located near each entrance to the space
- Space can be networked back to an Area Controller for BMS integration or networked Automated Demand Response with only a few additional components, please see networking page for additional details
- For indoor spaces, place radios within 100' line of sight of at least two other wireless devices

CLASSROOM WITH WINDOWS AND DAYLIGHTING ZONE - WIRED

CLASSROOM WITH WINDOWS AND DAYLIGHTING ZONE - WIRELESS



KEY

- 2RD Room Controller
- Scene Switch
- Dual Technology Ceiling Mounted Occupancy Sensor
- ORLO Switch
- Multi-Zone Daylight Sensor
- Main Power (120/277V)
- FX BUS CAT5
- SP BUS CAT5

Note: Drawings not shown to scale and are intended as illustrative example of the application.

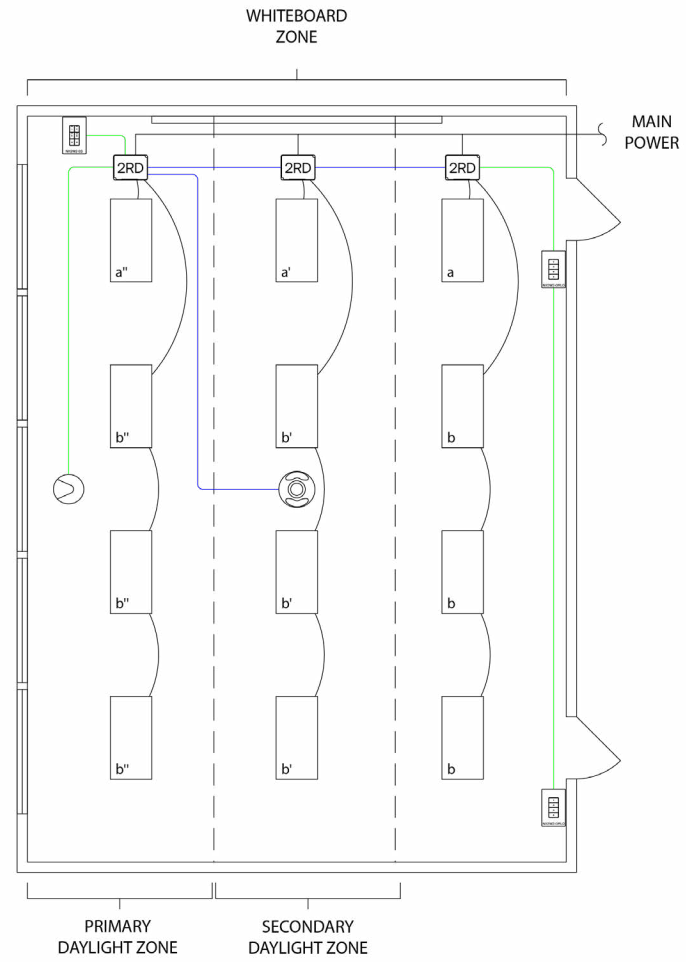

BEST PRACTICE LAYOUT

- For optimal performance, the daylight sensor should be mounted near the window aperture and aligned to the middle of the opening for accurate measurement
- ORLO switch stations should be located near each entrance to the space, and scene control switch should be located near the front of the classroom at teacher station for convenient adjustment of lighting levels during instruction
- Ensure proper placement of occupancy sensors in space, keeping clear of any obstructions
- Space can be networked back to an Area Controller for BMS integration or networked Automated Demand Response with only a few additional components, please see networking page for additional details

BILL OF MATERIALS

QTY.	Catalog #	Description
3	NXRCFX2-2RD-UNV	Room Controller with 2 Relays & 0-10V Dimming Outputs
1	NXSMdT-OMNI	Dual Technology Ceiling Mounted Occupancy Sensor
1	NXDS	Multi-Zone Daylight Sensor
1	NXSW2-SS	Scene Switch Specialty Switch
2	NXSW2-ORLO	On/Raise/Lower/Off Specialty Switch

TYPICAL SEQUENCE OF OPERATIONS

- 0-10V Dimming
- 2 Manual control groups—front of class and general lighting
- Auto ON <50% upon occupancy, or manual ON
- Auto OFF after period of vacancy ≤20min
- Manual On/Off/Raise/Lower control of fixtures
- Scene switch at teacher station for recall of presets and manual Raise/Lower control
- Daylight Responsive Control required if there is more than 150w of lighting in the primary daylight zone or 300w in the primary and secondary daylight zones
- Plug load auto ON based on occupancy, and auto off period of vacancy ≤20min or by scheduled OFF

BILL OF MATERIALS

QTY.	Catalog#	Description
4	NXSW2-WORLO-WH	NX Wireless AC Powered Specialty Switch, On/Raise/Lower/Off
12	NXWSM*	NX Enabled Current Fixture with Integral Wireless Occupancy/Daylight Sensor
1	NXRM2-H	Radio Module
1	NXDS	Multi-Zone Daylight Sensor
1	NXRCFX2-1RD-UNV	Room Controller with 1 Relay & 0-10V Dimming Output

* See Integrated Control Options for Indoor Luminaires Ordering Logic and Description on pg. 50 for additional details.

TYPICAL SEQUENCE OF OPERATIONS

- 0-10V Dimming
- Auto ON to 50-70% upon occupancy, or manual ON
- Auto OFF after period of vacancy ≤ 20min
- Manual On/Off/Raise/Lower control of each group of fixtures
- Plug load auto ON based on occupancy, and auto OFF after period of vacancy ≤20min or by scheduled OFF
- Integral Daylight Responsive Control required if there is more than 150w of lighting in the primary daylight zone or 300w in the primary and secondary daylight zones

KEY

- Fixture Integrated Occupancy & Daylight Sensor
- Wireless Rocker Switch
- Multi-Zone Daylight Sensor
- Radio Module
- 1RD Room Controller
- Controlled Receptacle*
- Main Power (120/277V)

Note: Drawings not shown to scale and are intended as illustrative example of the application.

* Controlled Receptacle shown as an example to be used when desired or required by local code.

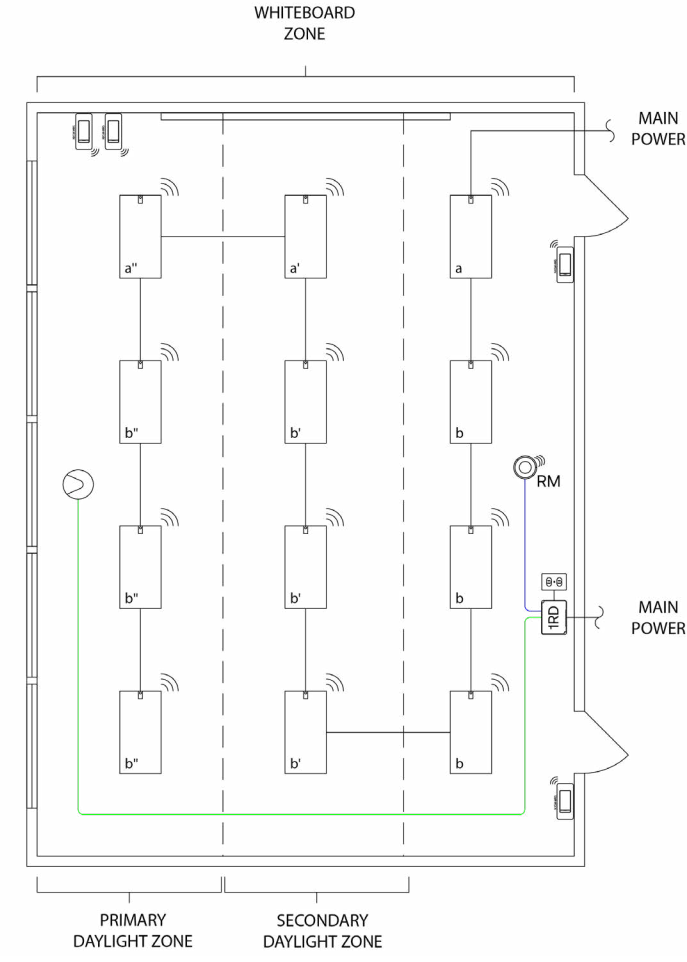

BEST PRACTICE LAYOUT

- Fixture integrated NX sensors can be used for both occupancy sensing and daylight harvesting when required
- Switch stations should be located near each entrance to space and teacher's station for convenient access
- Space can be networked back to an Area Controller for BMS integration or networked Automated Demand Response with only a few additional components, please see networking page for additional details

LOBBY - WIRED

LOBBY - WIRELESS



KEY

- Multi-Zone Daylight Sensor
- 1RD Room Controller
- 2RD Room Controller
- Dual Technology Ceiling Mounted Occupancy Sensor
- ORLO Switch
- Controlled Receptacle
- Main Power (120/277V)
- FX BUS CAT5
- SP BUS CAT5

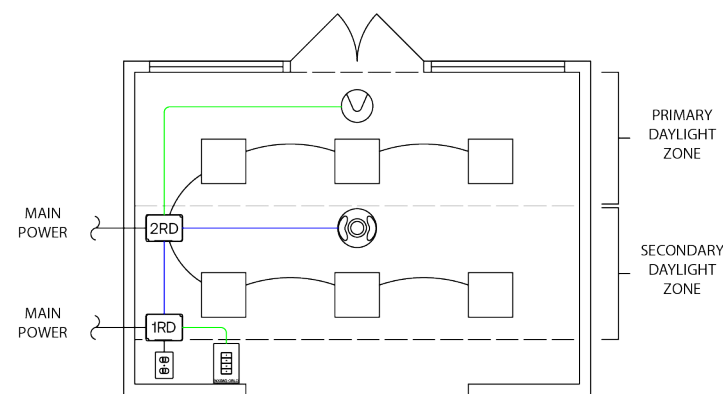

Note: Drawings not shown to scale and are intended as illustrative example of the application.

KEY

- 1RD Room Controller
- Radio Module
- Controlled Receptacle
- Fixture Integrated Occupancy & Daylight Sensor
- Wireless Rocker Switch
- Main Power (120/277V)
- FX BUS CAT5

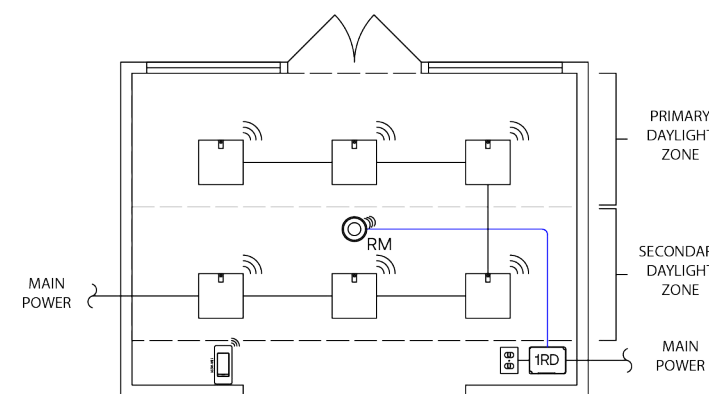

Note: Drawings not shown to scale and are intended as illustrative example of the application.

BEST PRACTICE LAYOUT

- For optimal performance, the daylight sensor should be mounted near the window aperture and aligned to the middle of the opening for accurate measurement
- Switch stations should be located near each entrance to the space
- Ensure proper placement of occupancy sensors in space, keeping clear of any obstructions
- Space can be networked back to an Area Controller for BMS integration or networked Automated Demand Response with only a few additional components, please see networking page for additional details

BILL OF MATERIALS

QTY.	Catalog #	Description
1	NXRCFX2-1RD-UNV	Room Controller with 1 Relay & 0-10V Dimming Output
1	NXRCFX2-2RD-UNV	Room Controller with 2 Relays & 0-10V Dimming Outputs
1	NXSMDT-OMNI	Dual Technology Ceiling Mounted Occupancy Sensor
1	NXSW2-ORLO	On/Raise/Lower/Off Specialty Switch
1	NXDS	Multi-Zone Daylight Sensor

TYPICAL SEQUENCE OF OPERATIONS

- 0-10V Dimmable fixtures
- Auto ON to Full
- Auto OFF after period of vacancy ≤20min
- Manual On/Off/Raise/Lower control of fixtures
- Plug load auto ON based on occupancy, and auto OFF after period of vacancy ≤20min
- Daylight Responsive Control required if there is more than 150w of lighting in the primary daylight zone or 300w in the primary and secondary daylight zones

BILL OF MATERIALS

QTY.	Catalog #	Description
1	NXRCFX2-1RD-UNV	Room Controller with 1 Relay & 0-10V Dimming Output
1	NXRM2-H	Radio Module
1	NXSW2-WORLO-WH	NX Wireless AC Powered Specialty Switch, On/Raise/Lower/Off
6	NXWSM*	NX Enabled Current Fixture with Integral Wireless Occupancy/Daylight Sensor

* See Integrated Control Options for Indoor Luminaires Ordering Logic and Description on pg. 50 for additional details.

TYPICAL SEQUENCE OF OPERATIONS

- 0-10V Dimmable fixtures
- Auto ON to Full
- Auto OFF after period of vacancy ≤20min
- Manual On/Off/Raise/Lower control of fixtures
- Plug load auto ON based on occupancy, and auto OFF after period of vacancy ≤20min
- Integral Daylight Responsive Control required if there is more than 150w of lighting in the primary daylight zone or 300w in the primary and secondary daylight

BEST PRACTICE LAYOUT

- Fixture integrated NX sensors can be used for both occupancy sensing and daylight harvesting when required
- For indoor spaces, place radios within 100' line of sight of at least two other wireless devices
- Switch stations should be located near each entrance to the space
- Space can be networked back to an Area Controller for BMS integration or networked Automated Demand Response with only a few additional components, please see networking page for additional details

ELEVATOR LOBBY - WIRED

ELEVATOR LOBBY - WIRELESS



KEY

KEY

- 1RD 1RD Room Controller
- Dual Technology Ceiling Mounted Occupancy Sensor

- Fixture Integrated Occupancy & Daylight Sensor

- Main Power (120/277V)
- FX BUS CAT5

- Main Power (120/277V)

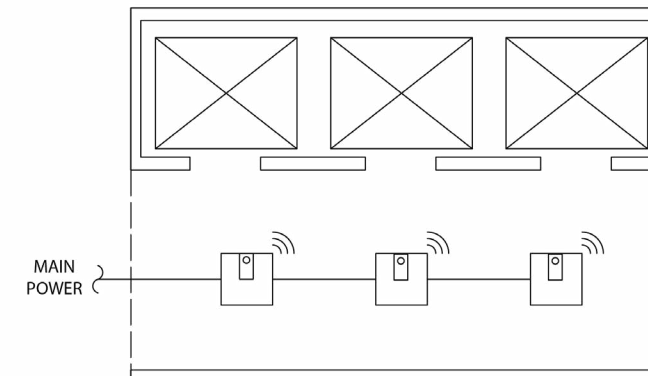
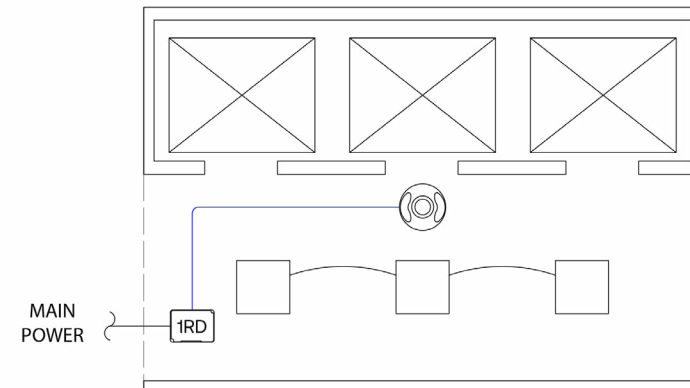

Note: Drawings not shown to scale and are intended as illustrative example of the application.

Note: Drawings not shown to scale and are intended as illustrative example of the application.

BEST PRACTICE LAYOUT

- For optimal performance, the daylight sensor should be mounted near the window aperture and aligned to the middle of the opening for accurate measurement
- Ensure proper placement of occupancy sensors in space, keeping clear of any obstructions
- Space can be networked back to an Area Controller for BMS integration or networked Automated Demand Response with only a few additional components, please see networking page for additional details

BEST PRACTICE LAYOUT

- Fixture integrated NX sensors can be used for both occupancy sensing and daylight harvesting when required
- For indoor spaces, place radios within 100' line of sight of at least two other wireless devices
- Space can be networked back to an Area Controller for BMS integration or networked Automated Demand Response with only a few additional components, please see networking page for additional details

BILL OF MATERIALS

QTY.	Catalog #	Description
1	NXRCFX2-1RD-UNV	Room Controller with 1 Relay & 0-10V Dimming Output
1	NXSMDT-OMNI	Dual Technology Ceiling Mounted Occupancy Sensor

BILL OF MATERIALS

QTY.	Catalog #	Description
1	NXRCFX2-1RD-UNV	Room Controller with 1 Relay & 0-10V Dimming Output
1	NXRM2-H	Radio Module
6	NXWSM*	NX Enabled Current Fixture with Integral Wireless Occupancy/Daylight Sensor

* See Integrated Control Options for Indoor Luminaires Ordering Logic and Description on pg. 50 for additional details.

TYPICAL SEQUENCE OF OPERATIONS

- 0-10V Dimmable fixtures
- Auto ON to Full
- Reduce lighting to 50% power after a period of vacancy ≤20 min
- Daylight Responsive Control required if there is more than 150w of lighting in the primary daylight zone or 300w in the primary and secondary daylight zones.

TYPICAL SEQUENCE OF OPERATIONS

- 0-10V Dimmable fixtures
- Auto ON to Full
- Reduce lighting to 50% power after a period of vacancy ≤20 min
- Integral Daylight Responsive Control required if there is more than 150w of lighting in the primary daylight zone or 300w in the primary and secondary daylight zones

CORRIDOR - WIRED

CORRIDOR - WIRELESS



KEY

- 1RD Room Controller
- UL924 Room Controller
- Dual Technology Ceiling Mounted Occupancy Sensor
- ORLO Switch

- Main Power (120/277V)
- FX BUS CAT5
- SP BUS CAT5

Note: Drawings not shown to scale and are intended as illustrative example of the application.

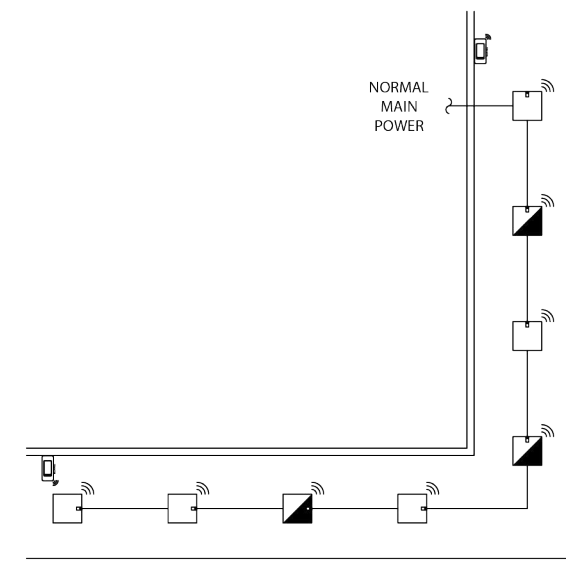
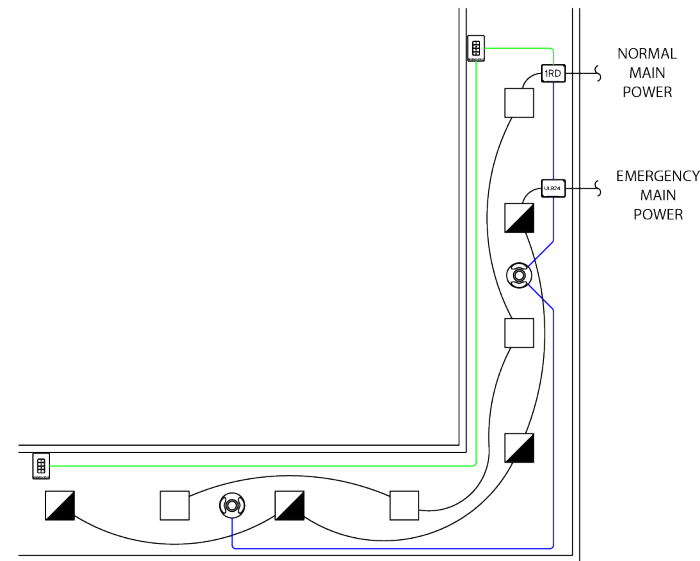

KEY

- Wireless Rocker Switch
- Fixture Integrated Occupancy & Daylight Sensor

- Main Power (120/277V)

Note: Drawings not shown to scale and are intended as illustrative example of the application.

Wiring shown assumes emergency fixtures ordered with integral battery backup. Please see fixture spec sheet for details on ordering options.

BEST PRACTICE LAYOUT

- Switch stations should be located near each entrance to the space
- Ensure proper placement of occupancy sensors throughout the corridor, keeping clear of any obstructions
- Space can be networked back to an Area Controller for BMS integration or networked Automated Demand Response with only a few additional components, please see networking page for additional details

BILL OF MATERIALS

QTY.	Catalog #	Description
1	NXRFCX2-1RD-UNV	Room Controller with 1 Relay & 0-10V Dimming Output
1	NXRC-UL924-UNV	UL924 Emergency Room Controller with 1 Relay & (2) 0-10V Dimming Outputs
2	NXSW2-ORLO	On/Raise/Lower/Off Specialty Switch
2	NXSMDT-OMNI	Dual Technology Ceiling Mounted Occupancy Sensor

TYPICAL SEQUENCE OF OPERATIONS

- 0-10V Dimmable fixtures
- Auto full ON upon occupancy
- Partial OFF to ≤50% after period of vacancy ≤ 20min
- Manual On/Off/Raise/Lower control of fixtures

BILL OF MATERIALS

QTY.	Catalog #	Description
2	NXSW2-WORLO-WH	NX Wireless AC Powered Specialty Switch, On/Raise/Lower/Off
8	NXWSM*	NX Enabled Current Fixture with Integral Wireless Occupancy/Daylight Sensor

* See Integrated Control Options for Indoor Luminaires Ordering Logic and Description on pg. 50 for additional details.

TYPICAL SEQUENCE OF OPERATIONS

- 0-10V Dimmable fixtures
- Auto full ON upon occupancy
- Partial OFF to ≤50% after period of vacancy ≤ 20min
- Manual On/Off/Raise/Lower control of fixtures

BEST PRACTICE LAYOUT

- Fixture integrated NX sensors can be used for both occupancy sensing and daylight harvesting when required
- Switch stations should be located near each entrance to the space
- Space can be networked back to an Area Controller for BMS integration or networked Automated Demand Response with only a few additional components, please see networking page for additional details

PUBLIC RESTROOM - WIRED

PRIVATE OR SINGLE RESTROOM - WIRED



KEY

- 1RD Room Controller
- UL924 Room Controller
- Key Switch
- Dual Technology Ceiling Mounted Occupancy Sensor
- Main Power (120/277V)
- FX BUS CAT5
- SP BUS CAT5

Note: Drawings not shown to scale and are intended as illustrative example of the application.

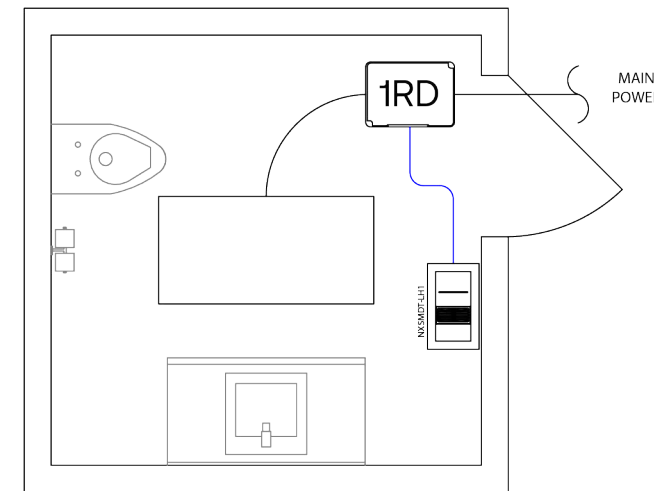
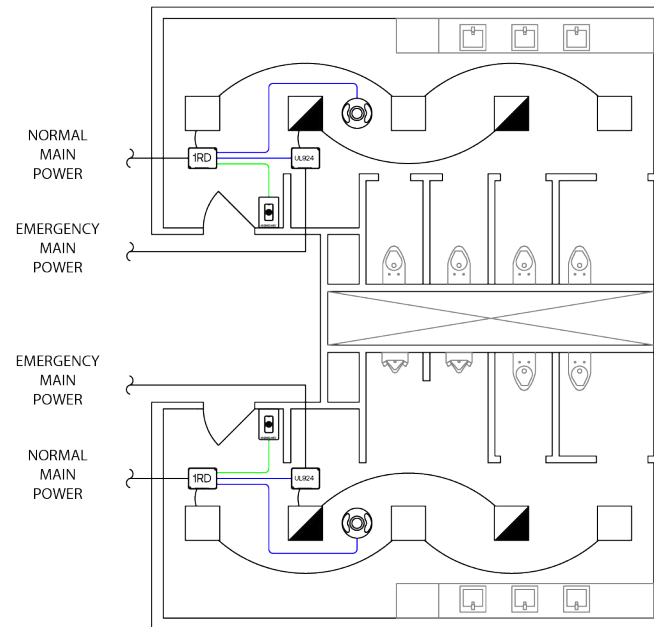

KEY

- 1RD Room Controller
- Dual Technology Wall Switch Occupancy Sensor
- Main Power (120/277V)
- FX BUS CAT5

Note: Drawings not shown to scale and are intended as illustrative example of the application.

BEST PRACTICE LAYOUT

- Switch stations should be located near each entrance to the space
- Ensure proper placement of occupancy sensors in space, keeping clear of any obstructions
- Space can be networked back to an Area Controller for BMS integration or networked Automated Demand Response with only a few additional components, please see networking page for additional details

BILL OF MATERIALS

QTY.	Catalog #	Description
2	NXRCFX2-1RD-UNV	Room Controller with 1 Relay & 0-10V Dimming Output
2	NXRC-UL924-UNV	UL924 Emergency Room Controller with 1 Relay & (2) 0-10V Dimming Outputs
2	NXSW2-KEY	Digital Key Switch
2	NXSMDT-OMNI	Dual Technology Ceiling Mounted Occupancy Sensor

TYPICAL SEQUENCE OF OPERATIONS

- 0-10V Dimmable fixtures
- Auto ON to Full
- Auto OFF after period of vacancy ≤20min

BILL OF MATERIALS

QTY.	Catalog #	Description
1	NXSMDT-LH1	Dual Technology Wall Switch Occupancy Sensor
1	NXRCFX2-1RD-UNV	Room Controller with 1 Relay & 0-10V Dimming Output

TYPICAL SEQUENCE OF OPERATIONS

- 0-10V Dimmable fixtures
- Auto ON to Full upon occupancy, or manual ON
- Auto OFF after period of vacancy ≤20min
- Manual On/Off/Raise/Lower control of fixtures

BEST PRACTICE LAYOUT

- NX LightHAWK can be used for occupancy sensing, daylight harvesting, as well as manual on/raise/lower/off control of lighting load in space
- Space can be networked back to an Area Controller for BMS integration or networked Automated Demand Response with only a few additional components, please see networking page for additional details

WAREHOUSE - WIRED

WAREHOUSE - WIRELESS



KEY

- 2RD Room Controller
- UL924 Room Controller
- 1RD Room Controller
- High Mount PIR Occupancy Sensor
- 8-Button Switch
- Main Power (120/277V)
- FX BUS CAT5
- SP BUS CAT5

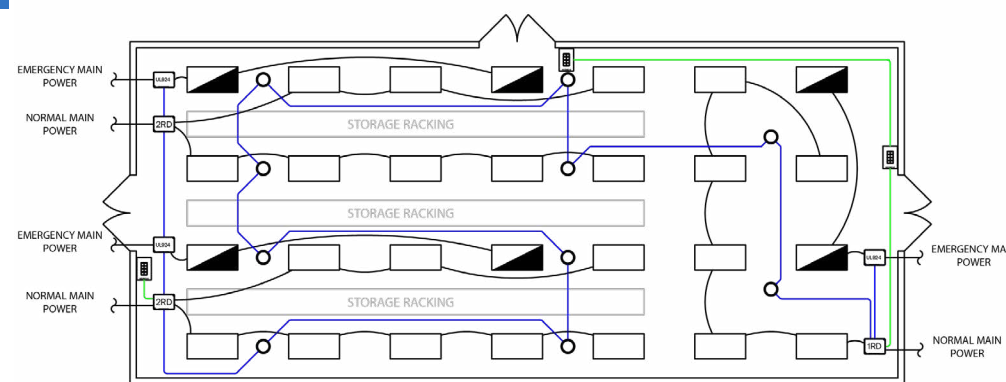

Note: Drawings not shown to scale and are intended as illustrative example of the application.

KEY

- Wireless Rocker Switch
- Fixture Integrated Occupancy & Daylight Sensor
- Main Power (120/277V)

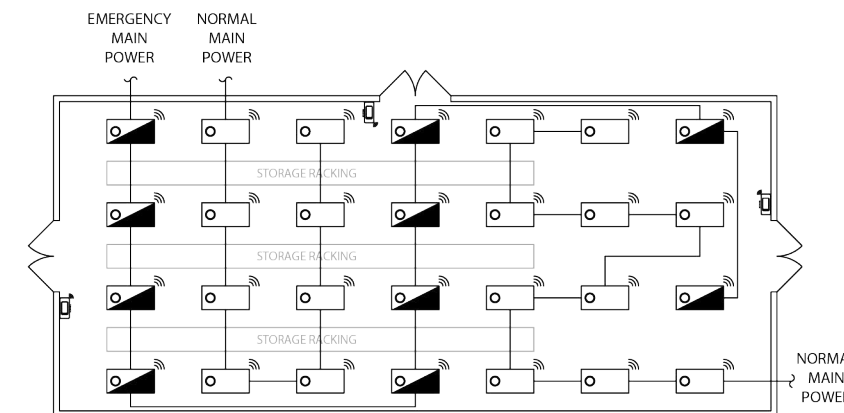

Note: Drawings not shown to scale and are intended as illustrative example of the application.

Wiring shown assumes emergency fixtures ordered with integral UL924 dimming bypass module. Please see fixture spec sheet for details on ordering options.

BILL OF MATERIALS

QTY.	Catalog #	Description
3	NXSW2-WORLO-WH	NX Wireless AC Powered Specialty Switch, On/Raise/Lower/Off
28	NXWHM*	NX Enabled Current Fixture with Integral Wireless Occupancy/Daylight Sensor

* See Integrated Control Options for Indoor Luminaires Ordering Logic and Description on pg. 50 for additional details.

TYPICAL SEQUENCE OF OPERATIONS

- 0-10V Dimmable fixtures
- Auto full ON upon occupancy
- Partial OFF to ≤50% after period of vacancy ≤ 20min
- Manual On/Off/Raise/Lower control of fixtures
- Full off by Occupancy Sensor “grace period” or time schedule

BEST PRACTICE LAYOUT

- Switch stations should be located near each entrance to the space
- Ensure proper placement of occupancy sensors in space, keeping clear of any obstructions
- Space can be networked back to an Area Controller for BMS integration or networked Automated Demand Response with only a few additional components, please see networking page for additional details

BILL OF MATERIALS

QTY.	Catalog #	Description
2	NXRCFX2-2RD-UNV	Room Controller with 2 Relays & 0-10V Dimming Outputs
5	NXRC-UL924-UNV	UL924 Emergency Room Controller with 1 Relay & (2) 0-10V Dimming Outputs
10	NXSMP2-HMO	High Mount PIR Occupancy Sensor
1	NXRCFX2-1RD-UNV	Room Controller with 1 Relay & 0-10V Dimming Output
3	NXSW2-8	8-Button Smart Switch

TYPICAL SEQUENCE OF OPERATIONS

- 0-10V Dimmable fixtures
- Auto full ON upon occupancy
- Partial OFF to ≤50% after period of vacancy ≤ 20min
- Full off by Occupancy Sensor “grace period” or time schedule
- Manual On/Off/Raise/Lower control of fixtures

BEST PRACTICE LAYOUT

- Fixture integrated NX sensors can be used for both occupancy sensing and daylight harvesting when required
- Switch stations should be located near each entrance to the space
- Space can be networked back to an Area Controller for BMS integration or networked Automated Demand Response with only a few additional components, please see networking page for additional details

GYMNASIUM - WIRED

GYMNASIUM - WIRELESS



KEY

- UL924 Room Controller
- 1RD Room Controller
- Keyswitch
- 8-Button Switch
- High Mount PIR Occupancy Sensor
- Main Power (120/277V)
- FX BUS CAT5
- SP BUS CAT5

Note: Drawings not shown to scale and are intended as illustrative example of the application.

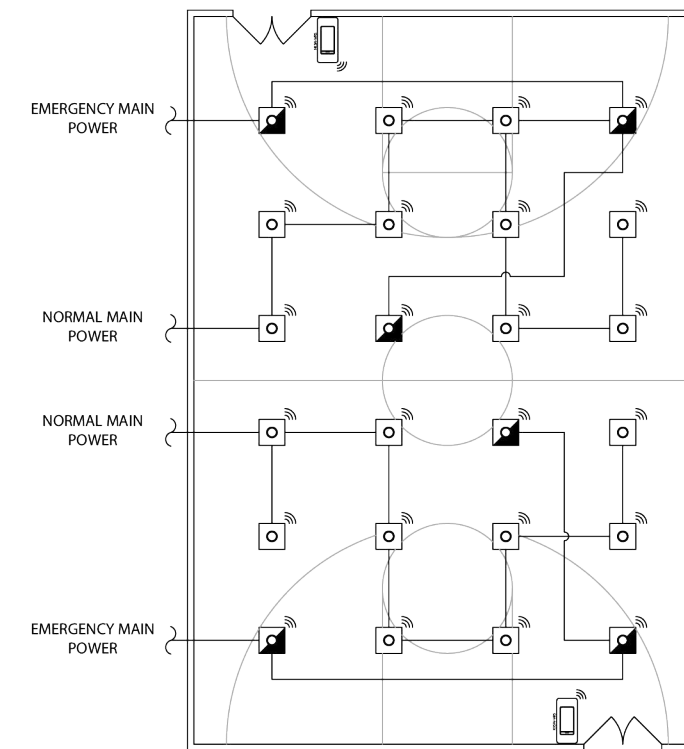
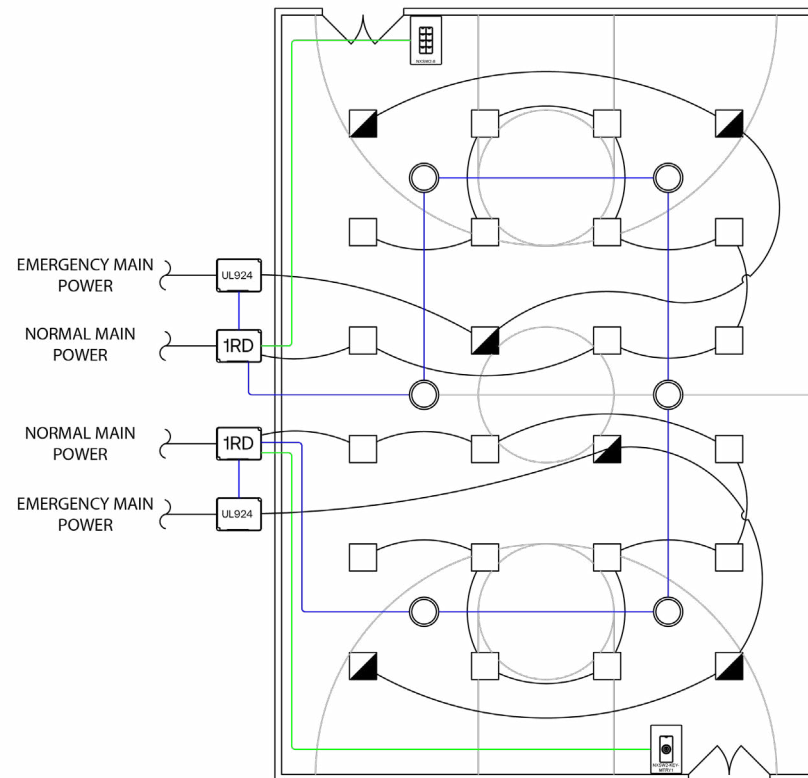

KEY

- Fixture Integrated Occupancy & Daylight Sensor
- Wireless Rocker Switch
- Main Power (120/277V)

Note: Drawings not shown to scale and are intended as illustrative example of the application.

Wiring shown assumes emergency fixtures ordered with integral UL924 dimming bypass module. Please see fixture spec sheet for details on ordering options.

BEST PRACTICE LAYOUT

- Switch stations should be located near each entrance to the space
- Ensure proper placement of occupancy sensors in space, keeping clear of any obstructions
- Space can be networked back to an Area Controller for BMS integration or networked Automated Demand Response with only a few additional components, please see networking page for additional details

BILL OF MATERIALS

QTY.	Catalog #	Description
2	NXRFX2-1RD-UNV	Room Controller with 1 Relay & 0-10V Dimming Output
1	NXSW2-8	8-Button Smart Switch
6	NXSMP2-HMO	High Mount PIR Occupancy & Daylight Sensor
2	NXRC-UL924-UNV	Emergency Room Controller with 1 Relay & (2) 0-10V Dimming Outputs
1	NXSW2-KEY-MNTD1-WH	Specialty key Switch

TYPICAL SEQUENCE OF OPERATIONS

- 0-10V Dimmable fixtures
- Auto ON to 50-70% upon schedule, or manual ON
- Auto OFF after period of vacancy ≤20min
- Manual ON/OFF/Raise/Lower control of each group of fixtures

BILL OF MATERIALS

QTY.	Catalog #	Description
2	NXSW2-WORLO-WH	NX Wireless AC Powered Specialty Switch, On/Raise/Lower/Off
1	NXWHM*	NX Enabled Current Fixture with Integral Wireless Occupancy/Daylight Sensor

* See Integrated Control Options for Indoor Luminaires Ordering Logic and Description on pg. 50 for additional details.

TYPICAL SEQUENCE OF OPERATIONS

- 0-10V Dimmable fixtures
- Auto ON to 50-70% upon occupancy, or manual ON
- Auto OFF after period of vacancy ≤20min
- Manual ON/OFF/Raise/Lower control of fixtures

BEST PRACTICE LAYOUT

- Fixture integrated NX sensors can be used for both occupancy sensing and daylight harvesting when required
- Switch stations should be located near each entrance to the space
- Space can be networked back to an Area Controller for BMS integration or networked Automated Demand Response with only a few additional components, please see networking page for additional details

INTERIOR LEVEL PARKING GARAGE - WIRELESS

SITE WITH PARKING LOT - WIRELESS



KEY

- ORLO Switch
- 1RD Room Controller
- Fixture Integrated Occupancy & Daylight Sensor
- Radio Module

— Main Power (120/277V)
 — FX BUS CAT5

Note: Drawings not shown to scale and are intended as illustrative example of the application.

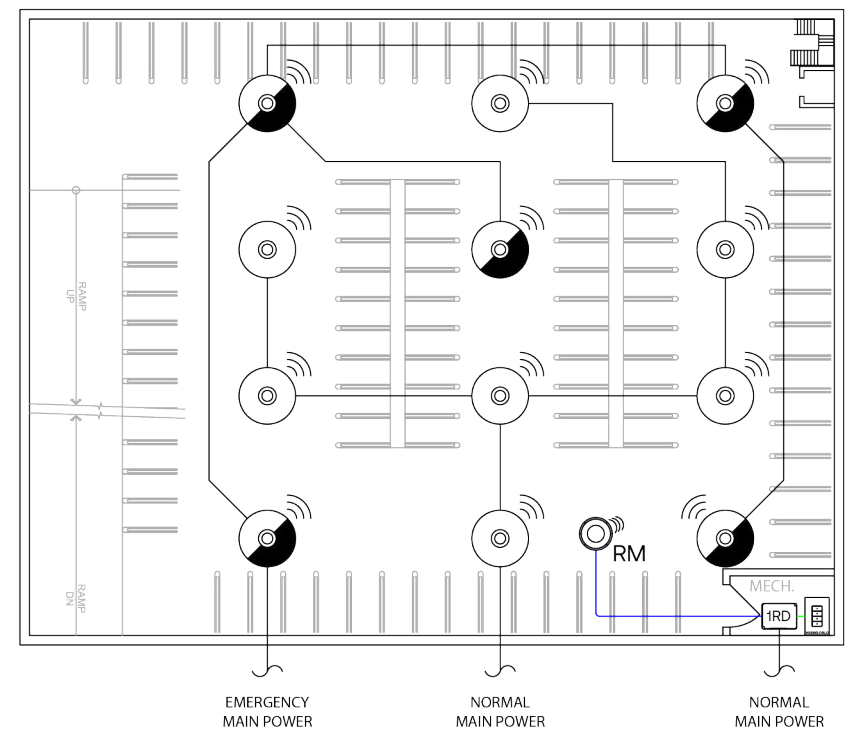

Wiring shown assumes emergency fixtures ordered with integral UL924 dimming bypass module. Please see fixture spec sheet for details on ordering options.

BILL OF MATERIALS

QTY.	Catalog #	Description
1	NXRFCX2-1RD-UNV	Room Controller with 1 Relay & 0-10V Dimming Output
1	NXRM2-H	Radio Module
1	NXSW2-WORLO-WH	NX Wireless AC Powered Specialty Switch, On/Raise/Lower/Off
12	NXWS12F	NX Enabled Current Fixture with Integral Wireless Occupancy/Daylight Sensor

* See Integrated Control Options for Indoor Luminaires Ordering Logic and Description on pg. 50 for additional details

TYPICAL SEQUENCE OF OPERATIONS

- 0-10V Dimmable fixtures
- Auto full ON upon occupancy
- Partial OFF to 70% or less after period of vacancy ≤ 20min
- Luminaires <20ft from open sides shall dim to <50% when sufficient daylight is present
- Manual ON/OFF/Raise/Lower control of fixtures
- Control zones shall have a lighting load of ≤ 500W per zone, not bigger than 3600ft²
- Eye adaption at entry: reduce output by 50% between Sunset and Sunrise.

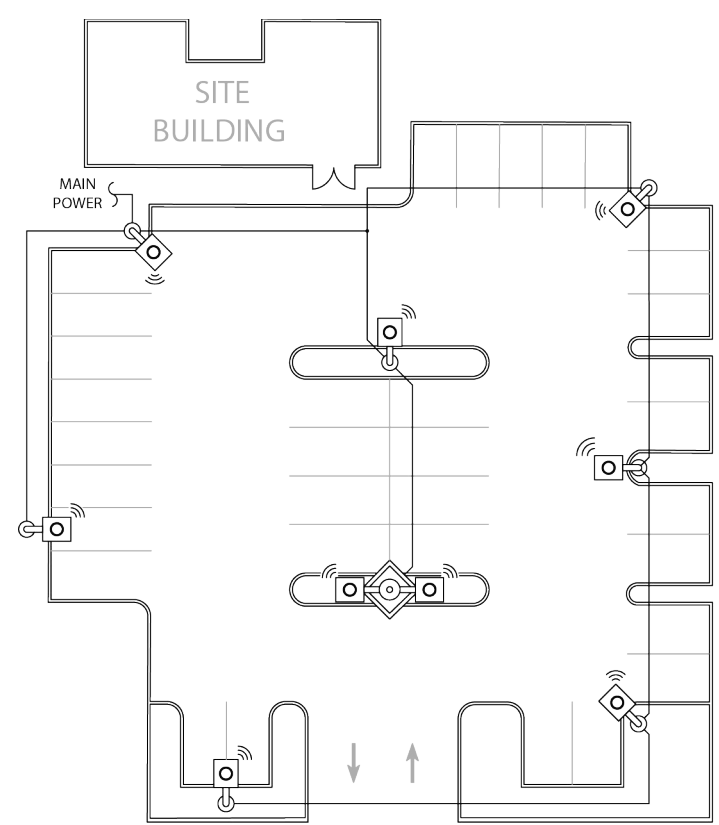

KEY

- Fixture Integrated Occupancy & Daylight Sensor

— Main Power (120/277V)

Note: Drawings not shown to scale and are intended as illustrative example of the application.

BILL OF MATERIALS

QTY.	Catalog #	Description
9	NXWS16F*	NX Enabled Current Fixture with Integral Wireless Occupancy/Daylight Sensor

* See Integrated Control Options for Indoor Luminaires Ordering Logic and Description on pg. 50 for additional details

TYPICAL SEQUENCE OF OPERATIONS

- 0-10V Dimmable fixtures
- Integral astronomic time clock enables occupancy sensor operation from dusk to dawn and ensure lights are OFF during the daytime
- Auto full ON upon occupancy during active sensor hours
- Partial OFF to 10-50% after period of vacancy ≤15min when sensors are active

BEST PRACTICE LAYOUT

- Fixture integrated NX sensors can be used for both occupancy sensing and daylight harvesting when required
- Switch stations should be inaccessible to unauthorized personnel
- Space can be networked back to an Area Controller for BMS integration or networked Automated Demand Response with only a few additional components, please see networking page for additional details

- Fixture integrated NX sensors can be used for both occupancy sensing and daylight harvesting when required
- For outdoor spaces, wireless enabled fixtures and radios shall be within 300' line of sight of at least two other wireless devices
- Space can be networked back to an Area Controller for BMS integration or networked Automated Demand Response with only a few additional components, please see networking page for additional details

The NX Lighting Controls System provides all the building blocks necessary for a secure, on-premise enterprise lighting management system. The system not only controls lighting, but also provides actionable information to Building Owners and Facility Managers to create energy efficient spaces and improve occupant experience.

NX LIGHTING CONTROL SYSTEM

- Network of device and luminaires organized by Areas / Zones / Groups (AZG)
- NX wired & wireless devices and connected luminaires control lighting using relays and 0-10V dimming
- Wired devices connect using CAT5 cables and provide auto-configuration for basic code compliance
- Wireless devices are grouped together and communicate using secure AES 128-bit encrypted 2.4GHz wireless mesh technology based on the IEEE 802.15.4 standard. Network bridges manage NX Zones and connect wired and wireless zones to the NX Network
- NX Lighting Controls mobile app provides simple tool for quick device and system adjustments
- The NX Area Controller with Site Manager provides Building Owners & Facility Managers with multi-building lighting control, insights into their lighting system, and integration with Building Management Systems (BMS)

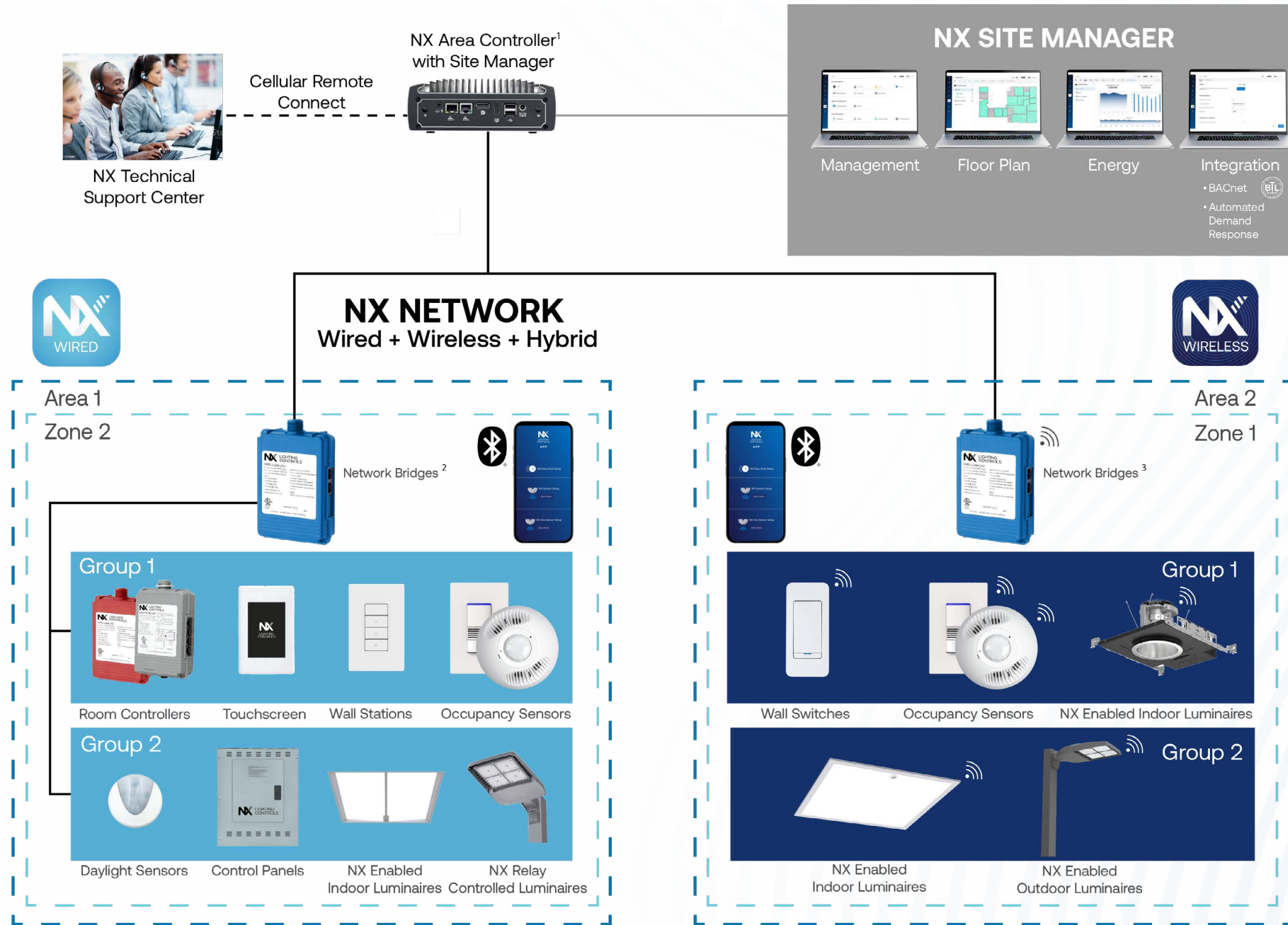

SITE MANAGER

- Intuitive web-based, comprehensive lighting management console
- Visual insights into energy usage
- Manage lighting schedules
- Quickly respond to requests for light level changes or reported issues from floor plan views
- Integrate the lighting system to any BACnet compatible Building Management System (BMS)

PLATFORM SNAPSHOT

Space Type	Architecture	Deployment	Connectivity	Integration Options	Advance Solutions
Interior & Exterior	Distributed	Standalone & Network	Wired, Wireless, Hybrid	Contacts, BACnet™, OpenADR 2.0a/2.0b	SpectraSync™

The NX Lighting Controls system offers a completely integrated UL924 solution for emergency lighting controls that is less complicated and easier to install than classic standalone ALCR and BCELTS solutions. The NX UL924 Load Controller removes the need for complicated installations and wiring normally associated with UL924 solutions. The NX UL924 Load Controller senses normal power using a standard CAT5 connection to a NX Room Controller connected to normal power. In the event there is a loss of normal power the NX UL924 Load Controller will automatically bring the lights to full brightness, regardless of their current state. When normal power is restored all lighting returns to normal operation.

- UL924 Listed emergency lighting control device
- Meets NFPA Article 700 requirements for emergency lighting
- Single relay version with dual 0-10V interface for full range dimming control
- Automatically overrides lighting to emergency state upon loss of normal power
- Utilizes CAT5 connection to standard NX room controller for normal power sensing
- Full range continuous dimming defaults to full ON in emergency mode
- FX bus enabled and compatible with NXRCFX room controllers
- Provision for remote test button or fire alarm interface
- Advanced configuration, power metering, and control through either NX Area Controller or NX Lighting Controls mobile app

NX UL924 SOLUTION

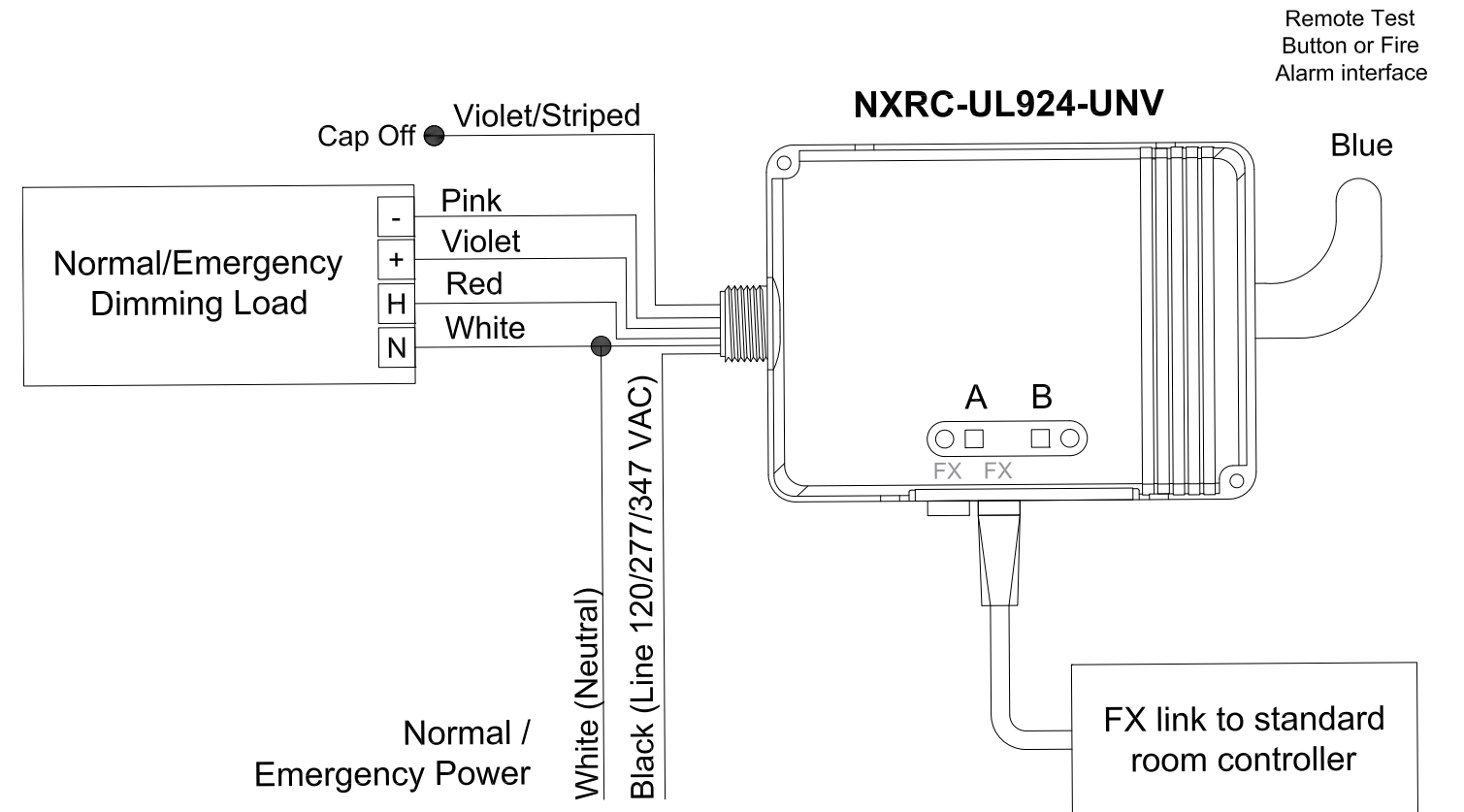

The NX Lighting Controls mobile app helps provide quick, simple installation, and programming right in the palm of your hand.

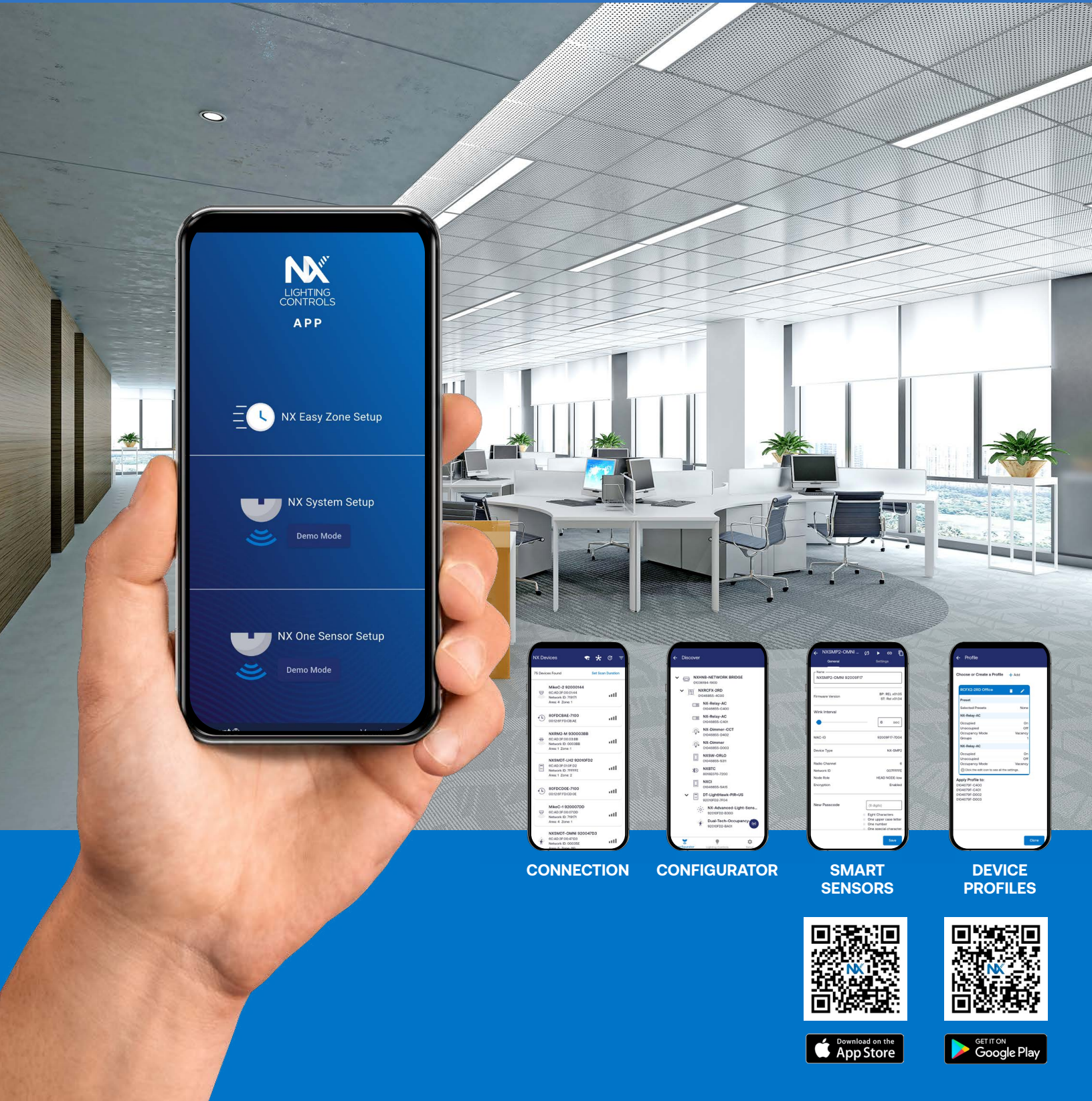

The NX Lighting Controls mobile app is a free to use mobile application for programming both an NX Lighting Controls System or Standalone Bluetooth® Sensors. The app allows you to discover and configure wired and wireless devices and setup groups and zones for both standalone and networked NX sites. The app also provides access to IntelliSCOPE™ for real time occupancy data with any digital NX or standalone Bluetooth® sensor. The NX Lighting Controls mobile app is available for download on both Apple iOS and Android devices.

- Enables easy setup, configuration and diagnostics of standalone Bluetooth® sensors, NX room devices and NXP2 lighting control panels via Bluetooth® BLE
- Create custom holidays, schedules, and presets (lighting scenes)
- Set geographical location of site for sunrise/sunset schedules
- Simple configuration of relay and dimmer settings for selected areas and zones
- Passcode protected to prevent unauthorized access to system
- Supports OTA (Over The Air) device updates
- Features IntelliSCOPE™ diagnostic tool for real-time calibration and testing of NX digital smart sensors

All NX wireless sensors come enabled with our proprietary IntelliSCOPE™ functionality, which provides true ladder-less programming and installation all with the click of a button.

IntelliSCOPE™ provides real-time occupancy data to help optimize sensor detection in any application, which helps save time and money.

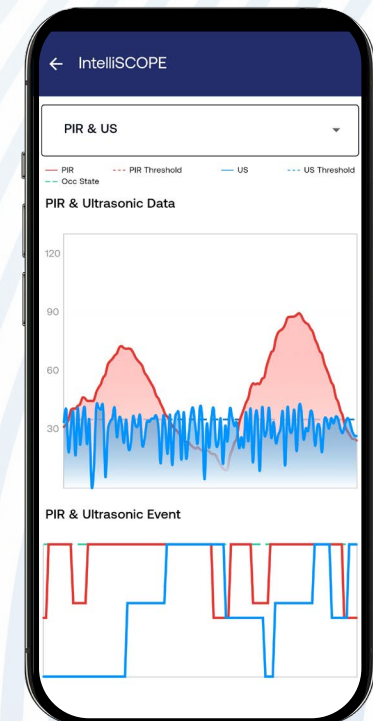

PRODUCT CATALOG

CATALOG NO.	DESCRIPTOR	COLORS
AREA CONTROLLERS		
NXAC2-120-SM	NX Area Controller V2 w/ NX Site Manager, NX Network, BACnet, 120V	Black
NXAC2-120-SMA	NX Area Controller V2 w/NX Site Manager Adapter, NX Network, 120V	Black
NETWORK DEVICES		
NXHNB2	NX Network Bridge Module, Connects Wired and Wireless Zones to NX Network, Internal Time Clock, Low Voltage	Blue
NXPOE-7-24B	NX POE Switch/Power Injector, Seven RJ45 Powered NX Network Ports, One RJ45 Powered Uplink Port, 24VDC Power Supply (Included)	Black
NX-EOF-MC-01	NX Media Converter, Ethernet Over Fiber, Copper: Single RJ45 Port (10/100BASE-T), Fiber: ST Connector (100BASE-X), 120V	Gray
ROOM CONTROLLERS		
NXRCFX2-1RD-UNV	NX Room Controller, FX Bus Compatible, 1 Relay, 0-10V Dimming, Universal Voltage	Gray
NXRCFX2-2RD-UNV	NX Room Controller, FX Bus Compatible, 2 Relay, 0-10V Dimming, Universal Voltage	Gray
NXRC-UL924-UNV	UL924 Emergency Load Controller, 1 Relay, 0-10V Dimming, Universal Voltage	Red
OCCUPANCY SENSORS		
NXSMDT-OMNI-XX	NX Digital Smart Occupancy Sensor, Ceiling Mount, PIR and Ultrasonic, with Daylight Harvesting, Integrated Bluetooth®, mini SmartPORT	White, Black, Gray
NXSMDT-LHO-XX	NX Digital Smart Occupancy Sensor, Wall Switch, PIR and Ultrasonic, with Daylight Harvesting, Integrated Bluetooth®, Dual RJ45 SmartPORT, 0 Button	White, Black, Gray, Ivory, Light Almond, Red
NXSMDT-LH1-XX	NX Digital Smart Occupancy Sensor, Wall Switch, PIR and Ultrasonic, with Daylight Harvesting, Integrated Bluetooth®, Dual RJ45 SmartPORT, 1 Button	White, Black, Gray, Ivory, Light Almond, Red
NXSMDT-LH2-XX	NX Digital Smart Occupancy Sensor, Wall Switch, PIR and Ultrasonic, with Daylight Harvesting, Integrated Bluetooth®, Dual RJ45 SmartPORT, 2 Button	White, Black, Gray, Ivory, Light Almond, Red
NXSMIR-LHO-XX	NX Digital Smart Occupancy Sensor, Wall Switch, PIR, with Daylight Harvesting, Integrated Bluetooth®, Dual RJ45 SmartPORT, 0 Button	White, Black, Gray, Ivory, Light Almond, Red
NXSMIR-LH1-XX	NX Digital Smart Occupancy Sensor, Wall Switch, PIR, with Daylight Harvesting, Integrated Bluetooth®, Dual RJ45 SmartPORT, 1 Button	White, Black, Gray, Ivory, Light Almond, Red
NXSMIR-LH2-XX	NX Digital Smart Occupancy Sensor, Wall Switch, PIR, with Daylight Harvesting, Integrated Bluetooth®, Dual RJ45 SmartPORT, 2 Button	White, Black, Gray, Ivory, Light Almond, Red
INTEGRATED SENSORS		
NXSMP2-OMNI	NX Digital Smart PIR Occupancy Sensor with Photocell and Bluetooth® Programming, 360° Lens	White, Black, Gray
NXSMP2-LMI	NX Digital Smart PIR Occupancy Sensor with Photocell and Bluetooth® Programming, Low Mount/Indoor, 360° Lens	White, Black, Gray
NXSMP2-HMO	NX Digital Smart PIR Occupancy Sensor with Photocell and Bluetooth® Programming, High Mount/Outdoor, 360° Lens	White, Black, Gray
NXSMP2-LMO	NX Digital Smart PIR Occupancy Sensor with Photocell and Bluetooth® Programming, Low Mount/Outdoor, 360° Lens	White, Black, Gray
DAYLIGHT SENSORS		
NXDS	NX Daylight Sensor	White
NXDS-O	NX Daylight Sensor Outdoor	White

CATALOG NO.	DESCRIPTOR	COLORS
WALL SWITCHES		
NXSW2-1-XX	NX Digital Smart Switch, 1 Button, Momentary, Pilot	White, Black, Gray, Ivory, Light Almond, Red
NXSW2-2-XX	NX Digital Smart Switch, 2 Button, Momentary, Pilot	White, Black, Gray, Ivory, Light Almond, Red
NXSW2-3-XX	NX Digital Smart Switch, 3 Button, Momentary, Pilot	White, Black, Gray, Ivory, Light Almond, Red
NXSW2-4-XX	NX Digital Smart Switch, 4 Button, Momentary, Pilot	White, Black, Gray, Ivory, Light Almond, Red
NXSW2-5-XX	NX Digital Smart Switch, 5 Button, Momentary, Pilot	White, Black, Gray, Ivory, Light Almond, Red
NXSW2-6-XX	NX Digital Smart Switch, 6 Button, Momentary, Pilot	White, Black, Gray, Ivory, Light Almond, Red
NXSW2-8-XX	NX Digital Smart Switch, 8 Button, Momentary, Pilot	White, Black, Gray, Ivory, Light Almond, Red
NXSW2-ORLO-XX	NX Digital Specialty Switch, On/Raise/Lower/Off	White, Black, Gray, Ivory, Light Almond, Red
NXSW2-OO-XX	NX Digital Specialty Switch, On/Off	White, Black, Gray, Ivory, Light Almond, Red
NXSW2-SS-XX	NX Digital Specialty Switch, Scene Switch	White, Black, Gray, Ivory, Light Almond, Red
NXSW2-CCT-XX	NX Digital Specialty Switch, CCT	White, Black, Gray, Ivory, Light Almond, Red
NXSW2-W1-XX	NX Wireless AC Powered Smart Switch, 1 Button, Momentary, Pilot	White, Black, Gray, Ivory, Light Almond, Red
NXSW2-W2-XX	NX Wireless AC Powered Smart Switch, 2 Button, Momentary, Pilot	White, Black, Gray, Ivory, Light Almond, Red
NXSW2-W3-XX	NX Wireless AC Powered Smart Switch, 3 Button, Momentary, Pilot	White, Black, Gray, Ivory, Light Almond, Red
NXSW2-W4-XX	NX Wireless AC Powered Smart Switch, 4 Button, Momentary, Pilot	White, Black, Gray, Ivory, Light Almond, Red
NXSW2-W5-XX	NX Wireless AC Powered Smart Switch, 5 Button, Momentary, Pilot	White, Black, Gray, Ivory, Light Almond, Red
NXSW2-W6-XX	NX Wireless AC Powered Smart Switch, 6 Button, Momentary, Pilot	White, Black, Gray, Ivory, Light Almond, Red
NXSW2-W8-XX	NX Wireless AC Powered Smart Switch, 8 Button, Momentary, Pilot	White, Black, Gray, Ivory, Light Almond, Red
NXSW2-WORLO-XX	NX Wireless AC Powered Specialty Switch, On/Raise/Lower/Off	White, Black, Gray, Ivory, Light Almond, Red
NXSW2-WOO-XX	NX Wireless AC Powered Specialty Switch, On/Off	White, Black, Gray, Ivory, Light Almond, Red
NXSW2-WSS-XX	NX Wireless AC Powered Specialty Switch, Scene Switch	White, Black, Gray, Ivory, Light Almond, Red
NXSW2-WCCT-XX	NX Wireless AC Powered Specialty Switch, CCT	White, Black, Gray, Ivory, Light Almond, Red
NXSW2-KEY-MNTD1-XX	NX Digital Specialty Key Switch, Maintained 1 Pole/Single Throw	White, Black, Gray, Ivory, Light Almond, Red
NXSW2-KEY-MTRY1-XX	NX Digital Specialty Key Switch, Momentary 1 Pole/Single Throw	White, Black, Gray, Ivory, Light Almond, Red
NXSW-TH3-WH	NX SimpleTouch 3.5" full color graphic wall station	White
INTERFACES		
NXCI	NX Contact Closure Interface Module, Removable Terminal Block with 2 Switch Inputs, Dual RJ45 SmartPORTS	Silver
NXAVM	NX Audio Visual Interface Module, Single DB9 Connector for RS232 Serial Communications, ASCII Based Command Set, Single RJ45 SmartPORT	Silver
NXRO	NX Occupancy Output Interface Module, Low Voltage Form C NO/NC Relay Output, Removable Terminal Block, Dual RJ45 SmartPORTS	Silver
NXHDI	NX Network Device Interface Module, Connects NXSP and NXCIO Devices to NX Network, Dual RJ45 SmartPORTS, DIN Rail Mount	Blue
NXSP	NX SmartPORT Module, 4 SmartPORTS (8 RJ45 Connectors), DIN Rail Mount	Blue
NXDCIO	NX Dry Contact Interface Module, 6 Low Voltage Inputs, 6 Form C NO/NC Outputs, DIN Rail Mount	Blue
NXOADR2-VEN-DC	NX OpenADR 2.0a/2.0b Bidirectional Virtual End Node (VEN) Module with Two NO/NC Dry Contact Outputs, 120V	Black

PRODUCT CATALOG

CATALOG NO.	DESCRIPTOR	COLORS
RADIO MODULES		
NXOFM-1R1D-UNV	NX 7-Pin On-Fixture Module, 1 Relay, 1 Dimmer, Universal Voltage (120V-480V)	Black
NXRM2-H	NX Network Radio Module with Bluetooth® Programming, 12 VDC, ISM 2.4GHz	White, Black, Gray
NXBTC	NX RJ45 Bluetooth® Radio Module with Time Server	Blue
ACCESSORIES		
NXRJSPLITTER	NX RJ45 Splitter 2-way Female for CAT5	Ivory
RJ45ADAPTER	NX RJ45 Splitter 2-way Female for CAT5	Gray
NXFRD-UNV	NX Forward & Reverse Phase Dimming Converter	Black
NXWPS	NX Wall Partition Sensor	White
LIGHTING CONTROL PANELS		
NXP2-PNL-8-8-U-S	NX Lighting Control Panel V2, 8 Relay Capacity, 8 Dimming Channels, 8-20A/Single Pole Latching Relays, 120/277VAC, Surface Mount	Gray
NXP2-PNL-8-0-U-S	NX Lighting Control Panel V2, 8 Relay Capacity, 8 Dimming Channels, Relays Not Included, 120/277VAC, Surface Mount	Gray
NXP2-PNL-16-16-U-S	NX Lighting Control Panel V2, 16 Relay Capacity, 16 Dimming Channels, 16-20A/Single Pole Latching Relays, 120/277VAC, Surface Mount	Gray
NXP2-PNL-16-0-U-S	NX Lighting Control Panel V2, 16 Relay Capacity, 16 Dimming Channels, Relays Not Included, 120/277VAC, Surface Mount	Gray
NXP2-PNL-24-24-U-S	NX Lighting Control Panel V2, 24 Relay Capacity, 24 Dimming Channels, 24-20A/Single Pole Latching Relays, 120/277VAC, Surface Mount	Gray
NXP2-PNL-24-0-U-S	NX Lighting Control Panel V2, 24 Relay Capacity, 24 Dimming Channels, Relays Not Included, 120/277VAC, Surface Mount	Gray
NXP2-PNL-32-32-U-S	NX Lighting Control Panel V2, 32 Relay Capacity, 32 Dimming Channels, 32-20A/Single Pole Latching Relays, 120/277VAC, Surface Mount	Gray
NXP2-PNL-32-0-U-S	NX Lighting Control Panel V2, 32 Relay Capacity, 32 Dimming Channels, Relays Not Included, 120/277VAC, Surface Mount	Gray
NXP2-PNL-48-48-U-S	NX Lighting Control Panel V2, 48 Relay Capacity, 48 Dimming Channels, 48-20A/Single Pole Latching Relays, 120/277VAC, Surface Mount	Gray
NXP2-PNL-48-0-U-S	NX Lighting Control Panel V2, 48 Relay Capacity, 48 Dimming Channels, Relays Not Included, 120/277VAC, Surface Mount	Gray
RELAYS		
NXP2-RL-SP	NX Lighting Control Panel V2 Relay, Single Pole, Latching, 120/227/347V, 20A- 50/60 Hz	Black
NXP2-RL-DP	NX Lighting Control Panel V2 Relay, Double Pole, Latching, 208/240/480V, 20A- 50/60 Hz	Black





CATALOG NO.	DESCRIPTOR	COLORS
NX IN-FIXTURE CABLES		
NXCBL-P-10	NX mini-Smart Port to Female RJ45 Plenum Cable, 10" length	Gray
NXCBL-P2-12	NX mini-Smart Port to Dual RJ45 Plenum Cable, 12" length	Gray
CAT5 SYSTEM CABLES		
CAT5-3IN-OR-PLENUM	CAT5 Cable, Plenum Rated, 3IN	Orange
CAT5-3F-OR-PLENUM	CAT5 Cable, Plenum Rated, 3F	Orange
CAT5-10F-OR-PLENUM	CAT5 Cable, Plenum Rated, 10F	Orange
CAT5-25F-OR-PLENUM	CAT5 Cable, Plenum Rated, 25F	Orange
CAT5-50F-OR-PLENUM	CAT5 Cable, Plenum Rated, 50F	Orange
CAT5-100F-OR-PLENUM	CAT5 Cable, Plenum Rated, 100F	Orange

PRODUCT CATALOG

NX Integrated Control Options for Indoor Luminaires Ordering Logic and Description		CONTROL OPTION FUNCTIONALITY									CONTROL OPTION COMPONENTS		
		Networkable	Grouping	Scheduling	Occupancy/ Motion	Daylight Harvesting	0-10V Dimming	On/Off Control	Bluetooth® App Programming	Sensor Max Height			
NX Wireless	NXW	NX Networked Wireless Radio Module NXRM2 and Bluetooth® Programming, without Sensor	✓	✓	✓	-	-	✓	✓	✓	-		NXRM2-H
	NXWSM	NX Networked Wireless Enabled Integral NXSMP2-SMI PIR Occupancy Sensor with Automatic Dimming Photocell and Bluetooth® Programming	✓	✓	✓	✓	✓	✓	✓	✓	12FT		NXSMP2-SMI
	NXWRM	NX Networked Wireless Enabled Integral NXSMP2-LMI PIR Occupancy Sensor with Automatic Dimming Photocell and Bluetooth® Programming	✓	✓	✓	✓	✓	✓	✓	✓	12FT		NXSMP2-LMI
	NXWOM	NX Networked Wireless Enabled Integral NXSMP2-OMNI PIR Occupancy Sensor with Automatic Dimming Photocell and Bluetooth® Programming	✓	✓	✓	✓	✓	✓	✓	✓	14FT		NXSMP2-OMNI
	NXWLM	NX Networked Wireless Enabled Integral NXSMP2-LMO PIR Occupancy Sensor with Automatic Dimming Photocell and Bluetooth® Programming	✓	✓	✓	✓	✓	✓	✓	✓	16FT		NXSMP2-LMO
	NXWHM	NX Networked Wireless Enabled Integral NXSMP2-HMO PIR Occupancy Sensor with Automatic Dimming Photocell and Bluetooth® Programming	✓	✓	✓	✓	✓	✓	✓	✓	45FT		NXSMP2-HMO
NX Wired	NXE	NX Wired Dual RJ45 SmartPORTS, without Sensor	✓	✓	✓	-	-	✓	✓	✓	-		NXDSP
	NXESM	NX Wired Dual RJ45 SmartPORTS and Integral NXSMP2-SMI PIR Occupancy Sensor with Automatic Dimming Photocell and Bluetooth® Programming	✓	✓	✓	✓	✓	✓	✓	✓	12FT		NXDSP NXSMP2-SMI
	NXERM	NX Wired Dual RJ45 SmartPORTS and Integral NXSMP2-LMI PIR Occupancy Sensor with Automatic Dimming Photocell and Bluetooth® Programming	✓	✓	✓	✓	✓	✓	✓	✓	12FT		NXDSP NXSMP2-LMI
	NXEOM	NX Wired Dual RJ45 SmartPORTS and Integral NXSMP2-OMNI PIR Occupancy Sensor with Automatic Dimming Photocell and Bluetooth® Programming	✓	✓	✓	✓	✓	✓	✓	✓	14FT		NXDSP NXSMP2-OMNI
	NXELM	NX Wired Dual RJ45 SmartPORTS and Integral NXSMP2-LMO PIR Occupancy Sensor with Automatic Dimming Photocell and Bluetooth® Programming	✓	✓	✓	✓	✓	✓	✓	✓	16FT		NXDSP NXSMP2-LMO
	NXEHM	NX Wired Dual RJ45 SmartPORTS and Integral NXSMP2-HMO PIR Occupancy Sensor with Automatic Dimming Photocell and Bluetooth® Programming	✓	✓	✓	✓	✓	✓	✓	✓	45FT		NXDSP NXSMP2-HMO

*Please reference Current luminaire specification sheets for option availability.

PRODUCT CATALOG

NX Integrated Control Options for Outdoor Luminaires Ordering Logic and Description		CONTROL OPTION FUNCTIONALITY								Sensor Max Height	CONTROL OPTION COMPONENTS			
		Networkable	Grouping	Scheduling	Occupancy	Daylight Harvesting	0-10V Dimming	On/Off Control	Bluetooth® App Programming					
NX Wireless	NXOFM-1RID-UNV <small>(sold separate from luminaire)</small>	NX 7-Pin Twist-Lock® with NX Networked Wireless Radio, Integral Automatic Dimming Photocell, Integral Single Pole Relay with Dimming, and Bluetooth® Programming		✓	✓	✓	-	✓	✓	✓	✓	-		NXOFM-1RID-UNV
	NXW	NX Networked Wireless Radio Module NXRM2 and Bluetooth® Programming, without Sensor		✓	✓	✓	-	-	✓	✓	✓	-		NXRM2-H
	NXWS12F	NX Networked Wireless Enabled Integral NXSMP2-OMNI-O PIR Occupancy Sensor with Automatic Dimming Photocell and Bluetooth® Programming		✓	✓	✓	✓	✓	✓	✓	✓	14FT		NXSMP2-OMNI-O
	NXWS16F	NX Networked Wireless Enabled Integral NXSMP2-LMO PIR Occupancy Sensor with Automatic Dimming Photocell and Bluetooth® Programming		✓	✓	✓	✓	✓	✓	✓	✓	16FT		NXSMP2-LMO
	NXWS40F	NX Networked Wireless Enabled Integral NXSMP2-HMO PIR Occupancy Sensor with Automatic Dimming Photocell and Bluetooth® Programming		✓	✓	✓	✓	✓	✓	✓	✓	40FT		NXSMP2-HMO

*Please reference Current luminaire specification sheets for option availability.

Comprehensive Support Options to Meet Project Needs

Contact Us

Call (800) 888-8006 and select one of the options listed below



Tech Support Hours: 7:00am - 7:00pm EST, Monday - Friday

Quotes, Applications, Layouts and Submittal Requests:
controls-Design@currentlighting.com

Technical Support (troubleshooting, specifications, programming):

currentlighting.com/controls/technical-services



Phone and Remote Support

While it is our goal to provide you with intelligent, simple and scalable control solutions, customer experience level and project complexity may necessitate additional support during the design development, construction and post-occupancy stages of a project. The support team is available for consultation to evaluate multiple control scenarios to identify the ideal lighting control device or system to meet energy code requirement and customer criteria. Additionally, our team of friendly and experienced professionals is enabled to assist on-site personnel, such as installation contractors, third party integrators, certified field technicians and facilities personnel, to quickly resolve issues and provide additional support.

Warranty

Current provides a 5-year limited warranty for LED luminaires and Lighting Controls devices.



On-site Support

Current offers on-site support service to ensure your project goes smoothly. While Current products are designed with simplicity in mind, some projects may benefit from a Field Service Engineer to perform an on-site pre-installation walk-through, after-hours and remote startup assistance, occupant training, sensor tuning, preset programming and other pre/post-occupancy services.

Design Services



Our team of lighting control system design professionals are available to provide sensor layouts, networked system design services and third party integration support for new and retrofit projects. Our goal is to provide you with on-time and accurate delivery of design deliverables optimized for your specific application, compliant with local building codes and project specifications.

The Institute

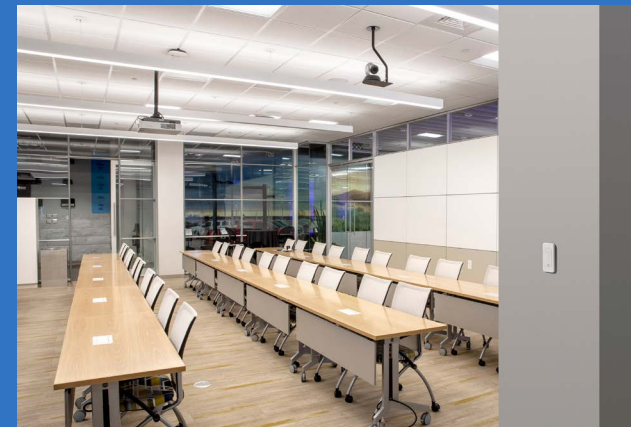

Classroom Education

Current offers cutting edge educational opportunities at Institute facilities across the United States. Our headquarters, located in Greenville, SC houses one of the industries largest training facilities with over 25,000 square-feet and is engineered to present a total solutions approach to your lighting and controls challenges.

Additionally, we have dedicated Institute facilities in North Carolina and Texas as well as Current facility classrooms for in-person instruction across the United States.

Virtual Education

Current's virtual education opportunities cover many facets of the lighting and controls industry including fundamentals, trends, technology, and product solutions. In addition, we can provide accredited continuing education (CEU) modules to help you maintain your certifications.

Engage with us in a way that's best for you!

- An online university with modules designed for self pace individual learning consumed on-demand.
- Live (private) instructor-led training private events for individuals within your own organization designed specifically for your needs.
- Live (public) instructor led training public events highlighting new technologies, continuing education, and lighting trends.





HLI Solutions, Inc.

701 Millennium Blvd.
Greenville, SC 29607

currentlighting.com/nx-lighting-controls

© 2025 HLI Solutions, Inc. All rights reserved. Information and specifications subject to change without notice. All values are design or typical values when measured under laboratory conditions.

Rev 12/10/25

NX_IECC_ApplicationGuide_R08