

CUSTOMER NAME \_\_\_\_\_  
 PROJECT NAME \_\_\_\_\_  
 DATE \_\_\_\_\_ TYPE \_\_\_\_\_  
 CATALOG NUMBER \_\_\_\_\_

## RTSE Series Poles

### Round/Tapered/Steel

Lighting installations for side and top mounting of luminaires with effective projected area (EPA) not exceeding maximum allowable loading of the specified pole in its installed geographic location.



### Construction

<b>Shaft:</b>	One-piece tapered steel with round cross section, Minimum yield of 55,000 psi; Steel base plate with axial bolt circle slots welded flush to pole shaft having minimum yield of 36,000 psi (ASTM A36) Pole shafts taper at .14"/ft.
<b>GROUP 1</b>	
<b>Anchor Bolts:</b>	Supplied with (4) galvanized anchor bolts with minimum yield of 55,000 psi (ASTM F1554). Galvanized hardware with two washers and two nuts per bolt for leveling
<b>Bolt Covers:</b>	Individual anchor bolt nut covers provided as standard
<b>Base Cover:</b>	Optional two-piece square base cover available
<b>Pole Cap:</b>	Pole shaft supplied with removable cover when applicable; Tenon and post-top configurations also available
<b>Hand Hole:</b>	4" X 6.5" handhole opening with cover and grounding provision. The handhole is located 18" from the base of the pole.
<b>GROUP 2</b>	
<b>Anchor Bolts:</b>	Supplied with (3) galvanized anchor bolts with minimum yield of 55,000 psi (ASTM F1554). Galvanized hardware with two washers and two nuts per bolt for leveling. Top nut is acorn nut.
<b>Pole Cap:</b>	3" pole top standard; Supplied with removable cover when applicable; Tenon configurations also available
<b>Handhole:</b>	3" X 5" handhole opening with cover and grounding provision. The handhole is located 18" from the base of the pole.
<b>GROUP 3</b>	
<b>Anchor Bolts:</b>	Supplied with (4) galvanized anchor bolts with minimum yield of 55,000 psi (ASTM F1554). Galvanized hardware with two washers and two nuts per bolt for leveling
<b>Base Cover:</b>	Two-piece square base cover supplied as standard
<b>Pole Cap:</b>	Pole shaft supplied with removable cover when applicable; Tenon and post-top configurations also available
<b>Handhole:</b>	4" X 6.5" handhole opening with cover and grounding provision. The handhole is located 18" from the base of the pole.

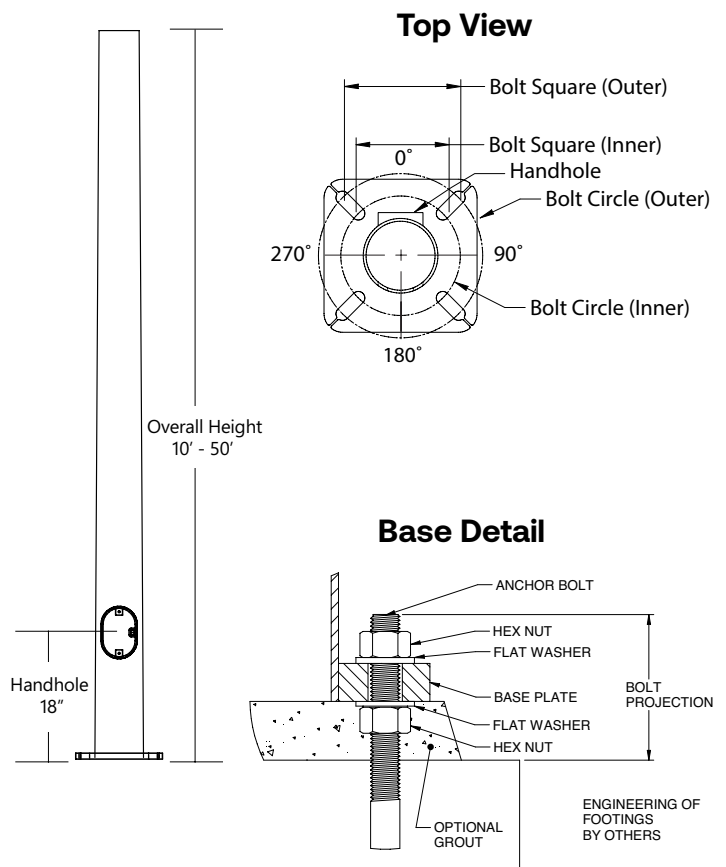

### Finish

- Durable thermoset polyester powder coat paint finish with nominal 3.0 mil thickness
- Powder paint prime applied over "white metal" steel substrate cleaned via mechanical shot blast method
- Decorative finish coat available in three standard colors; Custom colors available; RAL number preferable

### Example: RTSE20-40A-2-E1-DKBZ-SBC

#### RTSE

#### E1

SERIES	HEIGHT	SHAFT	THICKNESS	MOUNTING	POLE DRILLING	FINISH	OPTIONS
RTSE = Evolve Round Tapered Steel Pole	10=10 ft.	50=4.4x3.0" Round	A=.119"	<b>1</b> = Single arm mount <b>2</b> = Two fixtures at 180° <b>2L</b> = Two fixtures at 90° <b>3T</b> = Three fixtures at 90° <b>3Y</b> = Three fixtures at 120° <b>4</b> = Four fixtures at 90° <b>TA</b> = Tenon (2.375" OD) <b>TB</b> = Tenon (2.875" OD) <b>TC</b> = Tenon (3.5" OD) <b>OT</b> = No drilling (includes pole cap)	E1 = Evolve Round Pole	<b>DKBZ</b> = Dark Bronze <b>BLCK</b> = Black <b>GRAY</b> = Gray <i>* Contact factory for custom color options</i>	<b>GFI</b> <sup>1</sup> = 20 Amp GFCI Receptacle and Cover <b>EHH</b> <sup>1</sup> = Extra Handhole <b>C05</b> <sup>1</sup> = 0.5" Coupling <b>C07</b> <sup>1</sup> = 0.75" Coupling <b>C20</b> <sup>1</sup> = 2" Coupling <b>MPB</b> <sup>1</sup> = Mid-pole Luminaire Bracket <b>VM2</b> = 2nd mode vibration damper <b>LAB</b> = Less Anchor Bolts <b>SBC</b> = Square Base Cover
	12=12 ft.	50=4.7x3.0" Round	A=.119"				
	14=14 ft.	50=5.0x3.0" Round	A=.119"				
	16=16 ft.	50=5.2x3.0" Round	A=.119"				
	18=18 ft.	50=5.5x3.0" Round	A=.119"				
	20=20 ft.	60=5.8x3.0" Round	A=.119"				
		65=6.5x3.7" Round	A=.119"				
	25=25 ft.	70=7.0x3.5" Round	A=.125"				
			B=.179"				
	30=30 ft.	80=8.0x3.8" Round	A=.125"				
			B=.179"				
	35=35 ft.	85=8.5x3.6" Round	A=.125"				
			95=9.5x4.6" Round				
	39=39 ft.	90=9.0x3.5" Round	A=.125"				
	40=40 ft.	90=9.0x3.6" Round	A=.119"				
			B=.179"				
45=45 ft.	10=10.0x3.7" Round	A=.119"					
50=50 ft.	10=10.0x3.0" Round	A=.119"					
		B=.179"					

<sup>1</sup>Specify option location using MOUNTING ORIENTATION logic shown below

### Mounting Orientation

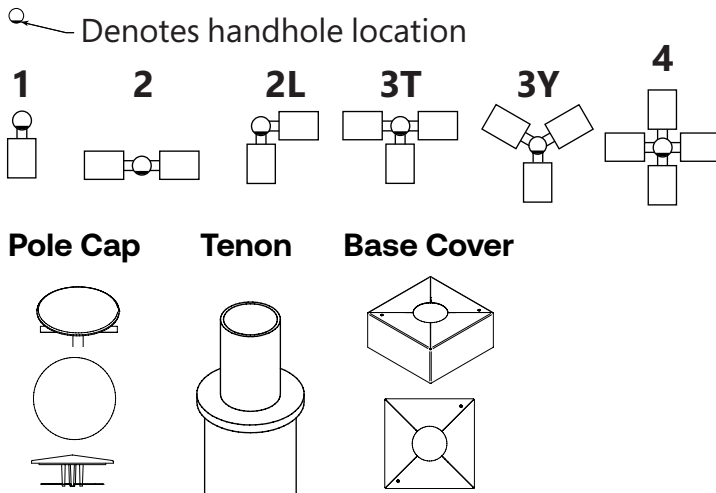

### DRILL PATTERN E1

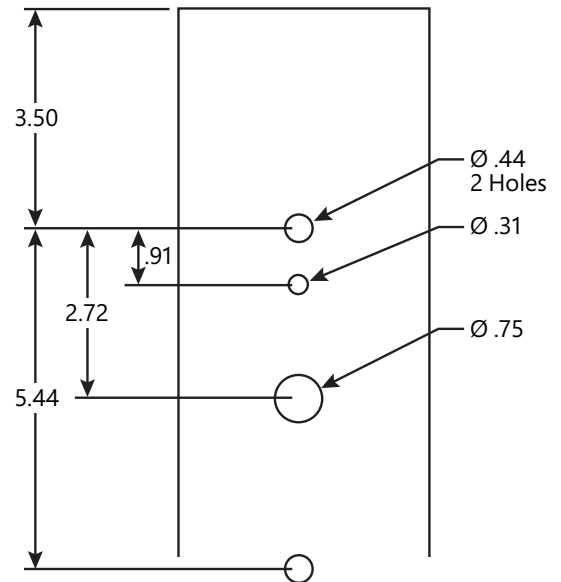

### ACCESSORIES- Order Separately

CATALOG NUMBER	DESCRIPTION
VM2SXX*	2nd mode vibration damper

\* XX = 08 for 8', 12 for 12', 15 for 16', 20 for 20', and 24' for 24'

# Evolve®

## RTSE Series Poles

Round/Tapered/Steel

CUSTOMER NAME \_\_\_\_\_  
 PROJECT NAME \_\_\_\_\_  
 DATE \_\_\_\_\_ TYPE \_\_\_\_\_  
 CATALOG NUMBER \_\_\_\_\_

CATALOG NUMBER	HEIGHT		NOMINAL SHAFT DIMENSIONS	WALL THICKNESS	BOLT CIRCLE (SUGGESTED)	BOLT CIRCLE (RANGE)	BASE PLATE SQUARE	ANCHOR BOLT SIZE	BOLT PROJECTION	POLE WEIGHT
	FEET	METERS								
<b>GROUP 1</b>										
RTSE20-65A	20	6.1	6.5" x 3.7"	0.125"	10.0"	9.5" - 13.0"	12.5" - Square	1" x 36" x 4"	4.25"	187
RTSE25-70A	25	7.6	7.0" x 3.5"	0.125"	10.0"	10.0" - 13.0"	12.5" - Square	1" x 36" x 4"	4.25"	226
RTSE30-80A	30	9.1	8.0" x 3.8"	0.125"	11.0"	11.0" - 13.5"	12.5" - Square	1" x 36" x 4"	4.25"	290
RTSE35-85A	35	10.7	8.5" x 3.6"	0.125"	13.0"	11.5" - 13.5"	12.5" - Square	1" x 36" x 4"	4.25"	340
RTSE39-90A	39	11.9	9.0" x 3.5"	0.125"	13.0"	12.5" - 13.5"	12.5" - Square	1" x 36" x 4"	4.25"	382
<b>GROUP 2</b>										
RTSE10-50A	10	3.0	4.4" x 3.0"	0.119"	8"	8"	8.5" - Triangular	3/4" x 16" x 4"	3.5"	60
RTSE12-50A	12	3.7	4.7" x 3.0"	0.119"	8"	8"	8.5" - Triangular	3/4" x 16" x 4"	3.5"	70
RTSE14-50A	14	4.3	5.0" x 3.0"	0.119"	8"	8"	8.5" - Triangular	3/4" x 16" x 4"	3.5"	80
RTSE16-50A	16	4.9	5.2" x 3.0"	0.119"	8"	8"	8.5" - Triangular	3/4" x 16" x 4"	3.5"	95
RTSE18-50A	18	5.5	5.5" x 3.0"	0.119"	8"	8"	8.5" - Triangular	3/4" x 16" x 4"	3.5"	110
RTSE20-60A	20	6.1	5.8" x 3.0"	0.119"	8"	8"	8.5" - Triangular	3/4" x 16" x 4"	3.5"	125
<b>GROUP 3</b>										
RTSE25-70B	25	7.6	7.0" x 3.5"	0.179"	10.0"	9.5" - 10.5"	10.88" - Square	1" x 36" x 4"	4.25"	280
RTSE30-80B	30	9.1	8.0" x 3.8"	0.179"	11.0"	10.5" - 11.5"	11.5" - Square	1.25" x 42" x 6"	5.0"	380
RTSE35-95A	35	10.7	9.5" x 4.6"	0.119"	13.0"	12.5" - 13.5"	13.0" - Square	1" x 36" x 4"	4.25"	370
RTSE40-90A	40	12.2	9.0" x 3.6"	0.119"	12.5"	12.0" - 13.0"	12.38" - Square	1" x 36" x 4"	4.25"	355
RTSE40-90B	40	12.2	9.0" x 3.6"	0.179"	12.5"	12.0" - 13.0"	12.38" - Square	1.25" x 42" x 6"	5.0"	515
RTSE45-10A	45	13.7	10.0" x 3.7"	0.119"	13.5"	13.0" - 14.0"	14.0" - Square	1" x 36" x 4"	4.25"	450
RTSE50-10A	50	15.2	10.0" x 3.0"	0.119"	13.5"	13.0" - 14.0"	14.0" - Square	1" x 36" x 4"	4.25"	475
RTSE50-10B	50	15.2	10.0" x 3.0"	0.179"	13.5"	13.0" - 14.0"	14.0" - Square	1.25" x 42" x 6"	5.0"	680

- NOTES:**
- Factory supplied template must be used when setting anchor bolts. Current will deny any claim for incorrect anchorage placement resulting from failure to use factory supplied template and anchor bolts.

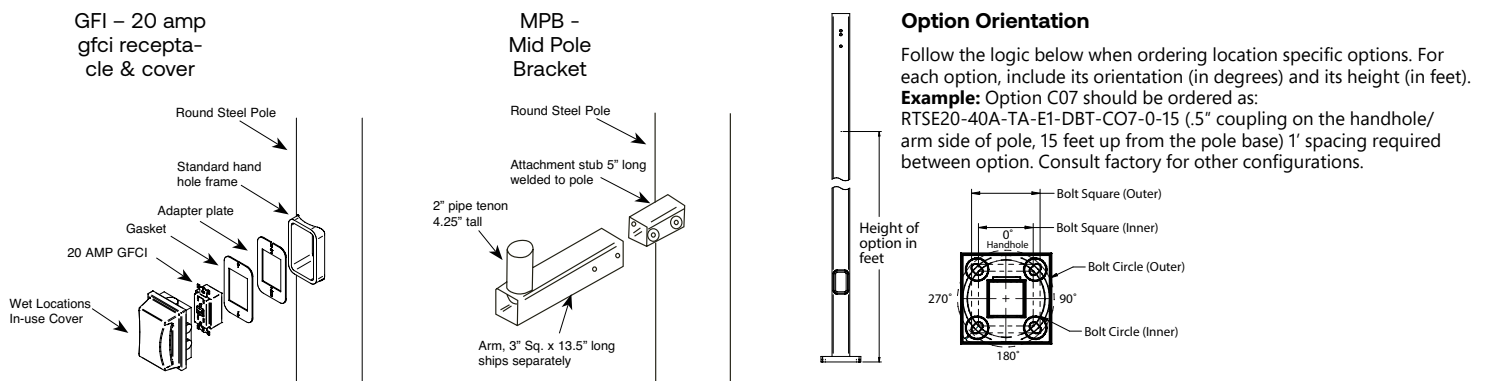
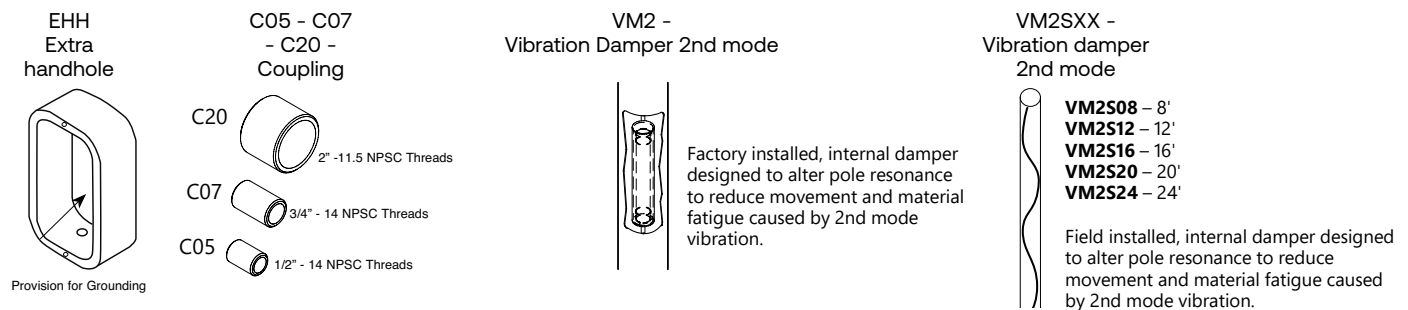

CUSTOMER NAME \_\_\_\_\_

PROJECT NAME \_\_\_\_\_

DATE \_\_\_\_\_ TYPE \_\_\_\_\_

CATALOG NUMBER \_\_\_\_\_

ASCE7-05 WIND MAP

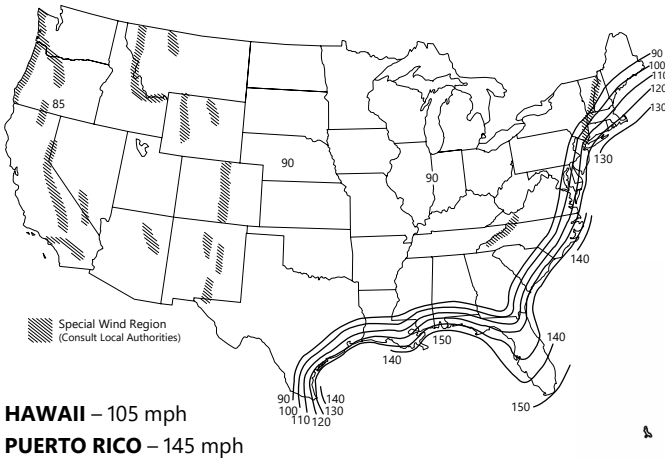

\*Printed with permission from ASCE

FLORIDA REGION WIND MAP

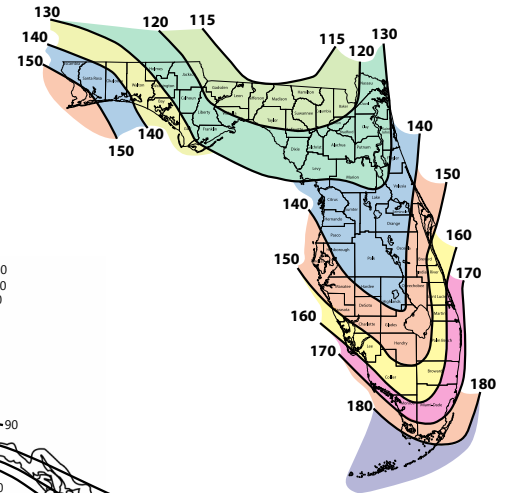

Florida region wind map above is based upon 3-second gust winds and the 2017 Florida Building Code

Alaska region wind map

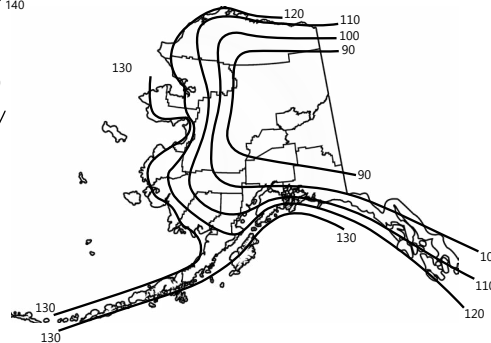

ASCE 7-05 wind map EPA Load Rating - 3 second gust wind speeds (Use for all locations except Florida)									
Catalog Number	Height	85	90	100	110	120	130	140	150
RTSE20-65A	20	23.1	21.5	17.4	14.4	10.0	8.3	7.0	6.0
RTSE25-70A	25	21.2	17.9	14.5	11.8	7.5	6.0	5.1	4.3
RTSE30-80A	30	19.5	15.2	12.1	9.8	7.1	5.8	4.8	3.9
RTSE35-85A	35	14.9	12.7	10.0	8.7	5.3	4.2	3.3	2.6
RTSE39-90A	39	13.4	10.6	8.3	6.5	4.5	3.3	2.4	1.8

Florida Building Code 2017 EPA Load Rating - 3 second gust wind speeds								
Catalog Number	115	120	130	140	150	160	170	180
RTSE20-65A	25.0	25.0	25.0	21.5	18.3	15.7	13.6	11.9
RTSE25-70A	25.0	23.0	19.2	16.1	13.6	11.5	9.8	8.4
RTSE30-80A	21.1	19.0	15.5	12.8	10.6	8.8	7.3	6.0
RTSE35-85A	17.1	15.3	12.3	9.9	8.0	6.4	5.1	1.0
RTSE39-90A	15.4	13.7	10.8	8.6	6.7	5.2	4.0	3.0

RTSE10-50A	10	22.0	21.5	17.4	14.4	12.0	10.1	8.7	7.5
RTSE12-50A	12	18.8	17.9	14.5	11.8	9.8	8.2	7.0	6.0
RTSE14-50A	14	17.7	15.2	12.1	9.8	8.1	6.7	5.6	4.8
RTSE16-50A	16	16.5	12.7	10.0	8.0	6.5	5.4	4.5	3.8
RTSE18-50A	18	14.0	10.6	8.3	6.5	5.2	4.2	3.5	2.9
RTSE20-60A	20	12.1	8.9	6.8	5.3	4.1	3.3	2.6	2.2

RTSE10-50A	21.8	20.2	17.2	14.7	12.7	11.2	9.7	8.7
RTSE12-50A	17.4	16.7	14.2	12.2	10.5	9.0	8.0	7.0
RTSE14-50A	15.0	14.2	12.0	10.0	8.7	7.5	6.5	5.7
RTSE16-50A	12.2	11.7	9.7	8.2	7.0	6.0	5.2	4.5
RTSE18-50A	11.1	9.7	8.0	6.7	5.5	4.7	4.0	3.5
RTSE20-60A	9.2	8.2	6.7	5.5	4.5	3.7	3.0	2.5

RTSE25-70B	25	25.0	22.6	18.1	14.7	12.2	10.3	8.8	7.6
RTSE30-80B	30	25.0	25.0	21.6	18.1	15.4	13.2	11.4	
RTSE35-95A	35	20.0	17.7	14.1	11.5	9.4	7.8	6.5	5.4
RTSE40-90A	40	15.5	13.6	10.6	8.3	6.7	5.4	4.4	3.6
RTSE40-90B	40	25.0	25.0	20.2	16.5	13.7	11.4	9.7	8.2
RTSE45-10A	45	12.4	10.8	8.1	6.1	4.8	3.7	2.9	2.1
RTSE50-10A	50	9.5	8.2	5.8	4.2	2.9	2.0	1.2	0.7
RTSE50-10B	50	19.2	17.4	13.6	10.7	8.5	6.9	5.5	4.4

RTSE25-70B	25.0	21.1	17.8	15.2	13.1	11.4	10.0	8.9
RTSE30-80B	25.0	30.2	25.7	22.2	19.4	17.0	15.0	13.4
RTSE35-95A	20.0	16.5	13.9	11.8	10.1	8.7	7.6	6.5
RTSE40-90A	15.5	12.6	10.4	8.6	7.3	6.1	5.2	4.5
RTSE40-90B	25.0	23.5	19.9	17.0	14.6	12.7	11.1	9.8
RTSE45-10A	12.4	9.9	8.0	6.5	5.3	4.3	3.5	2.9
RTSE50-10A	9.5	7.4	5.7	4.4	3.3	2.4	1.8	1.2
RTSE50-10B	19.2	16.1	13.3	11.1	9.3	7.8	6.6	5.6

## NOTES

---

- Allowable EPA, to determine max pole loading weight, multiply allowable EPA by 30 lbs.
- The tables for allowable pole EPA are based on the ASCE 7-05 Wind Map or the Florida Region Wind Map for the 2010 Florida Building Code. The Wind Maps are intended only as a general guide and cannot be used in conjunction with other maps. Always consult local authorities to determine maximum wind velocities, gusting and unique wind conditions for each specific application
- Allowable pole EPA for jobsite wind conditions must be equal to or greater than the total EPA for fixtures, arms, and accessories to be assembled to the pole. Responsibility lies with the specifier for correct pole selection. Installation of poles without luminaires or attachment of any unauthorized accessories to poles is discouraged and shall void the manufacturer's warranty
- Wind speeds and listed EPAs are for ground mounted installations. Poles mounted on structures (such as bridges and buildings) must consider vibration and coefficient of height factors beyond this general guide; Consult local and federal standards
- Wind Induced Vibration brought on by steady, unidirectional winds and other unpredictable aerodynamic forces are not included in wind velocity ratings. Consult Current's Pole Vibration Application Guide for environmental risk factors and design considerations:  
<http://images.salsify.com/image/upload/s--UkOLfj10--/bf7prkg0aey64uqoipso>
- Extreme Wind Events like, Hurricanes, Typhoons, Cyclones, or Tornadoes may expose poles to flying debris, wind shear or other detrimental effects not included in wind velocity ratings

**Due to our continued efforts to improve our products, product specifications are subject to change without notice.**