



Regulation Readiness

CANADA MERCURY PHASE-OUT

Current 



In an effort to regulate products with mercury, Canada has passed legislation that will gradually phase out Traditional mercury-containing lamps. The regulation effective date for each product category is shown in the table below. The phase out begins with the import & manufacture ban of Traditional lamps intended for new installations, followed by the import & manufacture ban of Replacement Fluorescent lamps. After these bans go into effect, retailers & distributors are permitted to sell off remaining inventory of Fluorescent lamps for a 2 year period. After this point in time, all Fluorescent Lamps will be prohibited for sale in Canada. Replacement High Intensity Discharge Lamps will continue to be allowed for sale under exemption.

Regulation Effective Date by Product Category

Regulation Type	Product Category				
	All Linear & Non-Linear Fluorescent	Screw Based Compact Fluorescent	Pin Based Compact Fluorescent	High Pressure Sodium Vapour High Intensity Discharge	Metal Halide High Intensity Discharge
Import and Manufacture Ban of Lamps for New Installations	1/1/2026	1/1/2026	1/1/2026	1/1/2029	1/1/2029
Replacement Lamps Exemption Period	From 1/1/2026 - 12/31/2027	None	From 1/1/2026 - 12/31/2027	Starting on 1/1/2029	Starting on 1/1/2029
Import and Manufacture Ban of Replacement Lamps	1/1/2028	None	1/1/2028	None	None
Selling Prohibition Start Date	1/1/2030	None	1/1/2030	None	None

Mercury in Fluorescent Lighting

Fluorescent technology was developed by General Electric in 1934. While the amount of mercury in each fluorescent lamp has significantly decreased over the past 90 years, a small amount is still required to produce light in all Discharge lamps. When electricity is applied to a fluorescent tube, mercury ions emit energy in the form of ultraviolet (UV) light. UV light is then converted into visible light by interacting with the phosphor coating on the inside of the glass tube. Mercury has electrical characteristics that cannot be matched by other materials and remains a key component of fluorescent lighting.

Mercury in High Intensity Discharge Lighting

High Intensity Discharge (HID) lamps have been around for more than 100 years. HID light sources emit light by vaporizing metallic salts inside an electric arc chamber resulting in a visible glow. Mercury Vapor lamps were the first commercially available HID lamps, and were patented by General Electric in 1913. Later in the 1960s, Metal Halide (MH) lamps and High Pressure Sodium (HPS) Lamps were invented. MH Lamps have high luminous efficacy and produce an intense white light. These lamps are used for general lighting both indoors and outdoors. HPS lamps are highly efficient but have a lower color rendering compared to other types of lamps. HPS lamps have been widely used in industrial and outdoor lighting. Similar to Fluorescent technology, mercury remains an essential component in all HID lamp types. The Canadian government has already banned the sale of Mercury Vapor HID Lamps as of 1/1/2018 (SOR 2014-254).

Transitioning to LED Lighting

LED (Light Emitting Diode) lamps do not contain mercury, and Current offers a variety of LED lamp options to replace Linear & Compact Fluorescent lamps and Mercury Vapor lamps. The different Types of LED lamps are explained in the following pages. Suggested LED replacements are noted for traditional lamps in the tables in this document. These are basic recommendations, but suitability should be evaluated for each specific application where traditional lamps were used. For more information about the transition from traditional lighting to LED, contact your Current sales representative.



LED Lamps – Tubes

LED Tubes, sometimes referred to as "TLEDs," are meant to use linear fluorescent sockets and fixtures. LED Tubes have the same length and pins as the linear fluorescent lamps they are intended to replace. The details of how the fixture is wired and the auxiliary equipment used may vary, depending on the LED Tube solution.

The lighting industry refers to three basic Types of LED Tubes:

-**Type A LED Tubes** are intended to be used as direct replacements for linear fluorescent lamps, with no modification to the fixture. Type A LED Tubes operate from fluorescent ballasts.

-**Type B LED Tubes** operate from mains voltage. The ballast is bypassed and the fixture is re-wired according to the installation instructions that come with the lamp. Wiring may vary across Type B LED Tubes from different manufacturers. A retrofit fixture label indicating the LED Tube used and that the fixture has been re-wired is provided to be applied to the fixture.

-**Type C LED Tubes** operate from dedicated remote (external) LED drivers. Instead of a ballast, a remote driver is used to provide the proper voltage and current for the Type C LED Tubes. A retrofit fixture label indicating the LED Tube and Driver used is provided to be applied to the fixture. Type C LED Tube and Driver solutions vary across the industry – they are not yet standardized like linear fluorescent lamps and ballasts.

There are also "hybrid" lamps that can cover multiple Types of LED Tubes, depending on how they are implemented.

Current offers a wide range of GE LED Tubes to replace linear fluorescent lamps, including all of the Types above. Each Type of LED Tube offers different advantages, so the right solution may vary by application.

Which LED Tube is right for you?

A basic comparison of the Types of LED Tubes is provided below. For more detailed information, please contact your Current sales representative.

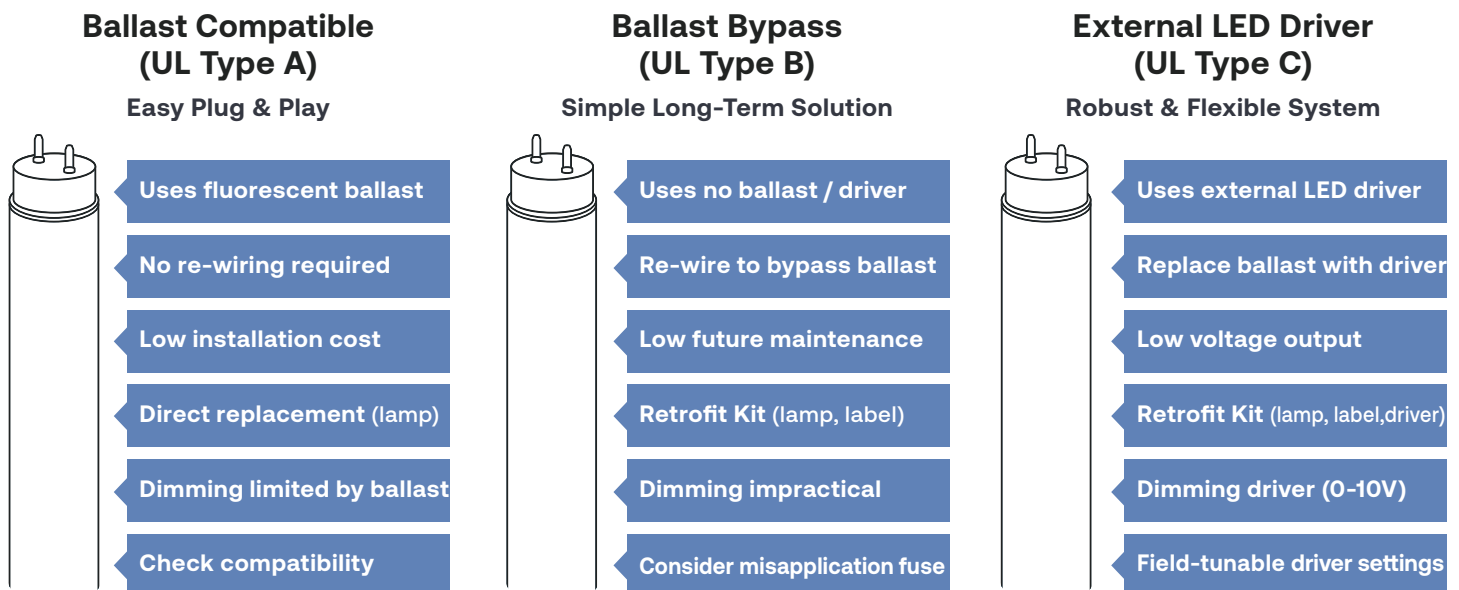



LED Tube Wiring Basics

The wiring diagrams below are provided as general guidance for GE LED Tubes. Other manufacturers' may vary. Refer to installation guides provided with GE LED Tubes for more detailed directions. If sockets are in good condition, no socket replacement should be necessary for GE LED Tubes. Add a jumper to non-shunted sockets, or tie both wires from a non-shunted socket to the incoming power as shown.

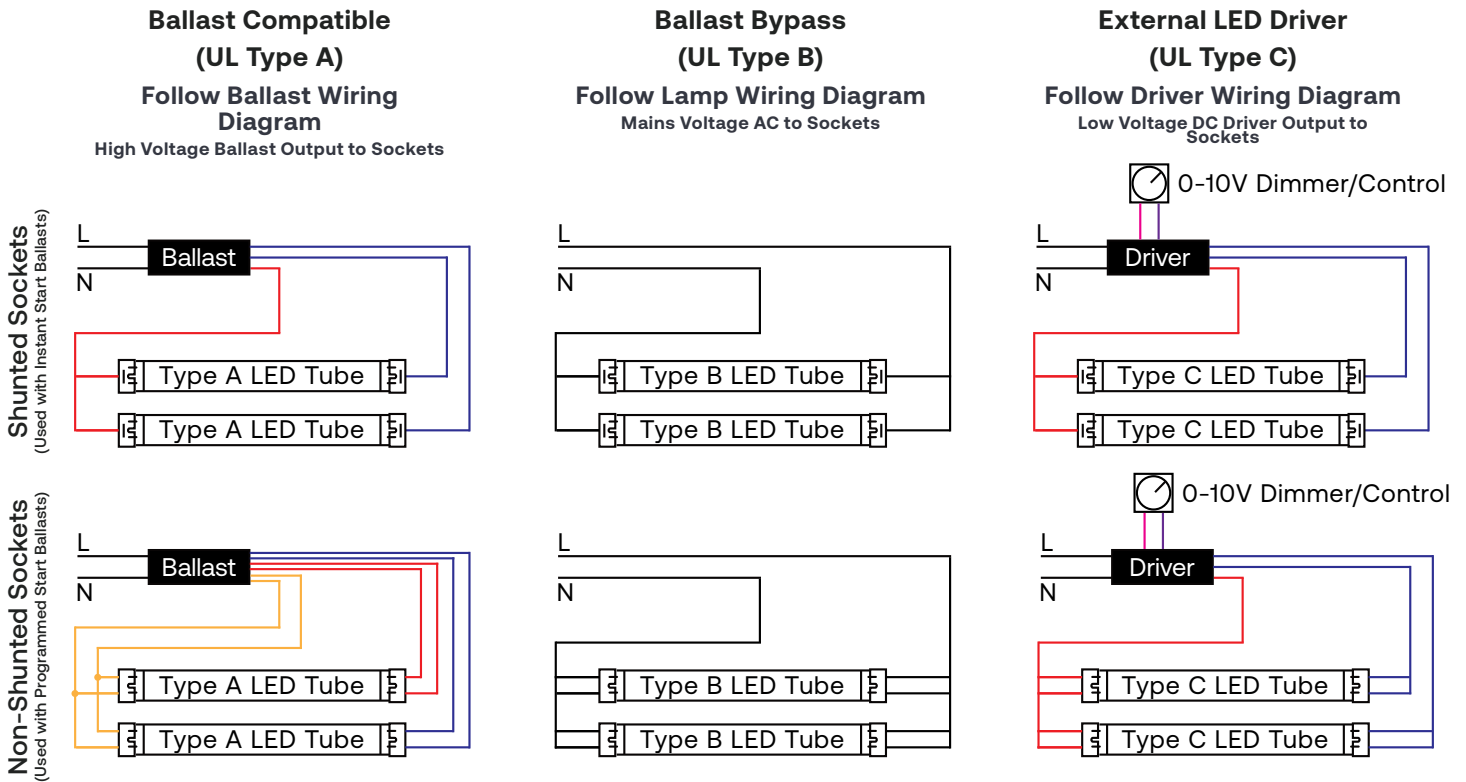

LED Tube Construction, Coating, & covRguard®:

GE LED Tubes are primarily constructed of glass tubes with an internal coating for diffusion. This is similar to linear fluorescent construction that has been used for decades. Glass is a stable material and works well for most applications. The coating inside the glass provides good diffusion, spreading out the light and eliminating hot spots and pixilation from the individual LEDs.

GE LED Tubes are also offered with PET coating. This white coating is heat-shrunk onto a clear glass tube. Diffusion is supplied by the PET coating, which also provides some shatter resistance. These lamps are NSF Splash Zone rated.

GE LED Tubes are also available with covRguard®. Similar to covRguard® on linear fluorescent lamps, a polycarbonate sleeve is applied over the glass tube and affixed to the lamp end caps. This construction provides excellent shatter protection. These lamps are NSF Food Zone (Non-contact) rated.



Regulation Readiness - Canada Mercury Phase-Out

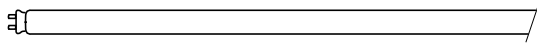

T5 (5/8" diameter) Miniature Bi-Pin Base (G5)



Min BiPin
G5

T5 Linear Fluorescent

T5 Linear Fluorescent Miniature Bi-Pin (G5)		Color Temp.	Ballast Bypass (Type B) LED Tube		Ballast Compatible (Type A) LED Tube		Remote Driver (Type C) LED Tube	
Order Code	Description		Order Code	Description	Order Code	Description	Order Code	Description
31590	F14W/T5/830/ECO	3000K	93128494	LED9BDT5G2/830HE	34403	LED7ET5/G2/830HE	38968	LEDT5/LC/G/2/830
46671	F14W/T5/835/ECO	3500K	93128495	LED9BDT5G2/835HE	34404	LED7ET5/G2/835HE	38980	LEDT5/LC/G/2/835
46673	F14W/T5/841/ECO	4100K	93128570	LED9BDT5G2/840HE	34411	LED7ET5/G2/840HE	38983	LEDT5/LC/G/2/840
46677	F21W/T5/830/ECO	3000K	93128488	LED11BDT5G3830HE	34371	LED10ET5G3/830HE	39000	LEDT5LC/G3/830HE
46684	F21W/T5/835/ECO	3500K	93128490	LED11BDT5G3835HE	34376	LED10ET5G3/835HE	39001	LEDT5LC/G3/835HE
46687	F21W/T5/841/ECO	4100K	93128491	LED11BDT5G3840HE	34401	LED10ET5G3/840HE	39002	LEDT5LC/G3/840HE
46704	F28W/T5/830/ECO	3000K	93128354	LED14BDT5G4830HE	34351	LED13ET5G4/830HE	38993	LEDT5LC/G4/830HE
46705	F28W/T5/835/ECO	3500K	93128355	LED14BDT5G4835HE	34354	LED13ET5G4/835HE	38995	LEDT5LC/G4/835HE
46706	F28W/T5/841/ECO	4100K	93128486	LED14BDT5G4840HE	34355	LED13ET5G4/840HE	38998	LEDT5LC/G4/840HE
46699	F24W/T5/830/ECO	3000K	93113793	LED11BDT5/G2/830	34413	LED11ET5/G/2/830	38968	LEDT5/LC/G/2/830
46700	F24W/T5/835/ECO	3500K	93114322	LED11BDT5/G2/835	34417	LED11ET5/G/2/835	38980	LEDT5/LC/G/2/835
46701	F24W/T5/841/ECO	4100K	93114323	LED11BDT5/G2/840	34418	LED11ET5/G/2/840	38983	LEDT5/LC/G/2/840
46744	F39W/T5/830/ECO	3000K	93114325	LED17BDT5/G3/830			38947	LEDT5/LC/G/3/830
46745	F39W/T5/835/ECO	3500K	93114626	LED17BDT5/G3/835			38948	LEDT5/LC/G/3/835
46759	F54W/T5/830/ECO	3000K	93100292	LED25BDT5/G4/830	19203	LED26ET5/G/4/830	38926	LEDT5/LC/G/4/830
46760	F54W/T5/835/ECO	3500K	93305599	LED25BDT5/G4/835/120-347	19221	LED26ET5/G/4/835	38934	LEDT5/LC/G/4/835
46761	F54W/T5/841/ECO	4100K	93305600	LED25BDT5/G4/840/120-347	19227	LED26ET5/G/4/840	38940	LEDT5/LC/G/4/840
46762	F54W/T5/850/ECO	5000K	93305601	LED25BDT5/G4/850/120-347	19348	LED26ET5/G/4/850	38946	LEDT5/LC/G/4/850
46763	F54W/T5/865/ECO	6500K	93305601	LED25BDT5/G4/850/120-347	19348	LED26ET5/G/4/850	38946	LEDT5/LC/G/4/850
68837	F54T5/XL/835/ECO	3500K	93305599	LED25BDT5/G4/835/120-347	19221	LED26ET5/G/4/835	38934	LEDT5/LC/G/4/835
71633	F14T5/835/WM/ECO	3500K	93128495	LED9BDT5G2/835HE	34404	LED7ET5/G2/835HE	38980	LEDT5/LC/G/2/835
71629	F54T5/841/WM/ECO	4100K	93305600	LED25BDT5/G4/840/120-347	19227	LED26ET5/G/4/840	38940	LEDT5/LC/G/4/840
62022	F54T5/47W/841/ECO	4100K	93305600	LED25BDT5/G4/840/120-347	19227	LED26ET5/G/4/840	38940	LEDT5/LC/G/4/840
10059	F8T5/CW	4100K						
10086	F13T5/CW	4100K						
81547	F28W/T5/835/ECO/CVG	3500K						
48458	F54T5/841/HO/ECO/CVG	4100K	93155904	LED25BDT5/G4/840/CVG				
80311	F54T5/850/HO/ECO/CVG	5000K	93155905	LED25BDT5/G4/850/CVG				

Regulation Readiness - Canada Mercury Phase-Out

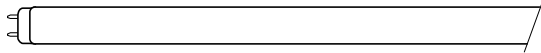

T8 (1" diameter) Medium Bi-Base (G13)

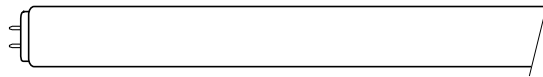

T12 (1-1/2" Diameter) Medium Bi-Pin Base (G13)

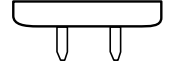

Med BiPin
G13

T8 Linear Fluorescent

T8 Linear Fluorescent Medium Bi-Pin (G13)		Color Temp.	Ballast Bypass (Type B) LED Tube		Ballast Compatible (Type A) LED Tube		Remote Driver (Type C) LED Tube	
Order Code	Description		Order Code	Description	Order Code	Description	Order Code	Description
45741	F17T8/SP30/ECO	3000K	93309179	LED7BDT8/G2/830/120-347	35775	LED8ET8/G/2/830	36406	LEDT8/LC/G/2/830
45743	F17T8/SP35/ECO	3500K	93309180	LED7BDT8/G2/835/120-347	35776	LED8ET8/G/2/835	36408	LEDT8/LC/G/2/835
45748	F17T8/SP41/ECO	4100K	93309181	LED7BDT8/G2/840/120-347	35778	LED8ET8/G/2/840	36409	LEDT8/LC/G/2/840
45754	F25T8/SP35/ECO	3500K	93309176	LED12BDT8/G3/835/120-347	35784	LED11ET8/G/3/835	36395	LEDT8/LC/G/3/835
45756	F25T8/SP41/ECO	4100K	93309177	LED12BDT8/G3/840/120-347	35788	LED11ET8/G/3/840	36398	LEDT8/LC/G/3/840
68850	F32T8/SPX30/ECO2	3000K	93305112	LED11BDT8/G4/830/120-347	34283	LED14ET8/G/4/830	34211	LEDT8/LC/G/4/830
68851	F32T8/SPX35/ECO2	3500K	93305113	LED11BDT8/G4/835/120-347	34289	LED14ET8/G/4/835	34227	LEDT8/LC/G/4/835
68852	F32T8/SPX41/ECO2	4100K	93305115	LED11BDT8/G4/840/120-347	34291	LED14ET8/G/4/840	34235	LEDT8/LC/G/4/840
68853	F32T8/SPX50/ECO2	5000K	93305116	LED11BDT8/G4/850/120-347	34300	LED14ET8/G/4/850	34239	LEDT8/LC/G/4/850
66342	F32T8/SPX65/ECO2	6500K	93305116	LED11BDT8/G4/850/120-347	34300	LED14ET8/G/4/850	34239	LEDT8/LC/G/4/850
72129	F32T8/25W/SPX35/ECO	3500K	93305113	LED11BDT8/G4/835/120-347	93107391	LED11ET8/G/4/835	34227	LEDT8/LC/G/4/835
72130	F32T8/25W/SPX41/ECO	4100K	93305115	LED11BDT8/G4/840/120-347	93107392	LED11ET8/G/4/840	34235	LEDT8/LC/G/4/840
72131	F32T8/25W/SPX50/ECO	5000K	93305116	LED11BDT8/G4/850/120-347	93107393	LED11ET8/G/4/850	34239	LEDT8/LC/G/4/850
72864	F28T8/XL/SPX35/ECO	3500K	93305113	LED11BDT8/G4/835/120-347	93107391	LED11ET8/G/4/835	34227	LEDT8/LC/G/4/835
72866	F28T8/XL/SPX41/ECO	4100K	93305115	LED11BDT8/G4/840/120-347	93107392	LED11ET8/G/4/840	34235	LEDT8/LC/G/4/840
72867	F28T8/XL/SPX50/ECO	5000K	93305116	LED11BDT8/G4/850/120-347	93107393	LED11ET8/G/4/850	34239	LEDT8/LC/G/4/850
10326	F32T8/XL/SPX35/HL/ECO	3500K	93305113	LED11BDT8/G4/835/120-347	34289	LED14ET8/G/4/835	34227	LEDT8/LC/G/4/835
10322	F32T8/XL/SPX41/HL/ECO	4100K	93305115	LED11BDT8/G4/840/120-347	34291	LED14ET8/G/4/840	34235	LEDT8/LC/G/4/840
42556	F32T8/XL/SPX50/HL/ECO	5000K	93305116	LED11BDT8/G4/850/120-347	34300	LED14ET8/G/4/850	34239	LEDT8/LC/G/4/850
72118	F31T8/SPX35/U/ECO	3500K	93107352	LED13BDT8/U/835			28084	LED14T8/U/835
72119	F31T8/SPX41/U/ECO	4100K	93107388	LED13BDT8/U/840			28164	LED14T8/U/840
28145	F32T8/SP30/U6/ECO	3000K	93133049	LED13BDT8/U6/830	43120	LED13ET8/U6/830	43131	LED15T8/G/U6/830
28149	F32T8/SP35/U6/ECO	3500K	93133050	LED13BDT8/U6/835	43125	LED13ET8/U6/835	43135	LED15T8/G/U6/835
28152	F32T8/SP41/U6/ECO	4100K	93133051	LED13BDT8/U6/840	43129	LED13ET8/U6/840	43143	LED15T8/G/U6/840
72112	F32T8/SPX35/U6/ECO	3500K	93133050	LED13BDT8/U6/835	43125	LED13ET8/U6/835	43135	LED15T8/G/U6/835
72113	F32T8/SPX41/U6/ECO	4100K	93133051	LED13BDT8/U6/840	43129	LED13ET8/U6/840	43143	LED15T8/G/U6/840
41126	F32T8SPX35ECOCVG	3500K	93154588	LED16BDT8/G4/835XL/CVG	93135946	LED18ET8/G/4/835CVG		
41127	F32T8SPX41ECOCVG	4100K	93154589	LED16BDT8/G4/840XL/CVG	93135947	LED18ET8/G/4/840CVG		
15971	F32T8SPX50ECOCVG	5000K	93154586	LED16BDT8/G4/850XL/CVG	93135948	LED18ET8/G/4/850CVG		
94843	F32T8SPX65ECOCVG	6500K	93154586	LED16BDT8/G4/850XL/CVG	93135948	LED18ET8/G/4/850CVG		

T12 Linear Fluorescent

T12 Linear Fluorescent Medium Bi-Pin (G13)		Color Temp.	Ballast Bypass (Type B) LED Tube		Ballast Compatible (Type A) LED Tube		Remote Driver (Type C) LED Tube	
Order Code	Description		Order Code	Description	Order Code	Description	Order Code	Description
66474	F34CX41/WM/ECO	4100K	93305115	LED11BDT8/G4/840/120-347	93107392	LED11ET8/G/4/840	34235	LEDT8/LC/G/4/840
80096	F40C50/ECO	5000K	93305116	LED11BDT8/G4/850/120-347	93107393	LED11ET8/G/4/850	34239	LEDT8/LC/G/4/850
80097	F40DX/ECO	6500K	93305116	LED11BDT8/G4/850/120-347	93107393	LED11ET8/G/4/850	34239	LEDT8/LC/G/4/850
80045	F20T12/CW/ECO	4100K	93309181	LED7BDT8/G2/840/120-347	35778	LED8ET8/G/2/840	36409	LEDT8/LC/G/2/840
80047	F20T12/D/ECO	6500K	93309182	LED7BDT8/G2/850/120-347	35779	LED8ET8/G/2/850	36413	LEDT8/LC/G/2/850

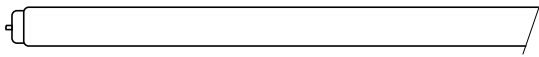

T8 (1" diameter) Single Pin Base (Fa8)

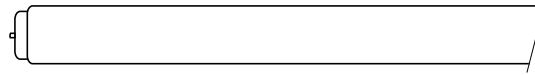

T12 (1-1/2" Diameter) Single Pin Base (Fa8)

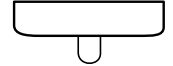

Single Pin
Fa8

T8 Linear Fluorescent

T8 Linear Fluorescent Single Pin (Fa8)		Color Temp.	Ballast Bypass (Type B) LED Tube		Ballast Compatible (Type A) LED Tube		Remote Driver (Type C) LED Tube	
Order Code	Description		Order Code	Description	Order Code	Description	Order Code	Description
68869	F96T8/XL/SPX35/2	3500K	93309184	LED42BDT8/G8/Fa8/835/120-347			62327	LED36T8/G/8/835
68870	F96T8/XL/SPX41/2	4100K	93309185	LED42BDT8/G8/Fa8/840/120-347			62329	LED36T8/G/8/840
68871	F96T8/XL/SPX50/2	5000K	93309186	LED42BDT8/G8/Fa8/850/120-347			62349	LED36T8/G/8/850
15123	F96T8/XLSPX41WMP	4100K	93309185	LED42BDT8/G8/Fa8/840/120-347			62329	LED36T8/G/8/840

T12 Linear Fluorescent

T12 Linear Fluorescent Single Pin (Fa8)		Color Temp.	Ballast Bypass (Type B) LED Tube		Ballast Compatible (Type A) LED Tube		Remote Driver (Type C) LED Tube	
Order Code	Description		Order Code	Description	Order Code	Description	Order Code	Description
68052	F96T12/CW/C/WM	4100K	93309185	LED42BDT8/G8/Fa8/840/120-347			62329	LED36T8/G/8/840
66858	F96T12XL/HL41/WM	4100K	93309185	LED42BDT8/G8/Fa8/840/120-347			62329	LED36T8/G/8/840
14652	F96T12/DX	6500K	93309186	LED42BDT8/G8/Fa8/850/120-347			62349	LED36T8/G/8/850

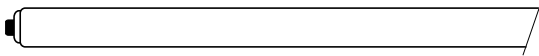

T8 (1" diameter) Recessed Double Contact Base (R17d)



T12 (1-1/2" Diameter) Recessed Double Contact Base (R17d)

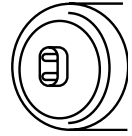

Recessed Double Contact R17d

T8 Linear Fluorescent

T8 Linear Fluorescent Recessed Double Contact (R17d)		Color Temp.	Ballast Bypass (Type B) LED Tube	
Order Code	Description		Order Code	Description
12533	F96T8/SPX35/HO	3500K	93132591	LED43BDT8/G8/835
12534	F96T8/SPX41/HO	4100K	93309189	LED42BDT8/G8/R17d/840/120-347
12535	F96T8/SPX50/HO	5000K	93309190	LED42BDT8/G8/R17d/850/120-347

T12 Linear Fluorescent

T12 Linear Fluorescent (Recessed Double Contact (R17d))		Color Temp.	Ballast Bypass (Type B) LED Tube	
Order Code	Description		Order Code	Description
10773	F48T12/CW/HO	4100K		
10778	F48T12/D/HO	6500K		
23075	F60T12/CW/HO 15PK	4100K		
23077	F60T12/D/HO 15PK	6500K		
13697	F72T12/CW/HO 15PK	4100K		
13699	F72T12/D/HO 15PK	6500K		
13766	F84T12/CW/HO 15PK	4100K		
13767	F84T12/D/HO 15PK	6500K		
66862	F96T12/HL41/HO/WM	4100K	93309189	LED42BDT8/G8/R17d/840/120-347
11918	F96T12/CW/HO/CT	4100K	93309189	LED42BDT8/G8/R17d/840/120-347
11919	F96T12/D/HO/CT	6500K	93309190	LED42BDT8/G8/R17d/850/120-347



LED Lamps - Type A Plug-ins

Type A LED plug-in lamps are direct replacements for pin-based compact fluorescent lamps. These lamps operate from CFL ballasts. Horizontal and vertical orientation lamps are offered in order to minimize energy consumption and improve fixture efficiency. Choose the lamp orientation that suits the application.





LED Lamps – Type B Plug-ins

Type B LED plug-in lamps offer the opportunity to replace pin-based compact fluorescent lamps and eliminate costs related to the ballasts. Type B lamps operate from mains voltage. The fixture is re-wired to bypass the ballast. Horizontal and vertical orientation lamps are offered in order to minimize energy consumption and improve fixture efficiency. Choose the lamp orientation that suits the application.

Type B LED plug-in lamps can be used in a variety of compact fluorescent sockets. By re-wiring the socket and eliminating concerns related to ballast compatibility, a single lamp can fit and operate in a wider variety of sockets. Type B LED plug-in lamp bases do not have exclusionary features related to specific wattages like CFL lamps do. A 2-pin G24 lamp can fit in 2-pin G24d or 4-pin G24q/GX24q sockets as shown below.

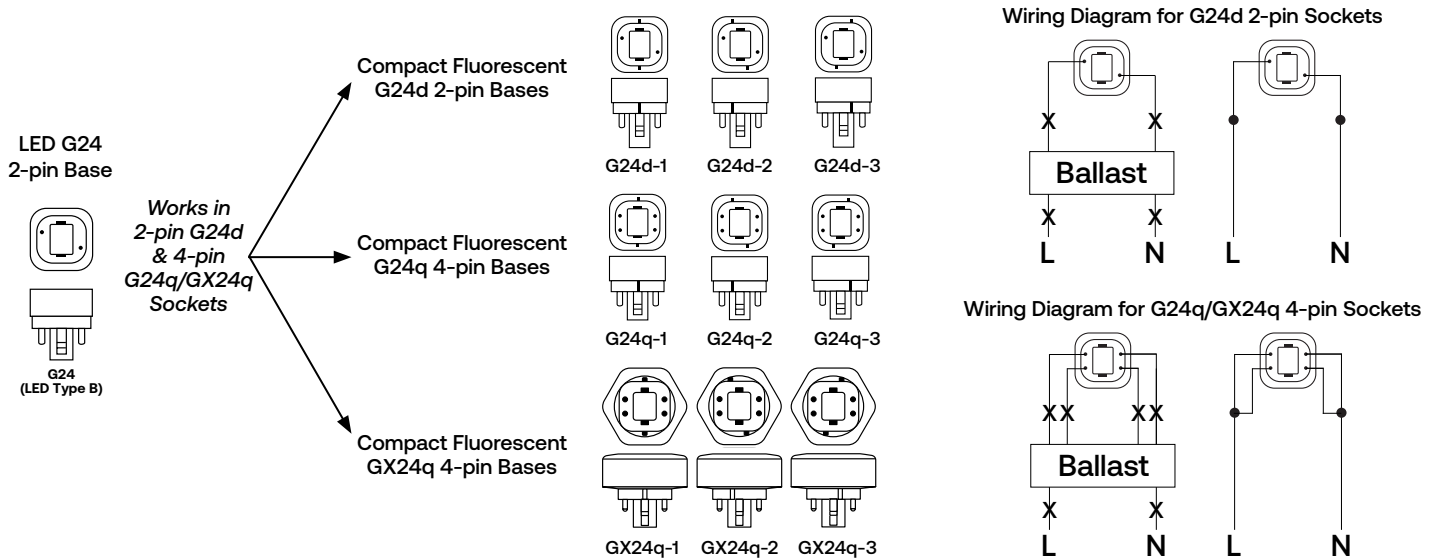

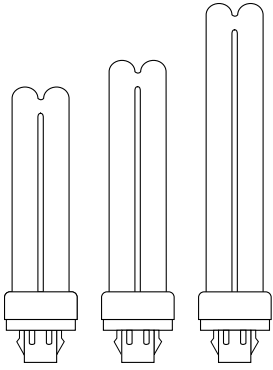

F13DBX G24q-1 F18DBX G24q-2 F26DBX G24q-3

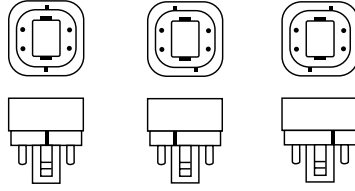

G24q-1 G24q-2 G24q-3

Double Biax® Compact Fluorescent (4-pin)

4-Pin Base: G24q-1		Color Temp.	Ballast Bypass (Type B) LED Lamp		Ballast Compatible (Type A) LED Lamp	
Order Code	Description		Order Code	Description	Order Code	Description
97594	F13DBX/827/ECO4P	2700K	93300068	LED8BG24-O/827-4PK	Vertical: 93300089	LED9G24q-V/8SC-4PK
					Horizontal: 33994	LED9G24Q-H/827
97595	F13DBX/830/ECO4P	3000K	93300069	LED8BG24-O/830-4PK	Vertical: 93300089	LED9G24q-V/8SC-4PK
					Horizontal: 33997	LED9G24Q-H/830
97596	F13DBX/835/ECO4P	3500K	93300080	LED8BG24-O/835-4PK	Vertical: 93300089	LED9G24q-V/8SC-4PK
					Horizontal: 33998	LED9G24Q-H/835
97597	F13DBX/841/ECO4P	4100K	93300081	LED8BG24-O/840-4PK	Vertical: 93300089	LED9G24q-V/8SC-4PK
					Horizontal: 33999	LED9G24Q-H/840

4-Pin Base: G24q-2		Color Temp.	Ballast Bypass (Type B) LED Lamp		Ballast Compatible (Type A) LED Lamp	
Order Code	Description		Order Code	Description	Order Code	Description
97598	F18DBX/827/ECO4P	2700K	93300082	LED10BG24-O/827-4PK	Vertical: 93300089	LED9G24q-V/8SC-4PK
					Horizontal: 33994	LED9G24Q-H/827
97599	F18DBX/830/ECO4P	3000K	93300083	LED10BG24-O/830-4PK	Vertical: 93300089	LED9G24q-V/8SC-4PK
					Horizontal: 33997	LED9G24Q-H/830
97600	F18DBX/835/ECO4P	3500K	93300084	LED10BG24-O/835-4PK	Vertical: 93300089	LED9G24q-V/8SC-4PK
					Horizontal: 33998	LED9G24Q-H/835
97601	F18DBX/841/ECO4P	4100K	93300086	LED10BG24-O/840-4PK	Vertical: 93300089	LED9G24q-V/8SC-4PK
					Horizontal: 33999	LED9G24Q-H/840

4-Pin Base: G24q-3		Color Temp.	Ballast Bypass (Type B) LED Lamp		Ballast Compatible (Type A) LED Lamp	
Order Code	Description		Order Code	Description	Order Code	Description
97610	F26DBX/827/ECO4P	2700K	Vertical: 93300088	LED11BG24-V/8SC/120-347-4PK	Vertical: 93300089	LED9G24q-V/8SC-4PK
			Horizontal: 93300087	LED11BG24-H/8SC/120-347-4PK	Horizontal: 33994	LED9G24Q-H/827
97611	F26DBX/830/ECO4P	3000K	Vertical: 93300088	LED11BG24-V/8SC/120-347-4PK	Vertical: 93300089	LED9G24q-V/8SC-4PK
			Horizontal: 93300087	LED11BG24-H/8SC/120-347-4PK	Horizontal: 33997	LED9G24Q-H/830
97612	F26DBX/835/ECO4P	3500K	Vertical: 93300088	LED11BG24-V/8SC/120-347-4PK	Vertical: 93300089	LED9G24q-V/8SC-4PK
			Horizontal: 93300087	LED11BG24-H/8SC/120-347-4PK	Horizontal: 33998	LED9G24Q-H/835
97613	F26DBX/841/ECO4P	4100K	Vertical: 93300088	LED11BG24-V/8SC/120-347-4PK	Vertical: 93300089	LED9G24q-V/8SC-4PK
			Horizontal: 93300087	LED11BG24-H/8SC/120-347-4PK	Horizontal: 33999	LED9G24Q-H/840

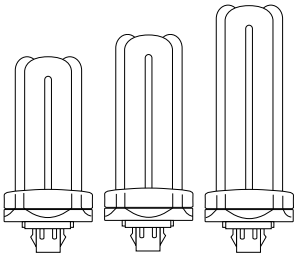

F26TBX F32TBX F42TBX
GX24q-3 GX24q-3 GX24q-4

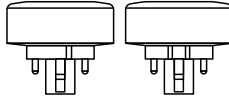
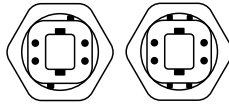

GX24q-3 GX24q-4

Triple Biax® Compact Fluorescent (4-pin)

4-Pin Base: GX24q-3		Color Temp.	Ballast Bypass (Type B) LED Lamp		Ballast Compatible (Type A) LED Lamp	
Order Code	Description		Order Code	Description	Order Code	Description
97614	F26TBX/827/A/ECO	2700K	Vertical: 93300088	LED11BG24-V/8SC/120-347-4PK	Vertical: 93300089	LED9G24q-V/8SC-4PK
			Horizontal: 93300087	LED11BG24-H/8SC/120-347-4PK	Horizontal: 33994	LED9G24Q-H/827
97615	F26TBX/830/A/ECO	3000K	Vertical: 93300088	LED11BG24-V/8SC/120-347-4PK	Vertical: 93300089	LED9G24q-V/8SC-4PK
			Horizontal: 93300087	LED11BG24-H/8SC/120-347-4PK	Horizontal: 33997	LED9G24Q-H/830
97616	F26TBX/835/A/ECO	3500K	Vertical: 93300088	LED11BG24-V/8SC/120-347-4PK	Vertical: 93300089	LED9G24q-V/8SC-4PK
			Horizontal: 93300087	LED11BG24-H/8SC/120-347-4PK	Horizontal: 33998	LED9G24Q-H/835
97617	F26TBX/841/A/ECO	4100K	Vertical: 93300088	LED11BG24-V/8SC/120-347-4PK	Vertical: 93300089	LED9G24q-V/8SC-4PK
			Horizontal: 93300087	LED11BG24-H/8SC/120-347-4PK	Horizontal: 33999	LED9G24Q-H/840
97629	F32TBX/827/A/ECO	2700K	Vertical: 93312489	LED18BG24-V/8SC/120-347	Vertical: 39288	LED19GX24q-V/827
			Horizontal: 93312525	LED18BG24-H/8SC/120-347	Horizontal: 39289	LED19GX24q-H/827
97630	F32TBX/830/A/ECO	3000K	Vertical: 93312489	LED18BG24-V/8SC/120-347	Vertical: 39277	LED19GX24q-V/830
			Horizontal: 93312525	LED18BG24-H/8SC/120-347	Horizontal: 39282	LED19GX24q-H/830
97631	F32TBX/835/A/ECO	3500K	Vertical: 93312489	LED18BG24-V/8SC/120-347	Vertical: 39275	LED19GX24q-V/835
			Horizontal: 93312525	LED18BG24-H/8SC/120-347	Horizontal: 39276	LED19GX24q-H/835
97632	F32TBX/841/A/ECO	4100K	Vertical: 93312489	LED18BG24-V/8SC/120-347	Vertical: 39279	LED19GX24q-V/840
			Horizontal: 93312525	LED18BG24-H/8SC/120-347	Horizontal: 39283	LED19GX24q-H/840

Base: GX24q-4		Color Temp.	Ballast Bypass (Type B) LED Lamp		Ballast Compatible (Type A) LED Lamp	
Order Code	Description		Order Code	Description	Order Code	Description
97633	F42TBX/827/A/ECO	2700K	Vertical: 93312489	LED18BG24-V/8SC/120-347	Vertical: 39288	LED19GX24q-V/827
			Horizontal: 93312525	LED18BG24-H/8SC/120-347	Horizontal: 39289	LED19GX24q-H/827
97634	F42TBX/830/A/ECO	3000K	Vertical: 93312489	LED18BG24-V/8SC/120-347	Vertical: 39277	LED19GX24q-V/830
			Horizontal: 93312525	LED18BG24-H/8SC/120-347	Horizontal: 39282	LED19GX24q-H/830
97635	F42TBX/835/A/ECO	3500K	Vertical: 93312489	LED18BG24-V/8SC/120-347	Vertical: 39275	LED19GX24q-V/835
			Horizontal: 93312525	LED18BG24-H/8SC/120-347	Horizontal: 39276	LED19GX24q-H/835
97636	F42TBX/841/A/ECO	4100K	Vertical: 93312489	LED18BG24-V/8SC/120-347	Vertical: 39279	LED19GX24q-V/840
			Horizontal: 93312525	LED18BG24-H/8SC/120-347	Horizontal: 39283	LED19GX24q-H/840

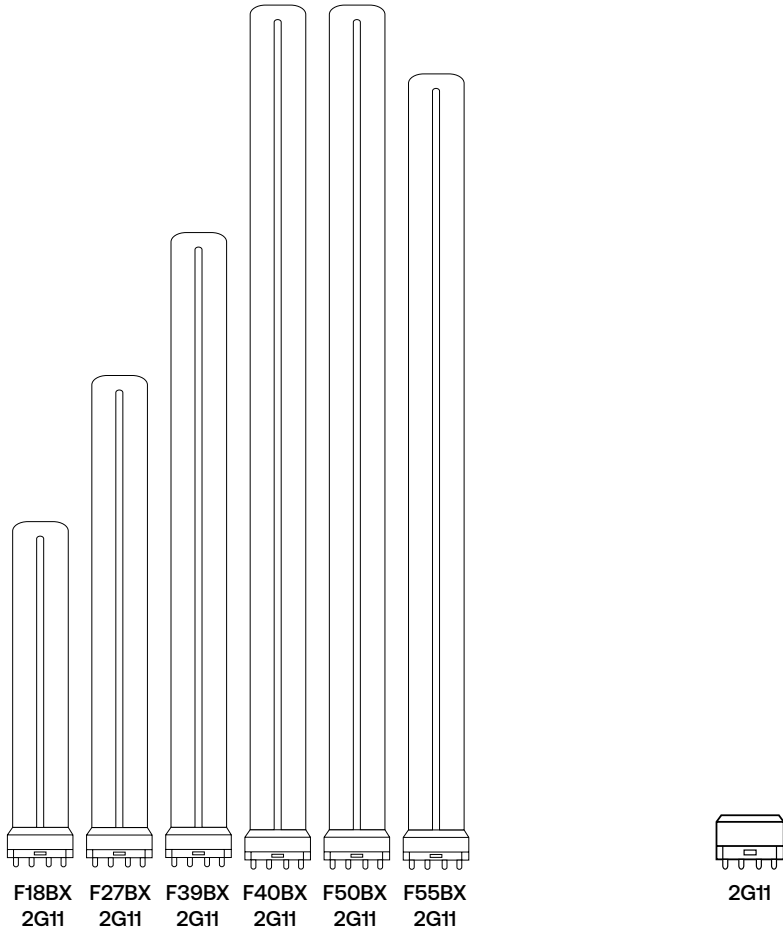

High Lumen Biax® Compact Fluorescent (4-pin)

4-Pin Base: 2G11		Color Temp.	Ballast Bypass (Type B) LED Lamp		Ballast Compatible (Type A) LED Lamp	
Order Code	Description		Order Code	Description	Order Code	Description
16053	F18BX/SPX35 10PK	3500K				
16940	F18BX/SPX41 10PK	4100K				
28393	F39BXSPX35RS10PK	3500K				
28458	F39BXSPX41RS10PK	4100K				
75400	F40/25BX/835/IS/WM	3500K	93136086	LED17B2G11/835	39074	LED172G11/835/10
16953	F40/30BX/SPX30	3000K	93136025	LED17B2G11/830	39073	LED172G11/830/10
16648	F40/30BX/SPX35	3500K	93136086	LED17B2G11/835	39074	LED172G11/835/10
16954	F40/30BX/SPX41	4100K	93136087	LED17B2G11/840	39075	LED172G11/840/10
31952	F55BX/835	3500K				
31953	F55BX/840	4100K				

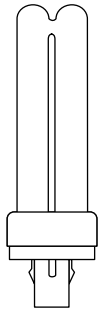

F13DBX
GX23-2

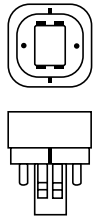

GX23-2

Double Biax® Compact Fluorescent (2-pin)

2-Pin Base: GX23-2		Color Temp.	Ballast Bypass (Type B) LED Lamp	
Order Code	Description		Order Code	Description
97586	F13DBX23/827/ECO	2700K	93312531	LED8BGX23-2-O/827
97588	F13DBX23/835/ECO	3500K	93312543	LED8BGX23-2-O/835
97589	F13DBX23/841/ECO	4100K	93312549	LED8BGX23-2-O/840

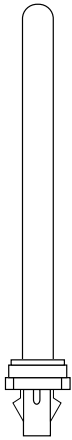

F13BX
GX23



GX23

Low Watt Biax® Compact Fluorescent (2-pin)

2-Pin Base: GX23		Color Temp.	Ballast Bypass (Type B) LED Lamp		Ballast Compatible (Type A) LED Lamp	
Order Code	Description		Order Code	Description	Order Code	Description
97573	F13BX/827/ECO	2700K	93312495	LED5BGX23/827	91404	LED5GX23/827
97569	F13BX/835/ECO	3500K	93312507	LED5BGX23/835	91407	LED5GX23/835
97571	F13BX/841/ECO	4100K	93312513	LED5BGX23/840	91408	LED5GX23/840

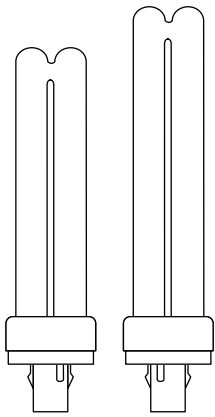

F18DBX
G24d-2 F26DBX
G24d-3

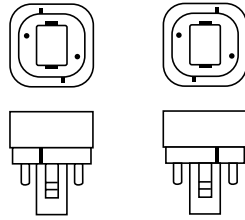

G24d-2 G24d-3

Double Biax® Compact Fluorescent (2-pin)

2-Pin Base: G24d-2		Color Temp.	Ballast Bypass (Type B) LED Lamp		Ballast Compatible (Type A) LED Lamp	
Order Code	Description		Order Code	Description	Order Code	Description
97577	F18DBX/827/ECO	2700K	Vertical: 93300088	LED11BG24-V/8SC/120-347-4PK	Vertical: 93300091	LED11G24d-V/8SC-4PK
			Horizontal: 93300087	LED11BG24-H/8SC/120-347-4PK	Horizontal: 93300090	LED11G24d-H/8SC-4PK
97579	F18DBX/835/ECO	3500K	Vertical: 93300088	LED11BG24-V/8SC/120-347-4PK	Vertical: 93300091	LED11G24d-V/8SC-4PK
			Horizontal: 93300087	LED11BG24-H/8SC/120-347-4PK	Horizontal: 93300090	LED11G24d-H/8SC-4PK
97580	F18DBX/841/ECO	4100K	Vertical: 93300088	LED11BG24-V/8SC/120-347-4PK	Vertical: 93300091	LED11G24d-V/8SC-4PK
			Horizontal: 93300087	LED11BG24-H/8SC/120-347-4PK	Horizontal: 93300090	LED11G24d-H/8SC-4PK

2-Pin Base: G24d-3		Color Temp.	Ballast Bypass (Type B) LED Lamp		Ballast Compatible (Type A) LED Lamp	
Order Code	Description		Order Code	Description	Order Code	Description
97606	F26DBX/827/ECO	2700K	Vertical: 93300088	LED11BG24-V/8SC/120-347-4PK	Vertical: 93300091	LED11G24d-V/8SC-4PK
			Horizontal: 93300087	LED11BG24-H/8SC/120-347-4PK	Horizontal: 93300090	LED11G24d-H/8SC-4PK
97608	F26DBX/835/ECO	3500K	Vertical: 93300088	LED11BG24-V/8SC/120-347-4PK	Vertical: 93300091	LED11G24d-V/8SC-4PK
			Horizontal: 93300087	LED11BG24-H/8SC/120-347-4PK	Horizontal: 93300090	LED11G24d-H/8SC-4PK
97609	F26DBX/841/ECO	4100K	Vertical: 93300088	LED11BG24-V/8SC/120-347-4PK	Vertical: 93300091	LED11G24d-V/8SC-4PK
			Horizontal: 93300087	LED11BG24-H/8SC/120-347-4PK	Horizontal: 93300090	LED11G24d-H/8SC-4PK



LED Lamps – Type B HID

GE LED Lamps that replace traditional HID lamps are all Type B, which means the fixture is re-wired to bypass the ballast. Type B LED HID lamps offer a lower wattage and longer life alternative to traditional HID technology, and eliminate costs related to the ballasts. GE LED Lamps feature omnidirectional light output, with similar light distribution to traditional HID lamps. GE LED Lamps also adhere to the ANSI length and diameter of traditional HID bulb shapes, ensuring that the lamps will fit into fixtures and effectively utilize existing optics. Active cooling (with fans built into the lamps) is utilized to achieve very high output from compact lamps. NEMA Standard LL 10-2020 provides guidance for LED HID wattage equivalency claims.

Lamp Drawings (not drawn to scale)

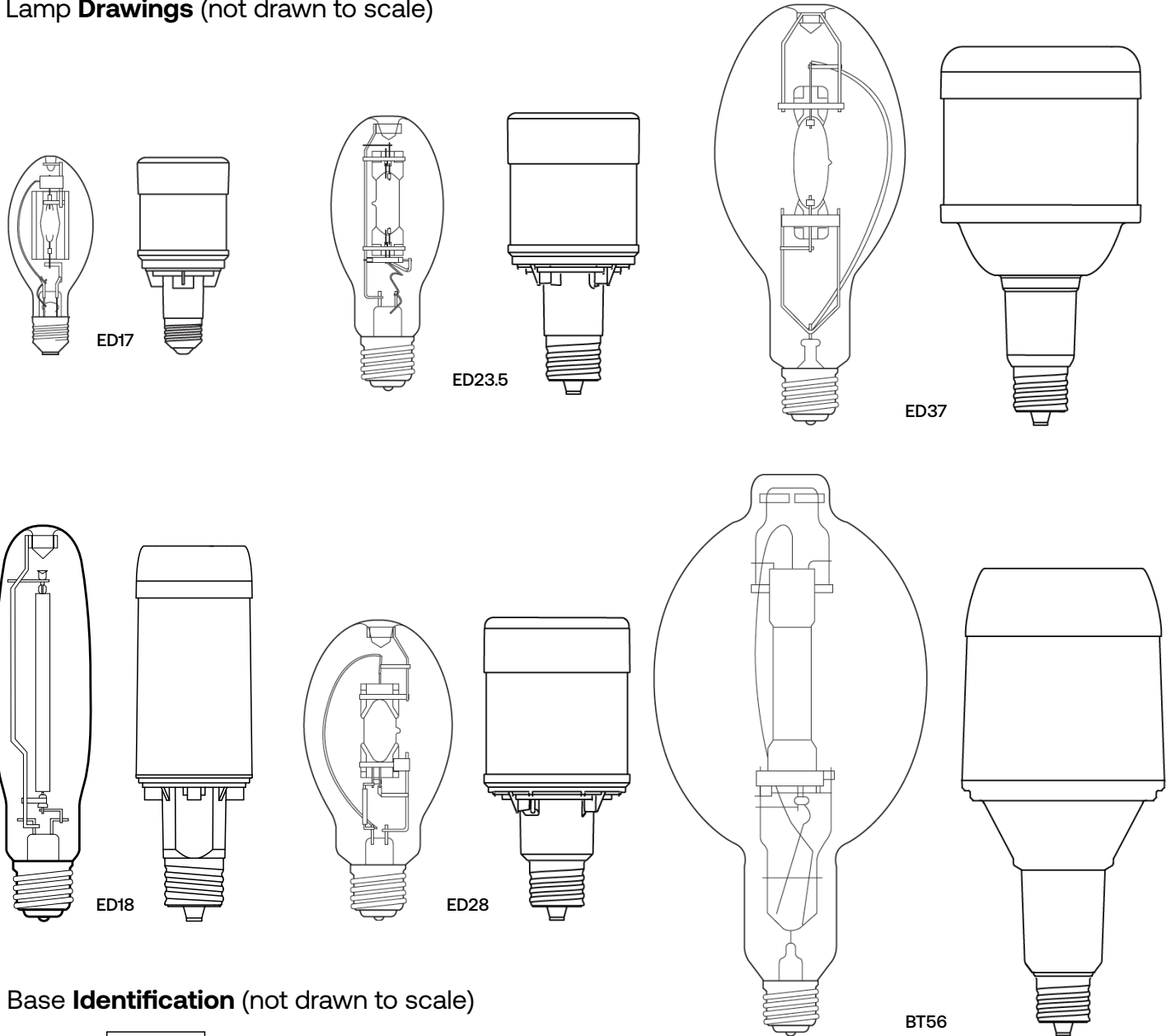

Base Identification (not drawn to scale)





NEMA LED HID Wattage Equivalency

In February of 2021, the National Electrical Manufacturers Association (NEMA) published NEMA LL 10-2020 *Replacing HID Lamps with LED Lamps: Light Output Equivalency Claims*. Current uses this Standard for LED products replacing HID lamps, meeting or exceeding the minimum LED light output for equivalency claims. The LED wattage equivalency varies based on the type of HID lamp being replaced - Metal Halide (MH) or High Pressure Sodium (HPS).

Metal Halide Lamp Wattage (W)	Metal Halide Initial Light Output (lm)	Minimum LED Lamp Initial Light Output (lm)	Current LED Ordinary Location Retrofit Lamps Active Cooling	Current LED Selectable Ordinary Location Retrofit Lamps Active Cooling	Current LED Selectable Ordinary Location Retrofit Lamps Passive Cooling	Current LED Hazardous Location Retrofit Lamps Active Cooling
50	3,200	2,000	LED21ED17	LED/LC/ED17		LED21ED17/HAZ
70	5,200	3,000	LED21ED17	LED/LC/ED17		LED21ED17/HAZ
100	8,100	5,000	LED35ED17; LED45ED17	LED/LC/ED17		LED35ED17/HAZ; LED45ED17/HAZ
150	12,000	7,500	LED50ED23.5	LED/LC/ED23.5	LED/LC/ED23.5P	
175	11,000	7,000	LED45ED17; LED50ED23.5	LED/LC/ED17; LED/LC/ED23.5	LED/LC/ED23.5P	
250	19,100	12,000	LED80ED23.5	LED/LC/ED23.5		LED80ED23.5/HAZ
320	25,600	16,500	LED115ED28	LED/LC/ED28		
350	28,400	18,000	LED115ED28	LED/LC/ED28		
360	29,400	19,000	LED150ED28	LED/LC/ED28		LED150ED28/HAZ
400	33,100	21,500	LED150ED28; LED180ED18	LED/LC/ED28; LED/LC/ED37		LED150ED28/HAZ
750	72,300	46,500	LED360ED37	LED/LC/ED37		
1,000	100,280	65,000	LED450BT56; LED470BT56	LED/LC/ED37		

HPS Lamp Wattage (W)	HPS Initial Light Output (lm)	Minimum LED Lamp Initial Light Output (lm)	Current LED Ordinary Location Retrofit Lamps Active Cooling	Current LED Selectable Ordinary Location Retrofit Lamps Active Cooling	Current LED Selectable Ordinary Location Retrofit Lamps Passive Cooling	Current LED Hazardous Location Retrofit Lamps Active Cooling
50	4,500	2,500	LED21ED17	LED/LC/ED17		LED21ED17/HAZ
70	6,300	4,000	LED35ED17	LED/LC/ED17		LED35ED17/HAZ
100	9,500	6,000	LED45ED17; LED50ED23.5	LED/LC/ED17; LED/LC/ED23.5	LED/LC/ED23.5P	LED45ED17/HAZ
150	13,000	8,500	LED80ED23.5	LED/LC/ED23.5		LED80ED23.5/HAZ
200	19,500	12,500		LED/LC/ED23.5		
250	26,000	17,000	LED115ED28	LED/LC/ED28		
310	33,200	21,500	LED150ED28	LED/LC/ED28		LED150ED28/HAZ
400	44,000	29,000	LED180ED18; LED270BT56	LED/LC/ED37		
600	66,000	42,500	LED360ED37	LED/LC/ED37		
750	82,500	53,500	LED450BT56	LED/LC/ED37		
1,000	110,000	73,000	LED470BT56			

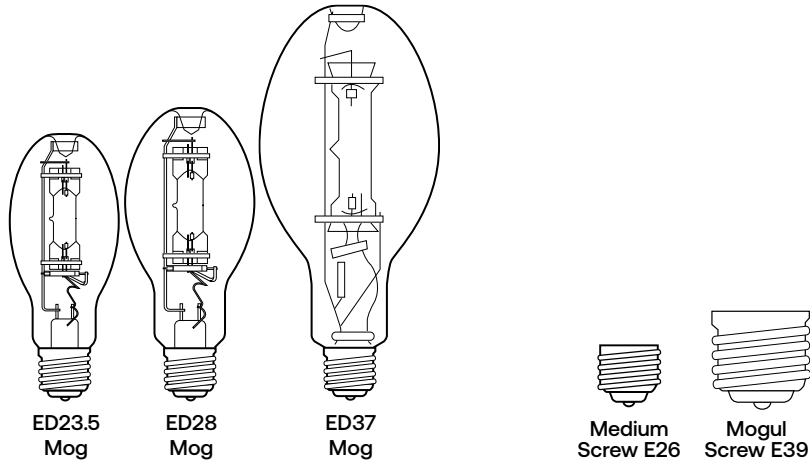

Mercury Vapor Lamps

Mercury HID Lamps 100-400 Watts					Ballast Bypass (Type B) LED HID Ordinary Location Active Cooling		Ballast Bypass (Type B) LED HID Ordinary Location Selectable Active Cooling		Ballast Bypass (Type B) LED HID Ordinary Location Selectable Passive Cooling	
Order Code	Description	Bulb Shape	Lamp Base	Color Temp.	Order Code	Description	Order Code	Description	Order Code	Description
22575	HR100DX38	ED23.5	E39	3900K	22679	LED50ED23.5/740	93314526	LED/LC/ED17/7SC/120-347	93314601	LED/LC/ED23.5P/7SC
24062	HR175DX39	ED23.5	E39	3900K	22679	LED50ED23.5/740	93312106	LED/LC/ED23.5/7SC	93314601	LED/LC/ED23.5P/7SC
32127	HR250DX37	ED28	E39	3900K	22635	LED80ED23.5/740	93312106	LED/LC/ED23.5/7SC	TBD	LED/LC/ED28P/7SC
23998	HR400DX33	ED37	E39	3900K	22611	LED150ED28/740	93312102	LED/LC/ED28/7SC		

End users may choose from a variety of output levels and color temperatures when converting to LED. Lamps certified for use in hazardous locations are also available. Please see the LED HID Spec Sheets or the GE Lamps Catalog for the full list of LED Lamp options.

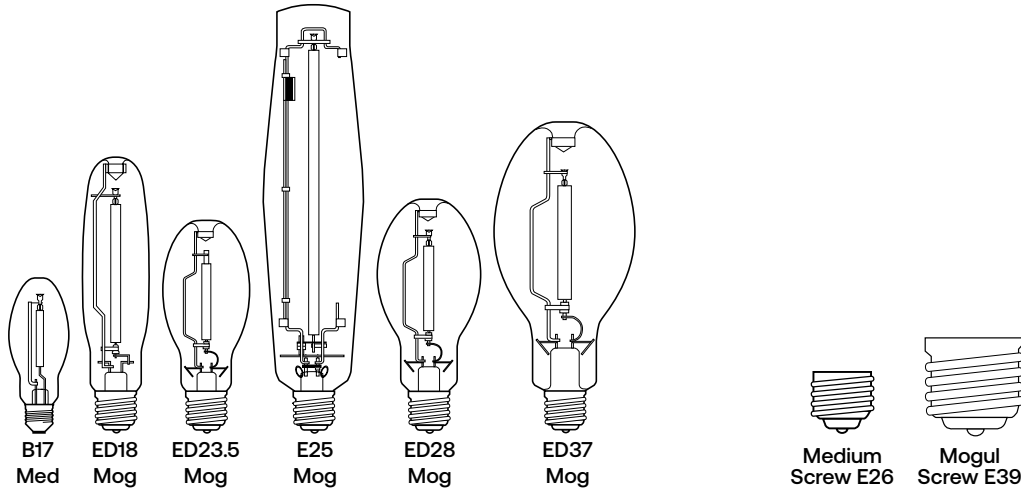

High Pressure Sodium Lamps

HPS HID Lamps 70-1000 Watts					Ballast Bypass (Type B) LED HID Ordinary Location Active Cooling		Ballast Bypass (Type B) LED HID Ordinary Location Selectable Active Cooling		Ballast Bypass (Type B) LED HID Ordinary Location Selectable Passive Cooling	
Order Code	Description	Bulb Shape	Lamp Base	Color Temp.	Order Code	Description	Order Code	Description	Order Code	Description
11339	LU70/MED/ECO	B17	E26	1900K	93112114	LED35ED17/730	93314526	LED/LC/ED17/7SC/120-347	93316026	LED/LC/ED17P/7SC/120-347
85368	LU70/H/ECO	ED23.5	E39	1900K	22679	LED50ED23.5/740	93314526	LED/LC/ED17/7SC/120-347	93314601	LED/LC/ED23.5P/7SC
13250	LU100/MED/ECO	B17	E26	2000K	93148082	LED45ED17/740	93314526	LED/LC/ED17/7SC/120-347		
85369	LU100/H/ECO	ED23.5	E39	2000K	22679	LED50ED23.5/740	93314526	LED/LC/ED17/7SC/120-347	93314601	LED/LC/ED23.5P/7SC
13252	LU150/MED/ECO	B17	E26	2000K	93148082	LED45ED17/740	93314526	LED/LC/ED17/7SC/120-347		
85371	LU150/55/H/ECO	ED23.5	E39	2000K	93112196	LED80ED23.5/730	93312106	LED/LC/ED23.5/7SC		
85372	LU200/H/ECO	ED18	E39	2100K	93312096	LED180ED18/730				
85377	LU250/H/ECO	ED18	E39	2100K	93312096	LED180ED18/730				
85379	LU400/H/ECO	ED18	E39	2100K	93312096	LED180ED18/730				
44058	LU1000/ECO	E25	E39	2100K						

End users may choose from a variety of output levels and color temperatures when converting to LED. Lamps certified for use in hazardous locations are also available. Please see the LED HID Spec Sheets or the GE Lamps Catalog for the full list of LED Lamp options.

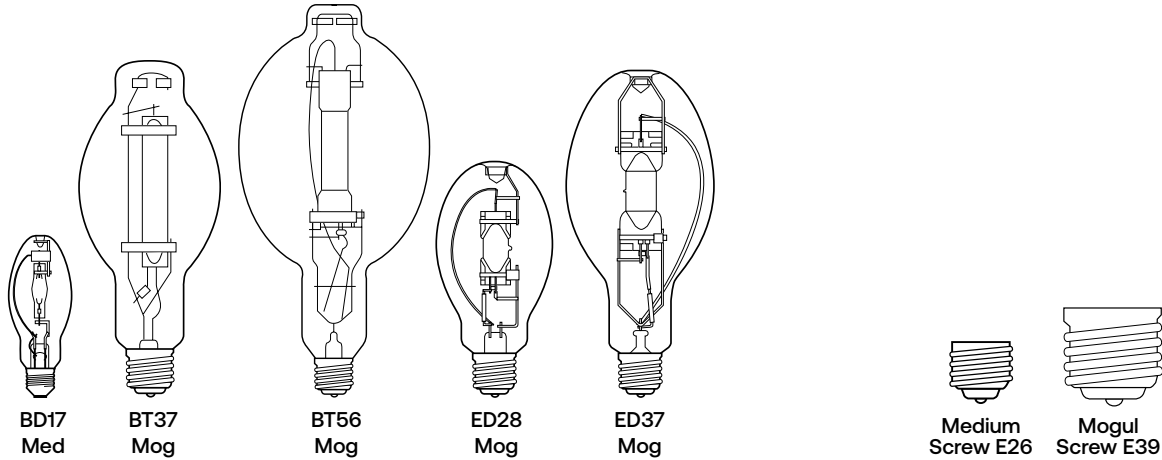

Multi-Vapor Metal Halide Lamps

MH HID Lamps 50-1500 Watts					Ballast Bypass (Type B) LED HID Ordinary Location Active Cooling		Ballast Bypass (Type B) LED HID Ordinary Location Selectable Active Cooling		Ballast Bypass (Type B) LED HID Ordinary Location Selectable Passive Cooling	
Order Code	Description	Bulb Shape	Lamp Base	Color Temp.	Order Code	Description	Order Code	Description	Order Code	Description
10361	MXR50/U/MED	BD17	E26	3700K	27729	LED21ED17/740	93314526	LED/LC/ED17/7SC/120-347	93316026	LED/LC/ED17P/7SC/120-347
22158	MXR70/U/MED	BD17	E26	3500K	27729	LED21ED17/740	93314526	LED/LC/ED17/7SC/120-347	93316026	LED/LC/ED17P/7SC/120-347
12590	MVR70/U/MED	BD17	E26	4000K	27729	LED21ED17/740	93314526	LED/LC/ED17/7SC/120-347	93316026	LED/LC/ED17P/7SC/120-347
12377	MXR70/U/MED/O	ED17	E26	3200K	27729	LED21ED17/740	93314526	LED/LC/ED17/7SC/120-347	93316026	LED/LC/ED17P/7SC/120-347
18680	MXR100/U/MED	BD17	E26	3200K	93112114	LED35ED17/730	93314526	LED/LC/ED17/7SC/120-347		
12652	MVR100/U/MED	BD17	E26	4000K	27602	LED35ED17/740	93314526	LED/LC/ED17/7SC/120-347		
12381	MXR100/U/MED/O	ED17	E26	3200K	93112114	LED35ED17/730	93314526	LED/LC/ED17/7SC/120-347		
12598	MVR150/U/MED	BD17	E26	4300K	93148082	LED45ED17/740	93314526	LED/LC/ED17/7SC/120-347		
45683	MXR150/U/MED/O	ED17	E26	3500K	93148082	LED45ED17/740	93314526	LED/LC/ED17/7SC/120-347		
18902	MVR175/U/MED	BD17	E26	4000K	93148082	LED45ED17/740	93314526	LED/LC/ED17/7SC/120-347		
47760	MVR175/U	ED28	E39	4000K	22679	LED50ED23.5/740	93312106	LED/LC/ED23.5/7SC	93314601	LED/LC/ED23.5P/7SC
47761	MVR175/C/U	ED28	E39	3900K	22679	LED50ED23.5/740	93312106	LED/LC/ED23.5/7SC	93314601	LED/LC/ED23.5P/7SC
42729	MVR250/U	ED28	E39	4200K	22635	LED80ED23.5/740	93312106	LED/LC/ED23.5/7SC	TBD	LED/LC/ED28P/7SC
78665	MVR250/U/PA	ED28	E39	3900K	22635	LED80ED23.5/740	93312106	LED/LC/ED23.5/7SC	TBD	LED/LC/ED28P/7SC
27501	MVR320/VBU/HO/PA	ED28	E39	4000K	22622	LED115ED28/740	93312102	LED/LC/ED28/7SC		
46275	MPR320/VBU/XHOPA	ED37	EX39	4000K	22622	LED115ED28/740	93312102	LED/LC/ED28/7SC		
19609	MPR320/C/PA/ED28	ED28	EX39	3700K	22622	LED115ED28/740	93312102	LED/LC/ED28/7SC		
18904	MVR400/U/ED28	ED28	E39	4000K	22611	LED150ED28/740	93312102	LED/LC/ED28/7SC		
78666	MVR400/U/PA	ED37	E39	4000K	22611	LED150ED28/740	93312102	LED/LC/ED28/7SC		
46271	MVR400/VBUED28PA	ED28	E39	4000K	22611	LED150ED28/740	93312102	LED/LC/ED28/7SC		
72885	MVR400/HOR/ED28/PA	ED28	E39	4100K	22611	LED150ED28/740	93312102	LED/LC/ED28/7SC		
46273	MPR400/VBU/XHOPA	ED37	EX39	4000K	22611	LED150ED28/740	93312102	LED/LC/ED28/7SC		
18708	MPR400/VBU/HO/O	ED37	EX39	3400K	22611	LED150ED28/740	93312102	LED/LC/ED28/7SC		
18205	MVR1000/U/BT37	BT37	E39	3700K	93122144	LED360ED37/740	93311586	LED/LC/ED37/740		
41433	MPR1000/VBU/HO/O	BT56	EX39	3500K	93096445	LED450BT56/740	93311586	LED/LC/ED37/740		
47326	MVR1500/U/SPORTS	BT56	E39	4000K	93303389	LED470BT56/740				

End users may choose from a variety of output levels and color temperatures when converting to LED. Lamps certified for use in hazardous locations are also available. Please see the LED HID Spec Sheets or the GE Lamps Catalog for the full list of LED Lamp options.