

Current 

AIRA

Open Center Luminaire

LITECONTROL
making light work™

The details are not the details.
They make the design.

—Eames

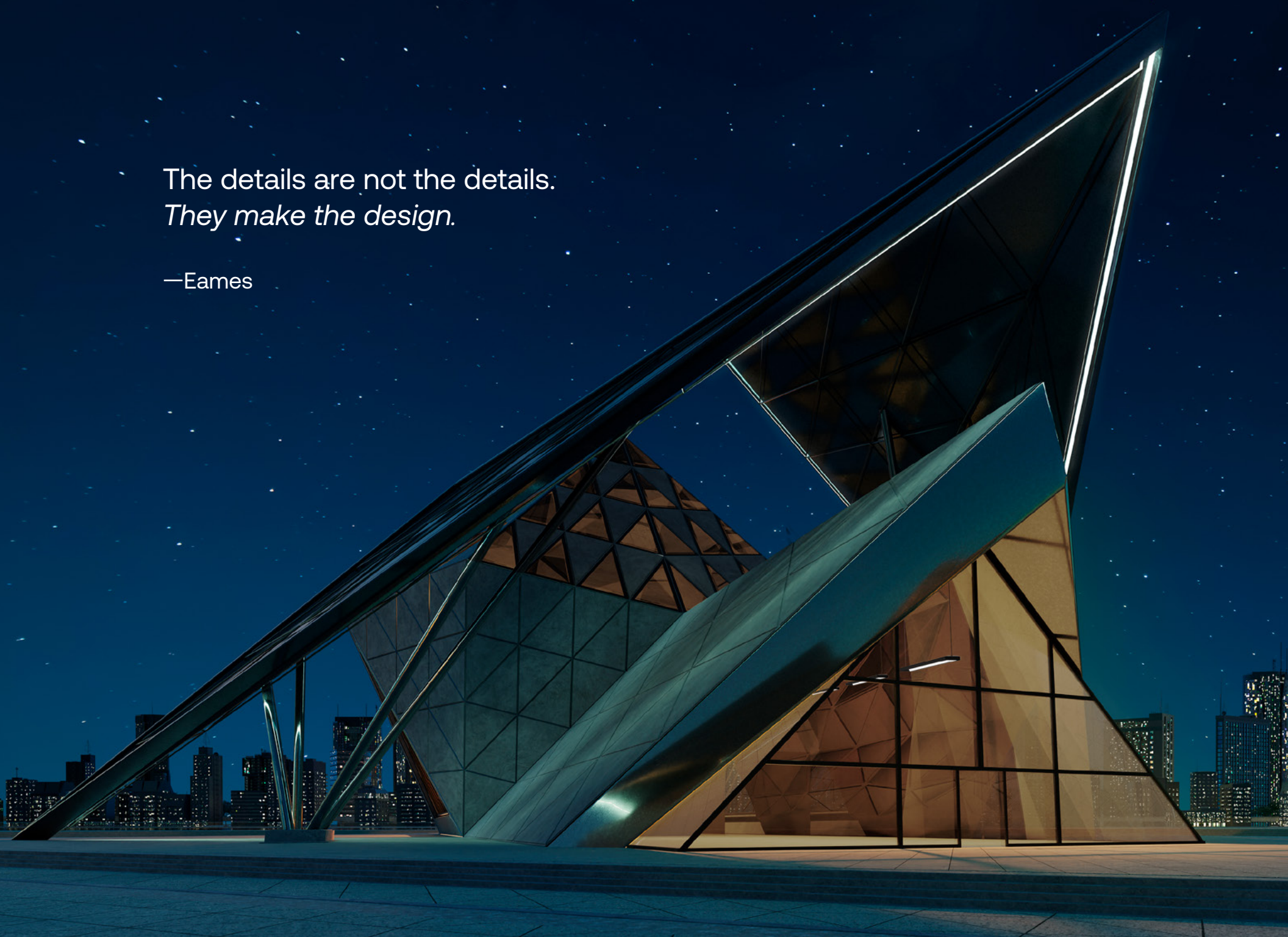



Aira



Traditional Plank

vs.



SCALE

Without Weight

Lights overhead provide a false ceiling plane, the perceived weight of which can enclose the space.

Aira's open center construction, especially when used in high ceiling applications, allows this secondary ceiling plane to feel less heavy and therefore, unquestionably more elegant.

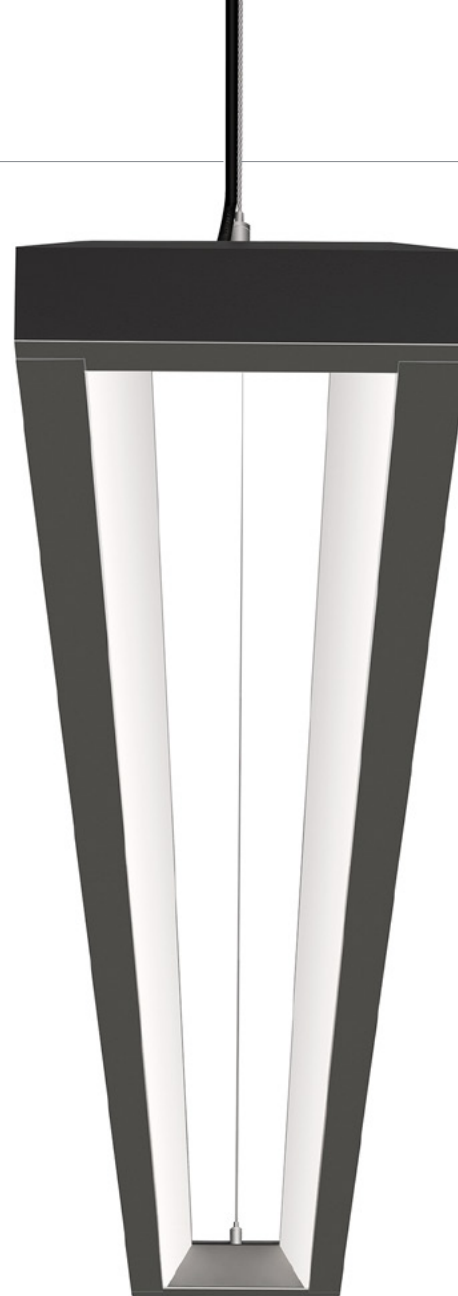





“Form and function should be one,
joined in a spiritual union.”

— Frank Lloyd Wright

Ease of installation promotes quality of installation.
Drivers, emergency batteries, and controls are all on-board
to promote contractor-friendly installation.

Aira delivers a semi-direct (25/75) distribution, designed primarily for open ceilings but appropriate for a range of applications.

A complementary wall-mount fixture shares design language and performance with the pendant while meeting ADA requirements.





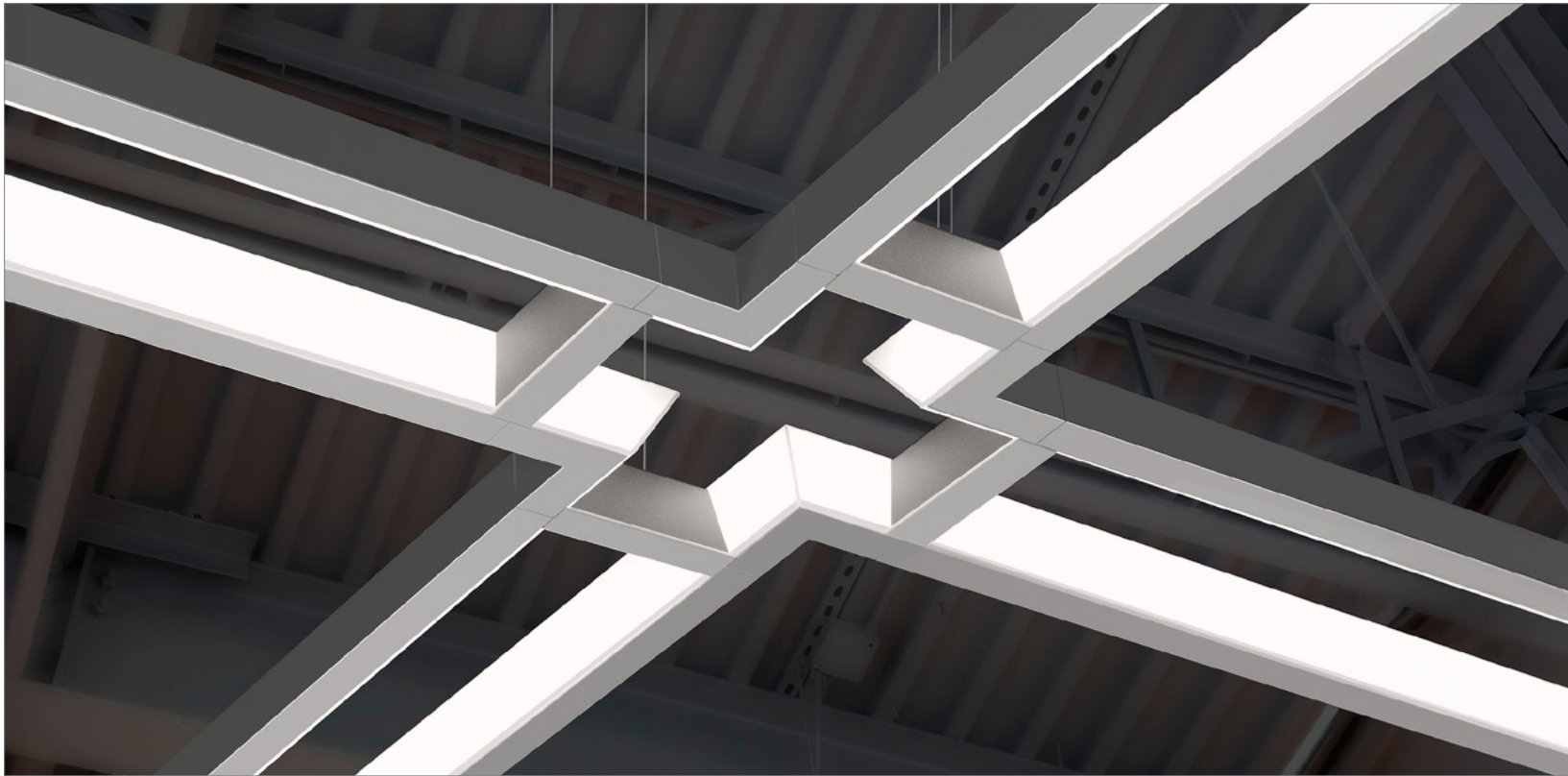

Define
your Space

Space definition allows one to interpret the environment. Aira's luminous, open-center system connectors enable this definition without sacrificing the spirit of the luminaire.

The flexibility your environment demands, executed with the thoughtfulness Aira demands.





Elegant from all Angles

Subtle details define the architectural environment, and subtle details define Aira as well. A clean read of brightness at the leading edge of the extruded rail provides definition. A design detail that helps define the fixture, and therefore your space, as exceptional.

Viewing life from all angles provides a confidence, an understanding. Viewing Aira from all angles provides the same.

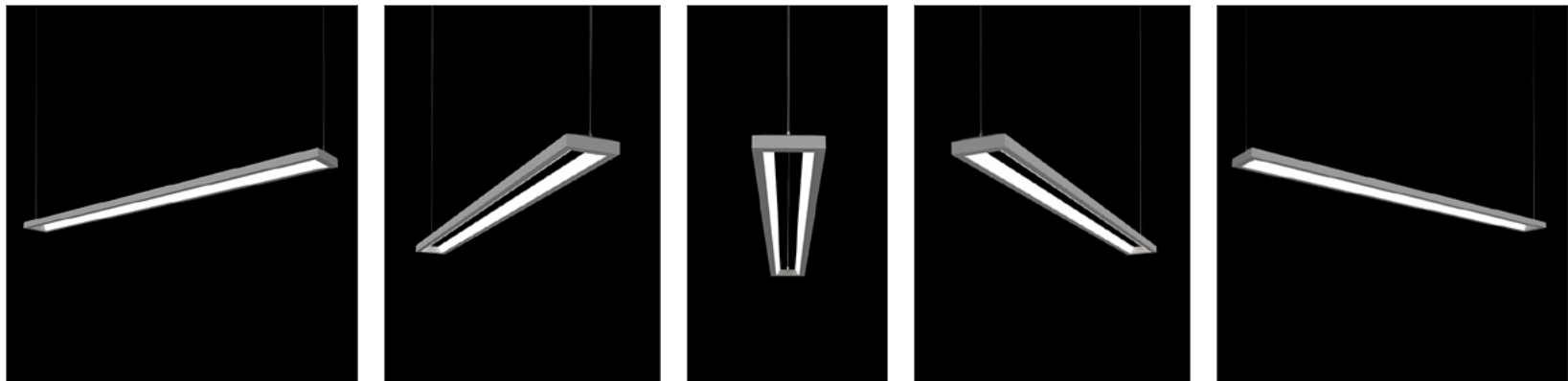



OFFICE



Seemingly Seamless

Separate elements join together to form a tight union, focused on a singular purpose.

Aira is designed to appear as a single, coherent piece. Row joins, consistent angles, & material thicknesses; all designed with intention.

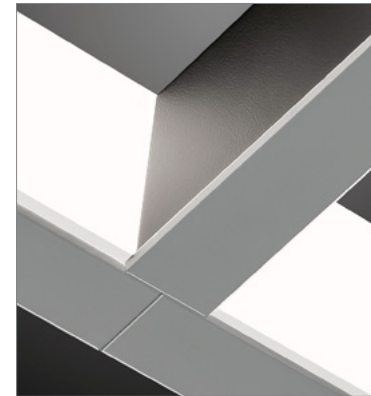



Complement your Palette

Aira cross bar inserts can be customized to complement your architectural vision.

Additionally, Kurt Versen finishes are standard options to allow seamless integration of point source and linear lighting solutions.

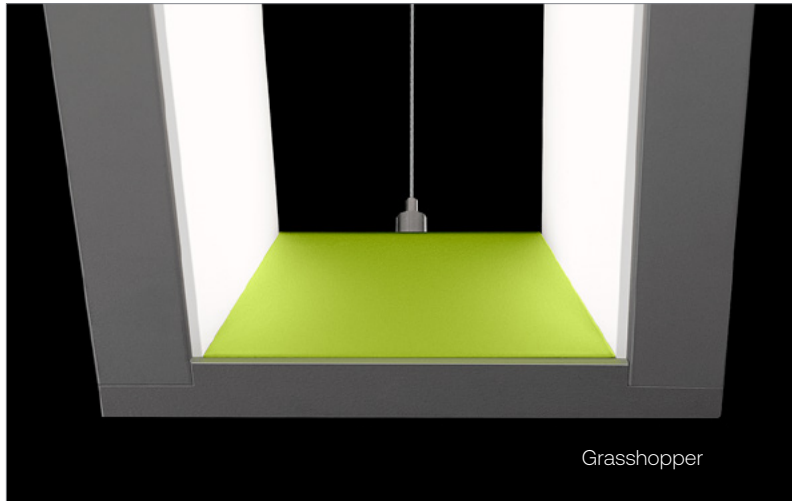

Copper

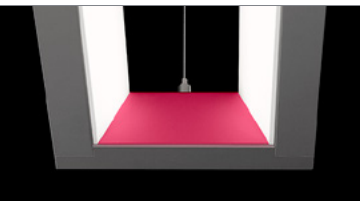

Pink Panache

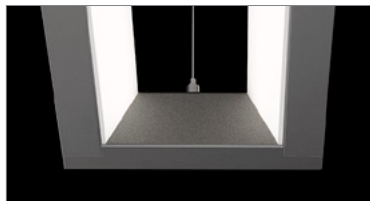

Graphite



Black Textured

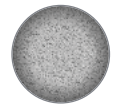

Gray Textured



Gray Smooth



Black Smooth

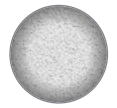

White Textured



White Smooth



Custom Color



Performance

At comparable spacing, Aira's performance results in a 10% LPD reduction while delivering significant improvement in workplane uniformity vs. a traditional plank luminaire.

Additionally, comparable lighting performance can be achieved with a reduction in rows, resulting in reduced installation costs (not shown).

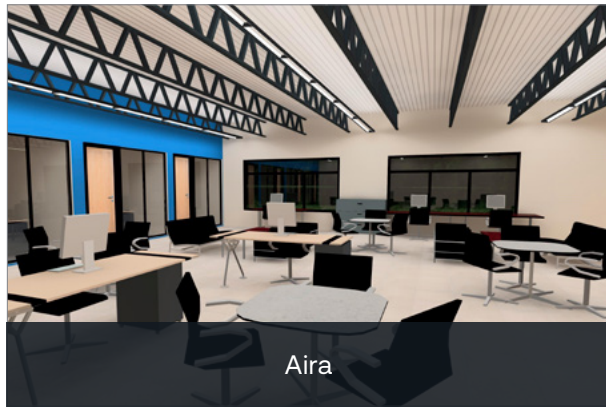

Aira

Room Size	45' x 45'
Ceiling Height	12'
Fixture AFF	9'
Workplane Target	35 FC
Max LPD	.50



Traditional Plank

Fixture Spacing: 16'

Distribution	25/75
Output	800 Lm/Ft
Efficacy	121 LPW
W/Ft	6.6
CRI	90

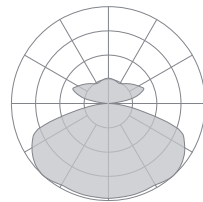

LPD: 0.37

Distribution	20/80
Output	800 Lm/Ft
Efficacy	114 LPW
W/Ft	7
CRI	80

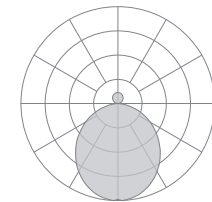

LPD: 0.42

Calculation	FC Avg.	Max	Min	Avg. Min	Max/Min
Workplane	36	52	18	2.1	2.9
Vertical	24	28	16	1.6	1.8

Calculation	FC Avg.	Max	Min	Avg. Min	Max/Min
Workplane	39	66	17	2.3	3.9
Vertical	9	15	13	1.4	1.5

A stylized map of Massachusetts is shown in a light blue color against a dark blue background. The word "MASSACHUSETTS" is printed in white, uppercase letters across the center of the map. On the eastern coast, a white star is placed, with a thin white line extending from it to the word "PLYMOUTH" which is also in white, uppercase letters.

MASSACHUSETTS

PLYMOUTH

Massachusetts Made

Litecontrol has been a Massachusetts-based manufacturer for more than 80 years. Proud of our legacy of service and innovation, we continue to focus on architectural spaces and those who light them.

QS10

Aira, and nearly all Litecontrol products, ship within 10 days after order receipt.

Controls and Lighting Technology



NX Lighting Controls provides options for standalone and networked integrated sensor with wired or wireless connectivity for NX system deployments.



SpectraSync™ is an easy and intuitive white tuning solution which accommodates a variety of applications.

Tunable White offers users the ability to tailor CCT to their personal preference, enhancing task visibility, material and colors, or the aesthetics of the space. (Available with 2700K–6500K).



TriGain® technology, with its patented narrow-band red emission, provides high color quality and efficiency. With rising industry trends in color quality toward preferred performance ranges, TriGain® Technology delivers 90 CRI color quality at 80 CRI efficacy.

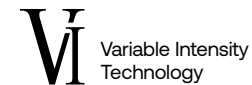

Variable Intensity Technology is a simple method for specification of luminaire lumens and wattage to meet the exacting demands of each project.

Vi Technology provides verifiable wattage for compliance with programs, agencies and state and local codes.

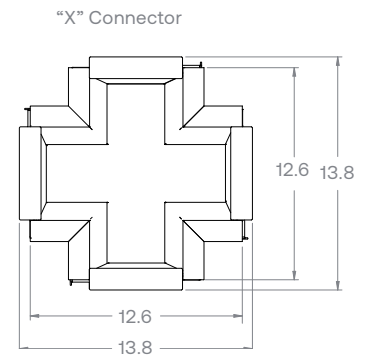
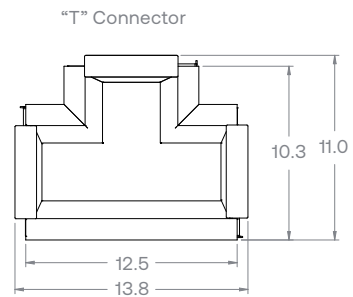
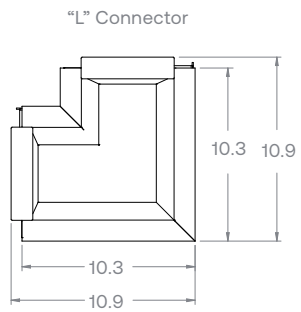
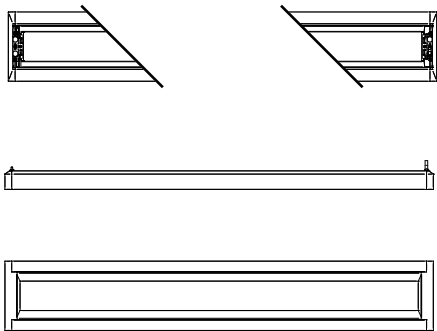
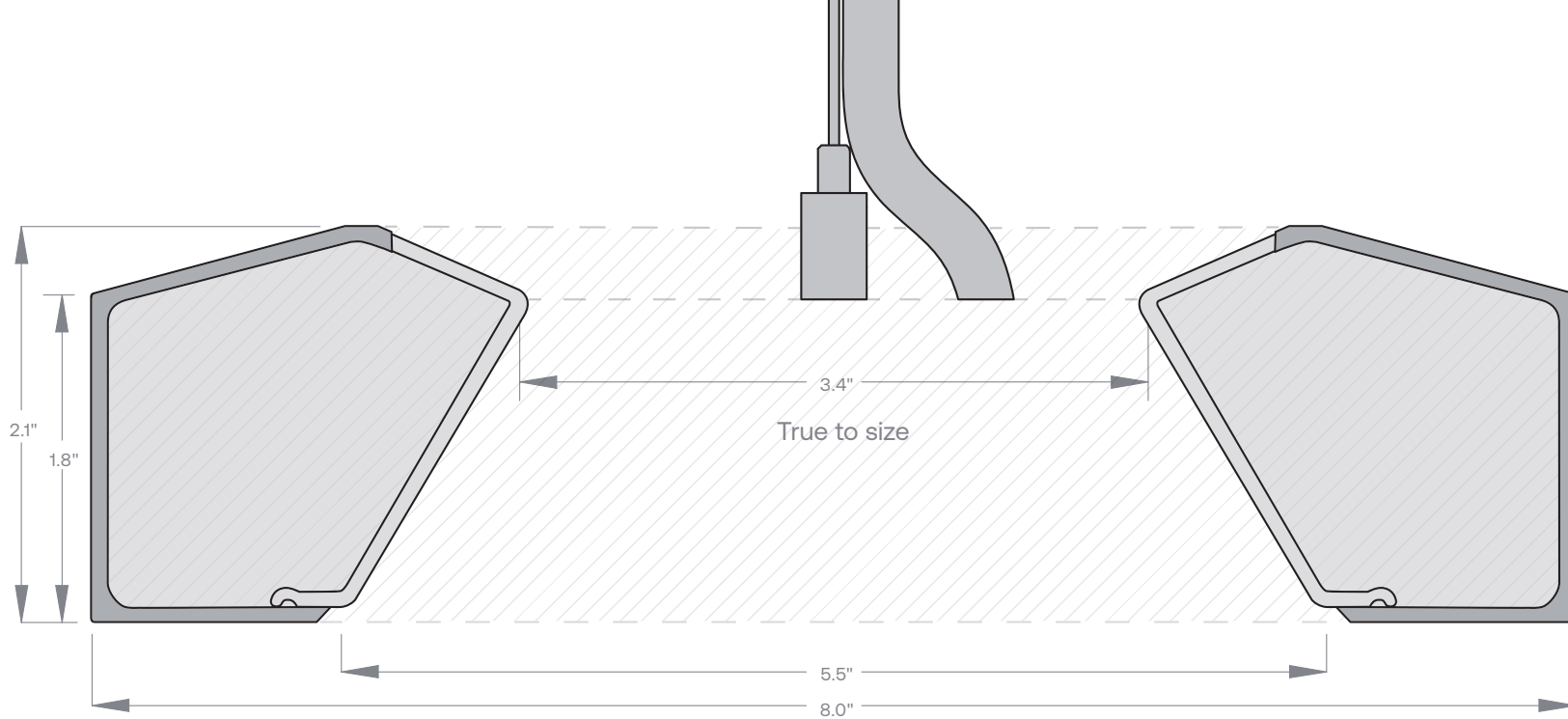

Catalog information

Series	Mounting	Fixture Distribution	Indirect Optics	Row Length	Max length in Row	Diffuser	Finish
AIRA Open center linear pendant	P Pendant	SD Semi-Direct	LPA Low Peak Angle	' Enter in foot increments	2 2'	SOF Soft Diffuse Lens	WHS White, Smooth (C1)
	W Wall (ADA compliant)				3 3'		
					4 4'		
					5 5'		
					6 6'		
					8 8'		GYS Gray, Smooth (C4)
							BLS Black, Smooth (C5)
							CC Custom Color

Crossbar Insert Finish	CCT/CRI	Lumen Output	Dimming	Circuiting	Voltage	Suspension Kit
RWHS White, Smooth (C1)	27K9 2700K, 90CRI	SD015 150 (min) to	D01 0-10V; 1% Dimming	1C Single Circuit	UNV Universal (120V-277V)	FA1 Suspension Kit, 51"
RGYS Gray, Smooth (C4)	30K9 3000K, 90CRI		D05 0-10V; 5% Dimming			347 347V
RBLS Black, Smooth (C5)	35K9 3500K, 90CRI	SD150 1500 (max)	NDM Non-Dimming			FA3 Suspension Kit, 219"
RWH White, Textured	40K9 4000K, 90CRI		LEC Lutron Hi-Lume 1% EcoSystem			FA4 Suspension Kit, 363"
RGY Gray, Textured	50K9 5000K, 90CRI		DALIP DALIP			P Swivel Stem Kit, 36"
RBL Black, Textured	2765T 2700-6500K Tunable White, 90CRI		SEN For use with Sensors			
RGT Graphite						
RPP Pink Panache						
RGH Grasshopper						
RCOS Copper						
RX Custom Color						

CONTROL OPTIONS

NX Networked – Wireless

NXWSM	NX Networked Wireless Enabled Integral NXSMP2-SMI PIR Occupancy Sensor with Automatic Dimming Photocell and Bluetooth Programming
NXCS	NX Connect NXC-WIZ20 Wireless Indoor Occupancy and Photocell Sensor

OPTIONAL

Nightlight	Emergency	Patterns
NL Nightlight Circuit Required. Enter quantity. 2NL = 2 nightlight circuits / row	EF 10W Emergency Battery Pack (CEC Title 20 Compliant) Enter quantity. 2EF = 2 emergency batteries / row	C90L Illuminated "L" C90T Illuminated "T" C90X Illuminated "X"

NOTE: For overview purposes only. Not all options are available in combination. For complete ordering information and Quick Ship availability, see specification sheets.

Always On.

At Current, inspiration flows both ways. In providing the lighting and controls solutions that help create beautiful, functional and safe environments, we're inspired by the people who live, work and play in those spaces.

Only Current can provide reliable performance, responsive service, and the uncompromising quality you expect from an industry leader every time, always.

Our Vertical Markets



Commercial

Stores, Offices, Hotels, Supermarkets, Restaurants, Education



Industrial

Manufacturing Centers, Warehouses, Food Processing Plants



Municipal

Roadways, Residential Streets, Shared Spaces



Specialty

Signage, Transportation, Healthcare

Our Solutions



LED Lighting

Optimize utilities to end excess energy spending, promote safety and improve aesthetics



Controls, Sensors & IOT Solutions

Improve space utilization and increase productivity, and find actionable insights with IOT



Energy Management Systems

Establish more sustainable energy practices across an enterprise

Current



Industry-leading portfolio of innovative product and tech brands

With the convergence of two iconic leaders who each bring rich histories and deep talent, Current is uniquely positioned to help our customers solve complex challenges with the industry's widest selection of advanced lighting and intelligent controls.

HLI Brands

Current's HLI Brands portfolio of products offers well-known and respected brands, offering a comprehensive range of indoor luminaires, outdoor luminaires, and connected lighting solutions for architectural, commercial, industrial and institutional applications.





ARCHITECTURAL AREA LIGHTING

BEACON

COLUMBIA LIGHTING

COMPASS

DUAL-LITE

EXO

FORUM

KIM LIGHTING

KURT VERSEN

LIFESHIELD

LITECONTROL

NX LIGHTING CONTROLS

PRESCOLITE

Current - HLI Brands

701 Millennium Blvd.
Greenville, SC 29607

currentlighting.com/litecontrol

© 2024 Litecontrol Corporation. All rights reserved. Information and specifications subject to change without notice. All values are design or typical values when measured under laboratory conditions.

(Rev 02/02/23/2024)

LC_Aira_Brochure_R01
