



PGN Application Guide

SAVE INSTALLATION TIME AND MONEY

The PGN functions in both “normally on” and emergency modes, eliminating the need for multiple fixtures.

The PGN LED Sconce offers exceptional lighting performance with minimal maintenance. It will operate from any 120/277VAC power source and any 6-12V DC power source in the event of a power failure. This dual purpose input design simplifies exit/entrance location installation for the electrical contractor or plant maintenance electrician.

For example, each building entrance/exit location could require up to **four pieces** of equipment to meet Code:

Building Interior

- Exit sign

- Emergency lighting unit

Building Exterior

- Wall pack

- Emergency lighting unit

For a simpler, more cost effective installation, pair an HCXURWRC12 "combo" emergency lighting unit/LED exit sign with remote capacity "back to back" with a PGN. Only **two pieces** of equipment are needed to do the job, saving installation time and equipment cost! The following illustrations will show just how simple this is.

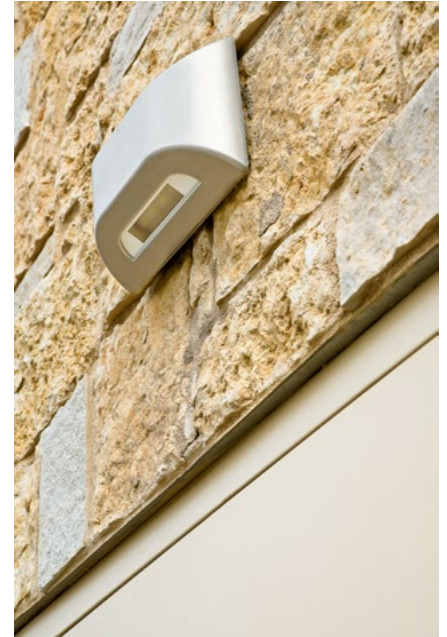

EMERGENCY LIGHTING FOR ENTRANCE/EXIT LOCATIONS

PGN

Outdoor mounted. Normal power supplied from utility 120/277VAC source. Emergency power is provided when HCX unit transfers and supplies 6V DC power to PGN.

HCXURWRC12

Indoor mounted. Normal power supplied from utility 120/277VAC source. Contains 6V DC battery with remote capacity and transfer protocol. Upon loss of power, HCX unit transfers and supplies 6V DC power to exit, two heads on HCX and PGN for emergency lighting function.

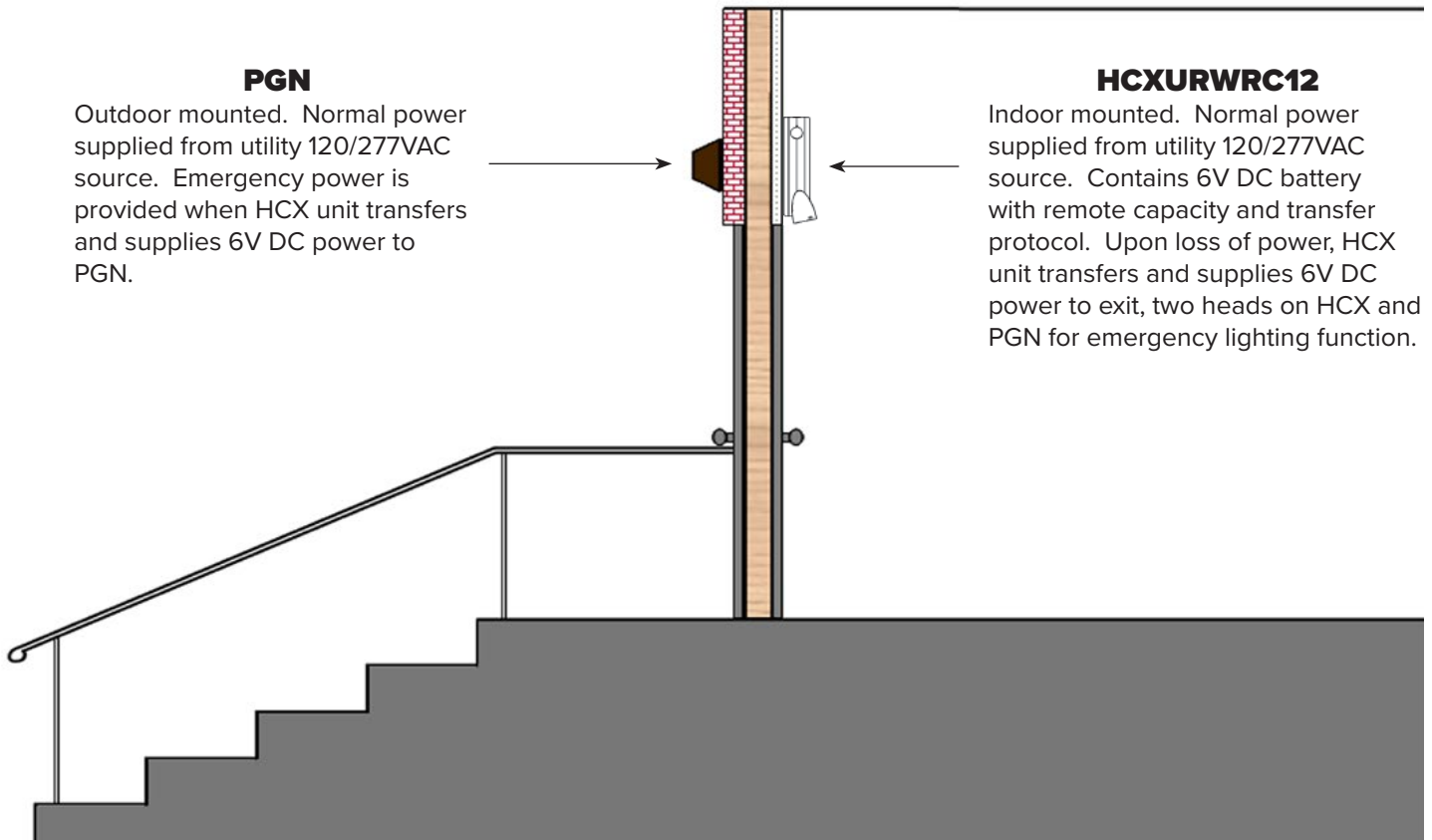

WIRING DIAGRAM

In this example a PGN is supplied with utility AC power for normally on use, with a photo control or manual wall switch in-line if desired, and is supplied with 6V DC power for emergency operation from an HCX emergency lighting unit with remote capacity.

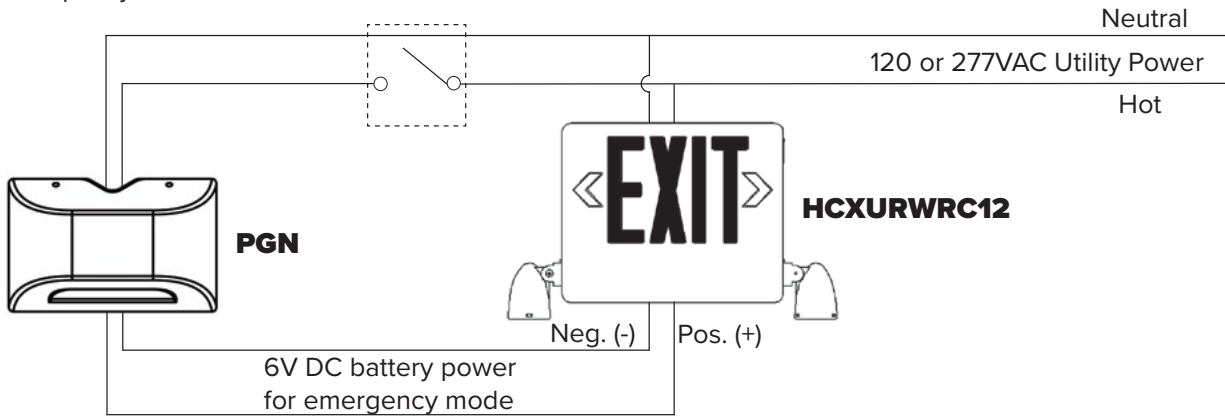

COMPATIBLE EMERGENCY LIGHTING UNITS

The chart below lists several Dual-Lite solutions for powering the PGN during a power failure.

Type	Model	6 V DC	12V DC	120/277 VAC	Remote Capacity	# of PGN
Combo ⁽¹⁾	HCXURWRC12	✓			12 W	1
	HCXURW-0-RC12	✓			23 W	1
Unit ⁽¹⁾	LZ30	✓			20 W	1
	LZ35-12V		✓		25 W	1
	LZ65	✓			55 W	4
	LZ65-12V		✓		55 W	4
	LM33	✓			18 W	1
	LM40	✓			25 W	2
	LM40-12V		✓		25 W	2
	AS80	✓			65 W	5
Inverter	LiteGear® LG1			✓	100 W	5
	Synchron, LSN			✓	KWA Rating	Many



⁽¹⁾ Each instance assumes standard lamp-heads are used on the unit, except the HCXURW-0-RC12, which is supplied without lamp heads.

WHAT IS REMOTE CAPACITY?

Remote capacity models provide means for delivering DC power to additional exit signage and emergency lighting equipment during power outages.

Other Dual-Lite unit equipment with remote capability:
LZ, LM, TG, ERS, N4X, C1D2, and XPB
See PSG for specific ordering information

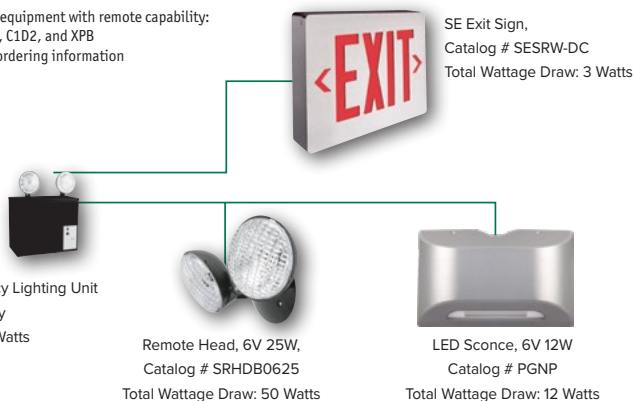

	Wattage Capacity (90 Minute Operation)
AS80 Emergency Lighting Unit	80.00
Less two each 7.2 Watts lamp integral to AS80 unit	(14.40)
Less SRHDB0625 Twin Remote Head	(50.00)
Less PGNP	(12.00)
Less Exit Sign SESRW-DC	(3.00)
TOTAL WATTAGE CAPACITY REMAINING*	0.60

* The National Electric Code limits voltage drop to 5% of nominal. Actual results may vary. Circuit runs must be of sufficient capacity to maintain operating voltage when remote fixtures and/or exit signs are connected to the emergency lighting unit. Refer to the voltage drop tables for sizing and distance of wire run.