

For Vacancy Mode a momentary switch is required.

SPECIFICATIONS

- Input Voltage: 100-277V~ 50/60 Hz, 20A.
- Output Voltage: 24VDC, 250mA (Class 2), short circuit protected.
- Relay Contact Rating: 20A, 100V to 277VAC, 50/60 Hz. 1HP at 120VAC or 2HP at 240/277VAC.
- Mounts inside or outside junction box.
- Use 1/2" conduit locknut to secure unit to junction box or to lighting fixture.
- Powers up to 6 sensors.
- UL2043 Plenum rated. Acceptable for use in environmental air handling spaces (plenums) other than ducts per NEC® article 300.22 (C).

IMPORTANT NOTE: PLEASE READ BEFORE INSTALLING.

CAUTION: RISK OF ELECTRICAL SHOCK.

- Disconnect power before installing. Never wire energized electrical components.
- For installation by a qualified electrical in accordance with all local and national electrical codes.
- Use Copper Conductors Only.
- Check to see that the device type and ratings is suitable for the application.
- Do not install if product has any visible damage.
- If moisture or condensation is evident, allow the product to dry completely before installation.
- Operate between -13°F (-25°C) and 104°F (40°C). 0% to 90% humidity, non-condensing.

INSTALLATION

1. Turn power OFF at the service panel.
2. Use #6-32 pan head screws or 1/2" conduit locknut to secure unit if mounting inside junction box.
3. Connect the unit to the circuit as shown in the wiring diagram Fig. 1.

Note: The maximum length of #18-22 AWG wire between the control unit and associated sensors should not exceed 200ft.

UVPPHD Manual ON/OFF Operation

4a. Automatic ON (occupancy) configuration and operation:

The device is factory configured to operate in automatic ON mode. Connect red, black, and blue low voltage wires to corresponding wires to sensors and cap the orange wire.

The load will turn ON automatically when motion is detected and will turn OFF when sensors time out.

4b. Manual ON (vacancy) configuration and operation:

Configure the device for manual ON operation by cutting the yellow wire loop and cap the ends separately. Connect red, black, and blue low voltage wires to corresponding wires to sensors. Connect the orange wire to a momentary pushbutton switch. The momentary pushbutton switch (user supplied) needs to be connected between the orange manual ON wire and red +24VDC wire. Turn the loads ON manually by pressing the momentary switch.

Motion must be detected within 30 seconds of pressing the momentary switch to keep the load ON.

If the load turns OFF automatically, it can be turned back on without pressing the momentary switch if motion is detected within 30 seconds.

Pressing the manual switch while the load is ON turns the load OFF regardless of sensor status.

5. Turn power ON at service panel.

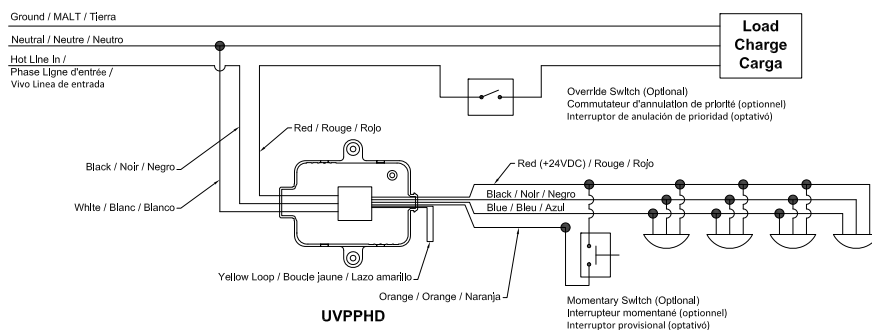
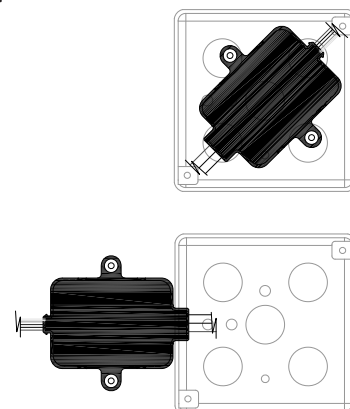

Fig. 1



72-00598A