

For Vacancy Mode a momentary switch is required.

SPECIFICATIONS

- Input voltage: 100-277V @ 50/60Hz.
- Max load rating: 20A, 100-277V; 1HP @ 120V; 2HP @ 240/277v.
- Mounts inside or outside junction box.
- Use ½" conduit locknut to secure unit to junction box or lighting fixture.
- UL2043 Plenum rated. Acceptable for use in environmental air handling spaces (plenums) other than ducts per NEC® article 300.22 (C).

DESCRIPTION

The MPSHD is designed for use with a UVPPHD control unit and the following Current sensors:

- OMNIDT Series: Adaptive Dual Technology (Passive Infrared & Ultrasonic) Sensors.
- OMNIUS Series: Adaptive Ultrasonic Sensors.
- OMNIIR Series: Adaptive Passive Infrared Sensors.
- WSP Series: Passive Infrared Sensors

The MPSHD contains an internal relay for the control of an external load. The MPSHD is designed for +24VDC operation and derives this power from a UVPPHD control unit. The MPSHD is typically used when: 1) it is desired to switch more than one electrical circuit when motion is sensed or; 2) the load exceeds the maximum allowable ratings of the control unit making it necessary to split the circuit.

PRE-INSTALLATION

1. **NOTICE:** For installation by a qualified electrician in accordance with national and local codes and the following instructions.
2. **NOTICE:** For indoor use only. Operate between -40°F (-40°C) and 149°F (65°C). Below 32°F (0°C) must use suitably rated non-metallic enclosure. 0% to 90% humidity, non-condensing.
3. **CAUTION: RISK OF ELECTRIC SHOCK. Disconnect power before installing. Never wire energized electrical components.**
4. **CAUTION: USE COPPER CONDUCTORS ONLY.**
5. **NOTICE:** Do not install if any damage to product is noted.

INSTALLATION OF MPSHD

1. **Disconnect Power.**
2. Remove cover plate from appropriate wiring junction box.
3. Mount MPSHD using supplied locknut. (See mounting options on page 2)
4. Use Listed / Certified twist-on connectors (wire nuts) to connect the line voltage wires in the wiring junction box as shown in the wiring diagram.
5. Install appropriate control unit, sensors and low voltage cable per installation instructions. Refer to the load chart on page 2 for the maximum number of sensors and/or secondary MPSHD relays.
6. Connect the low voltage wires for the control unit as shown in the wiring diagram.
7. Insulate all exposed leads with Listed/Certified electrical tape or twist-on connectors (wire nuts).
8. Replace cover plate from wiring junction box and reconnect power.

MPSHD Manual ON/OFF Operation

9. Automatic ON (occupancy) configuration and operation:

- a. The device is factory configured to operate in automatic ON mode. Connect red, black, and blue low voltage wires to corresponding wires to sensors and cap the orange wire. The load will turn ON automatically when motion is detected and will turn OFF when sensors time out.

72-00600A

10. Manual ON (vacancy) configuration and operation:

a. Configure the device for manual ON operation by cutting the yellow wire loop and cap the ends separately. Connect red, black, and blue low voltage wires to corresponding wires to sensors. Connect the orange wire to a momentary pushbutton switch. The momentary pushbutton switch (user supplied) needs to be connected between the orange manual ON wire and red +24VDC wire. Turn the loads ON manually by pressing the momentary switch. Motion must be detected within 30 seconds of pressing the momentary switch to keep the load ON. If the load turns OFF automatically, it can be turned back on without pressing the momentary switch if motion is detected within 30 seconds. Pressing the manual switch while the load is ON turns the load OFF regardless of sensor status.

11. Turn power ON at service panel.

Sensors	MPSHD*
1	4
2	3
3	2
4	2
5	1
6	0

Load Chart

When installed with a UVPPHD control unit.

Low voltage devices (sensors, photocells, low voltage switches) powered by the UVPPHD control unit.

***Note:** The Maximum number of recommended MPSHD units on the Load Chart is based on sensors with power ratings of 33mA. Additional units may be connected if a lower rated sensor is used. Please consult our Technical Service Department for additional details.

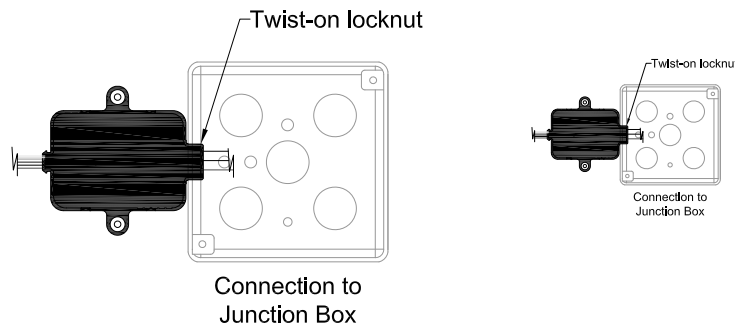
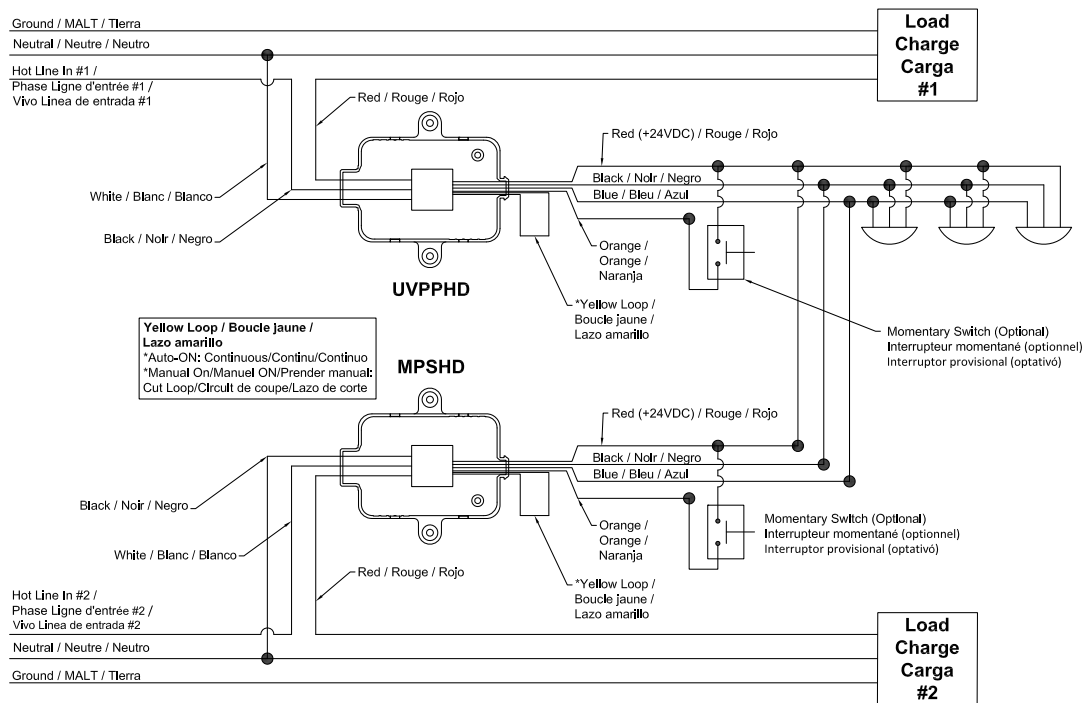

72-00600A