

PRECAUTIONS

Read and understand all instructions before beginning installation.

- CAUTION: FOR USE WITH CLASS 2, LOW VOLTAGE SYSTEMS ONLY. DO NOT USE IN HIGH VOLTAGE APPLICATIONS.
- NOTICE: Class 2 Device, 12-24V, 10mA
- NOTICE: Raintight Device
- NOTICE: Suitable for Use in Other Environmental Air Space (Plenums) in Accordance with Section 300.22, (C) of the National Electrical Code.
- NOTICE: For installation by a licensed electrician in accordance with National and/or local Electrical Codes and the following instructions.
- Confirm device ratings are suitable for application prior to installation. Use of device in applications beyond its specified ratings or in applications other than its intended use may cause an unsafe condition and will void manufacturer's warranty.
- Use only approved materials and components (i.e. wire nuts, electrical box, etc.) as appropriate for installation.
- NOTICE: Do not install if product appears to be damaged.
- Contains Transmitter Module FCC ID: QOQ13
- This device complies with FCC part 15 Rules. Operation is subject to the following two conditions:
 1. This device may not cause harmful interference,
 2. This device must accept any interference received, including interference that may cause undesired operation.
- FCC Interference Statement (Part 15.105 (b))
- This equipment has been tested and found to comply with the limits for a Class B digital device, pursuant to Part 15 of the FCC Rules. These limits are designed to provide reasonable protection against harmful interference in a residential installation. This equipment generates uses and can radiate radio frequency energy and, if not installed and used in accordance with the instructions, may cause harmful interference to radio communications. However, there is no guarantee that interference will not occur in a particular installation. If this equipment does cause harmful interference to radio or television reception, which can be determined by turning the equipment off and on, the user is encouraged to try to correct the interference by one of the following measures:
 - Reorient or relocate the receiving antenna.
 - Increase the separation between the equipment and receiver.
 - Connect the equipment into an outlet on a circuit different from that to which the receiver is connected.
 - Consult the dealer or an experienced radio/TV technician for help.
- FCC Part 15 Clause 15.21: Changes or modifications not expressly approved by the party responsible for compliance could void the user's authority to operate the equipment.
- ISED RSS-Gen Notice:

This device complies with Industry Canada's license-exempt RSSs. Operation is subject to the following two conditions:

1. This device may not cause interference; and
2. This device must accept any interference, including interference that may cause undesired operation of the device.

Le présent appareil est conforme aux CNR d'Industrie Canada applicables aux appareils radio exempts de licence. L'exploitation est autorisée aux deux conditions suivantes:

1. l'appareil ne doit pas produire de brouillage;
2. l'appareil doit accepter tout brouillage radioélectrique subi, même si le brouillage est susceptible d'en compromettre le fonctionnement.

SAVE THESE INSTRUCTIONS!

DESCRIPTION

The BTSMP sensor modules feature a Passive Infrared (PIR) occupancy sensor and daylight sensor specifically designed for installation within a lighting fixture. When used with the appropriate lighting fixture and dimming driver with auxiliary power, the sensors can be programmed to provide automatic light level control based on occupancy and/or the amount of ambient daylight. An integral Bluetooth® radio enables the sensor to be programmed locally using the NX Lighting Controls mobile app on an Android™ or iOS® smart device.

INSTALLATION

Note: The BTSMP sensors are designed to mount on a flat surface in a round opening measuring between 1 3/16" and 1 1/4" in diameter.

1. Turn power off at the service panel before installing sensor.
2. Choose a mounting location on the fixture where the sensor lens will be oriented downward as close to level as possible. Use the supplied locking ring and gasket to secure the sensor in place. Do not over tighten the locking ring.
3. Electrically connect the sensor to the luminaire's dimming driver per the wiring diagram shown below.
4. Assemble or reassemble the fixture as required.
5. Turn power on and allow sensor (2) minutes to stabilize.
6. Verify sensor is functioning by waving hand under lens and observing that the sensor's red light (located under the lens) flashes.
7. Adjust sensor operation using the NX Lighting Controls mobile app.

MOUNTING DETAIL

- BTSMP-HMO: Maximum height - Indoors: 45 ft / Outdoors: 30 ft, minimum 16 ft
- BTSMP-LMO: Maximum mounting height is 16 ft, minimum 8 ft
- BTSMP-LMI: Maximum height is 14 ft, minimum 8 ft (Recommended: 8 ft to 12 ft AFF (Above Finished Floor))
- BTSMP-OMNI: Maximum height is 12 ft, minimum 8 ft

BTSMP-HMO / BTSMP-LMO Fixture Mount

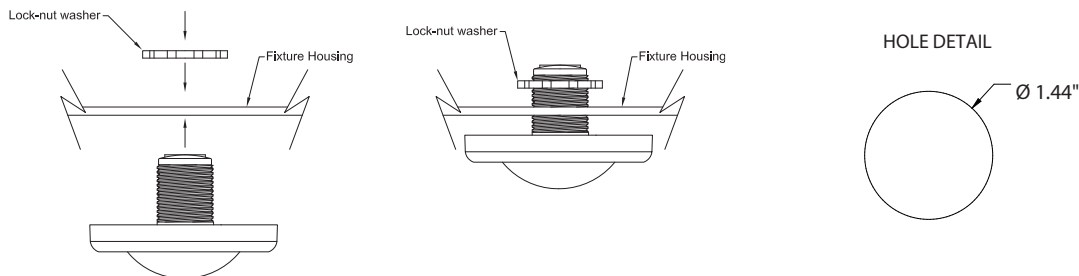

BTSMP-LMI Fixture Mount

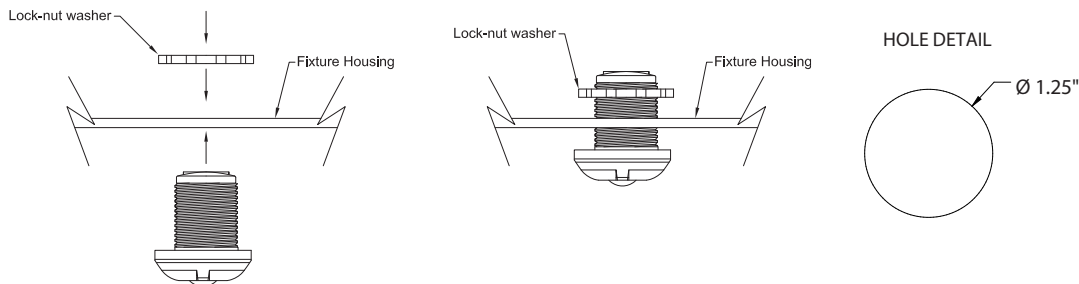

BTSMP-OMNI Fixture Mount

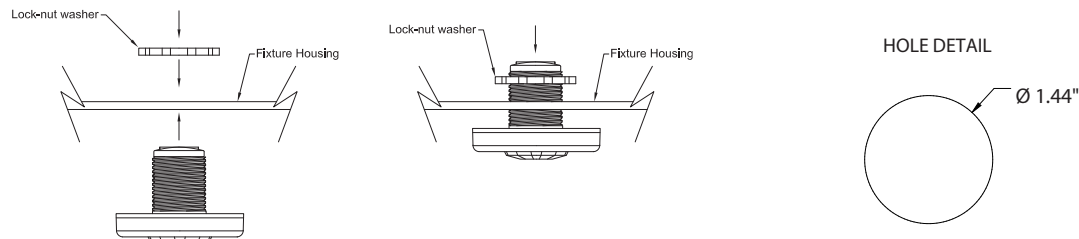

WIRING DIAGRAMS

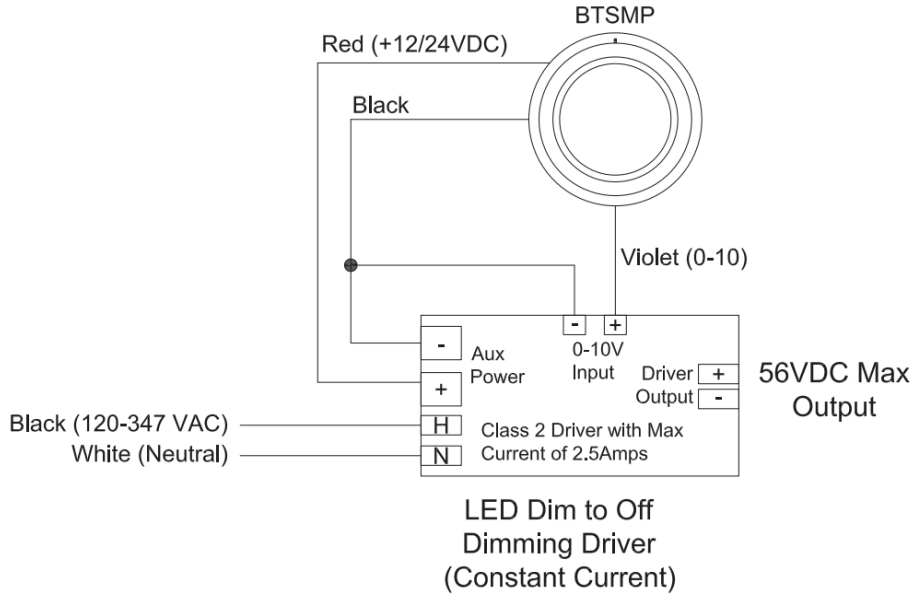

BTSMP Sensor Connected to Dim to OFF Driver with Aux Supply (+12/24VDC)

COVERAGE PATTERNS

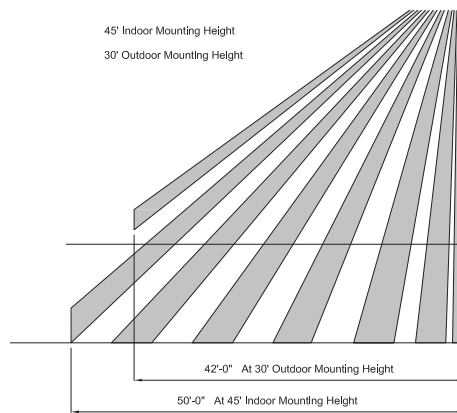

BTSMP-HMO
Sensor Lens Coverage and Detection Patterns
When Mounted at 30ft and 45ft with Standard Lens

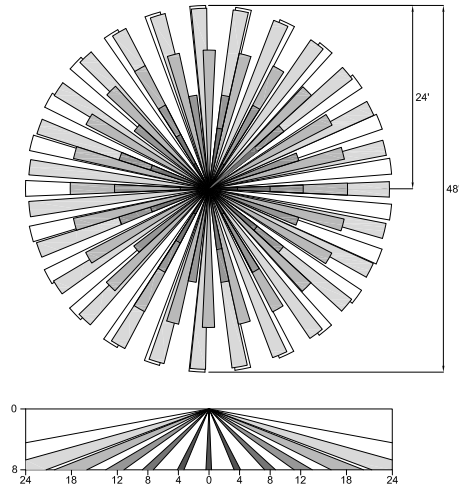

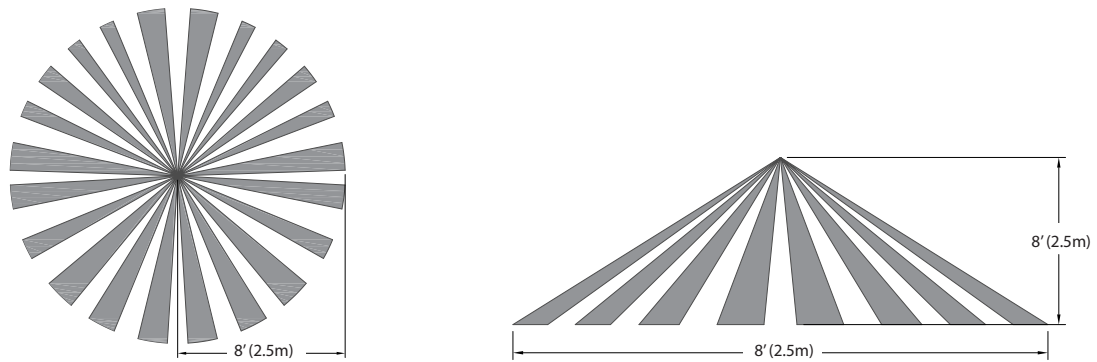

BTSMP-LMO

Sensor Lens Coverage and Detection Patterns
When Mounted at 8ft with Low Mount Lens

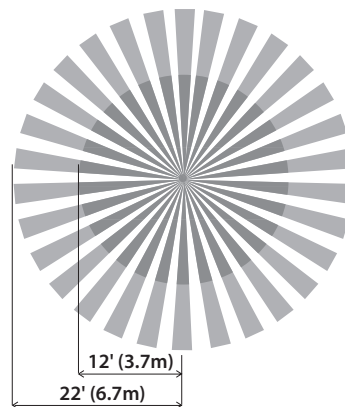

BTSMP-LMI



-  **Minor Motion**
-  **Major Motion**

BTSMP-OMNI