

**PRECAUTIONS**

Read and understand all instructions before beginning installation.

**NOTICE:** For installation by a licensed electrician in accordance with National and/or local Electrical Codes and the following instructions.

Disconnect switch or a circuit breaker must be provided and marked as the disconnecting device.

Disconnect switch / circuit breaker must be within reach of operator.

**CAUTION:** RISK OF ELECTRICAL SHOCK. Turn power off at service panel before beginning installation. Never wire energized electrical components.

**CAUTION:** USE COPPER CONDUCTOR ONLY

Confirm device ratings are suitable for application prior to installation. Use of device in applications beyond its specified ratings or in applications other than its intended use may cause an unsafe condition and will void manufacturer’s warranty.

**NOTICE:** Do not install if product appears to be damaged.

**SAVE THESE INSTRUCTIONS!**

**DESCRIPTION**

The NX Room Controller is a self-contained intelligent power pack. It contains either one or two independently controlled outputs. Optional 0-10VDC outputs are available for controlling dimmable ballasts and LED drivers. The NX Room Controller also features four Smart Ports that provide plug and play support for NX occupancy sensors, daylight sensors and manual control switches. The NX Room Controller can operate stand alone or networked with other NX controls.

**SPECIFICATIONS**

Max Load Rating	120/277/347VAC (SPST) 20A Incandescent 20A Magnetic Ballast 16A Electronic Ballast/Driver 1HP motor load
Dimming	0-10VDC, Class 2, Current sink, 60mA per channel
Operating Temp	0°C to +40°C
Certifications	Conforms with UL916 and Certified to CAN/CSA C22.2 #205-12 Plenum rated
Warranty	Five-year limited warranty

**INSTALLATION**

1. DO NOT DISCARD THE INCLUDED MAC ADDRESS LABELS. SEE STEP (5) BELOW.
2. Turn power off at the service panel.
3. Mount the Room Controller (RC) to the outside of a junction box using the Room Controller’s extended ½” chase nipple. Secure to box with enclosed EMT nut. (See Figure 1)
4. The Room Controller has a MAC address label affixed to the outside of the unit. Place the enclosed MAC address label(s) in a log book and record the location of the Room Controller and the circuit(s) it controls. The MAC address will be needed later during the system setup process.
5. If control devices (e.g. occupancy sensors, daylight sensor and switches) are going to be used, attach them to any available Smart Port with the appropriate CAT5 device cable. Similar devices (e.g. switches) may be daisy chained together from the same Smart Port. ( See Figure 2)
6. Electrically connect the Room Controller to the circuit(s) as shown in Figure 3. Reapply power at service panel.
7. Test installation as follows:
  - a. Momentarily press Button A to toggle Load A (red wire) ON and OFF
  - b. Momentarily press Button B to toggle Load B (blue wire) ON and OFF (2 Relay Models Only)
  - c. With Load A ON, press and hold Button A down to dim Load A down.  
Release Button A and press again to dim Load A up.
  - d. With Load B ON, press and hold Button B down to dim Load B down.  
Release Button B and press again to dim Load B up.

## OPERATION GUIDE

The NX Room Controller is designed to control and manage lighting within a single room or zone in a building. Working in conjunction with an occupancy sensor(s), daylight sensor, and wall switch station(s), the room controller intelligently responds to inputs to perform the required lighting control sequence of operation. The room controller operates with the connected control devices as a stand-alone local control system but can be extended to participate in a building-wide networked lighting control system with the addition of the NXHNB Network Bridge Module.

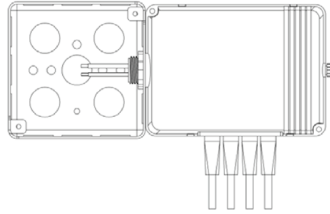

Figure 1: Room Controller mounted to 4x4 junction box

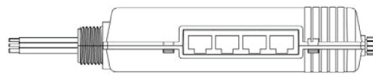

Figure 2: Room Controller SmartPORTs – Connect control devices  
(e.g. occupancy sensors, daylight sensor and switches) to any available Smart Port

## CONNECTING MULTIPLE ROOM CONTROLLERS

Room controllers can be inter-connected to expand the number of relays and dimmers in the room or to allow the use of more than one voltage. Use CAT5 cable(s) to connect the room controllers in a daisy chain configuration. That is, no more than one RJ45 port in each room controller should be used for this connection. A maximum of 8 room controllers may be connected for a maximum of 16 relays and 16 dimmers. Self configuration will function normally up to a maximum of 6 loads. Manual configuration will be required beyond 6 loads.

## CONNECTING LOW VOLTAGE CONTROL DEVICES

The Room Controller provides a source of 24 VDC current to power the connected control devices such as switch stations and sensors. A maximum of 250 mA of 24 VDC current is available. Since the control components draw differing amounts of current, the following table should be used to determine how many control devices can be connected to a single room controller. In cases where two or more room controllers are connected together, the power budget is determined for each room controller based on the control devices that are plugged into that room controller. See Figure 3.

### MAXIMUM POWER BUDGET PER ROOM CONTROLLER = 30 LOADS

- Switch station = 1 Load
  - PIR only Occupancy sensor = 1 Load
  - PIR only Occupancy sensor with RP option = 2 Loads
  - Dual Technology and Ultrasonic Occupancy sensor = 3 Loads
  - Dual Technology and Ultrasonic Occupancy sensor with RP option = 4 Loads
  - Daylight Sensor (photocell) = 1 Load
- NOTE: Only one daylight sensor can be connected in each room/zone

## SELF CONFIGURATION

The sequence of operation in the room will automatically reconfigure as devices are plugged into the room controller as described in the following sections. Note that self configuration will automatically be disabled once the room has been manually configured. See Manual Configuration section.

## OCCUPANCY SENSORS

The NX room controller is compatible with any low voltage Current vacancy/occupancy sensor that uses the red/black/blue control wires. A wiring adapter (RJ45ADAPTOR) is required to make the wiring transition from the flying leads on the sensor to the RJ-45 Smart Port on the room controller. Current sensors ordered under model NXOS series model numbers are automatically supplied with the adapter and a short CAT5 jumper cable.

The sensor can be connected to the Room Controller Smart Port using a pre-terminated CAT5 cable (see Figure 3). Alternately, the adapter can be connected to the Room Controller Smart Port and one or more sensors connected using traditional low voltage wiring. The adapter is color coded to match the flying leads on the sensors.

NOTE: Once any NX digital switch station is connected to the Room Controller, the mode of operation will automatically switch to vacancy mode (manual on) for all loads. To change one or more load(s) to automatic on operation see Manual Configuration section.

### DIGITAL SWITCH STATIONS

The NX Digital Switch Stations will automatically configure themselves to control the available loads within 5 seconds after being connected to the Room Controller. For best results, do not press any buttons for 5 seconds after plugging in a switch station. This allows time for the system to self configure and stabilize.

Model number switch stations NXSW-1, NXSW-2, NXSW-3, NXSW-4, NXSW-6 will have all buttons configured for ON/OFF toggle operation by default. These stations will self configure to sequentially control the loads. For example, a NXSW-1 will control load 1, a NXSW-2 will control loads 1 and 2, etc. The relationship between the buttons and the loads can be changed. See Manual Configuration section. NOTE: If the zone has more loads than buttons, the last button in the sequence will automatically control the remaining loads. This insures that no load is left uncontrolled during the self configuration process.

The NX Specialty Switch Stations model NXSW-OO and NXSW-TO will self configure the same as the NXSW-1 as described above.

The NX Specialty Switch Stations model number NXSW-RL, NXSW-SS and NXSW-ORLO have dimming functionality and will self configure to control all loads. The relationship of the stations to the dimmed loads can be changed. See Manual Configuration section. The NX Specialty Switch Station model number NXSW-CCT is specifically designed to work with SpectraSync tunable white LED technology. When used with a room controller, the dimming output that is to control color must be set to Color Mode using the NX App or Area Controller GUI.

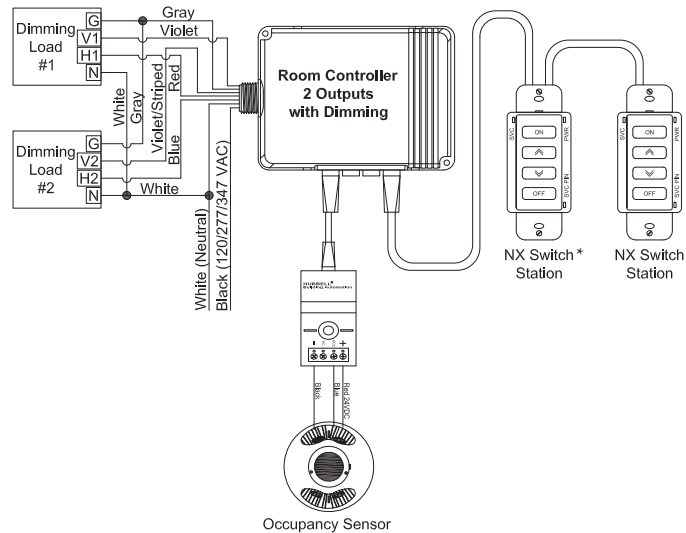

Figure 3

## DAYLIGHT SENSOR

The model NXDS Daylight Sensor will self configure to Load A (red switch wire and violet dimming wire) in Test Mode connected to a room controller. The daylight sensor will become active 30 seconds after the load has been turned on. While the unit is in Test Mode, the photocell operation can be verified by observing Load A lighting while alternately covering the photocell (Load A light will be ON and bright if dimming enabled) or exposing the photocell to bright light (Load A light will be OFF or dimmed if so enabled). The above process will confirm that the Daylight Sensor and Room Controller are functioning. The Daylight Sensor must be calibrated in order to meet project specific requirements. This can often be done using Manual Configuration. To meet requirements for specific foot candle settings, the NX Device Setup App or NXAC-120 Area Controller can be used.

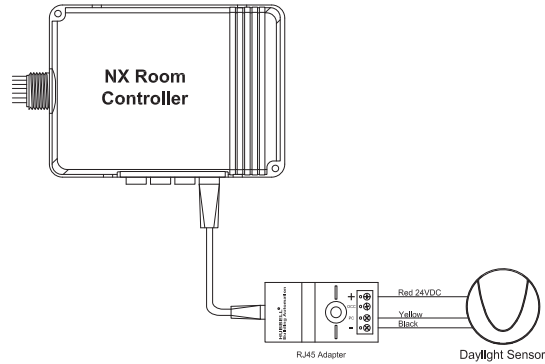

Figure 4

## MANUAL CONFIGURATION

The process of manual configuration allows certain functions to be adjusted using only the A and B pushbuttons and LED indicators on the Room Controller. The functions that can be adjusted are:

1. Assign loads to buttons and stations
2. Configure loads for manual ON (vacancy mode) or automatic ON operation
3. Configure loads to respond to the photocell
4. Calibrate the photocell

## ENTER MANUAL CONFIGURATION MODE

To enter manual configuration mode, simultaneously press and hold buttons A and B on the Room Controller until the A and B LEDs start to alternately blink. Release buttons A and B. The room controller will now be in configuration mode. Load A will be ON and all other loads will be OFF. Note, while in configuration mode no more than one load will ever be on and the A and B buttons on the room controller will not control the loads.

Hint: If more than one load is on or pressing the A or B button switches the associated load, you likely did not press both buttons exactly together when entering configuration mode. Repeat the process to enter manual configuration mode.

## EXIT MANUAL CONFIGURATION MODE

To exit configuration mode, simultaneously press and immediately release buttons A and B. The room controller will resume normal operation.

## ENTER MANUAL CONFIGURATION MODE FROM A SWITCH

Remove the faceplate from any wall switch and locate the rectangular opening in the plastic bezel marked "SVC PIN". Use a thin object such as a straightened paper clip to press the recessed configuration button for 5 seconds. Note that the button is located slightly offset from the opening in the bezel. The LED marked "SVC" will blink while the configuration button is being pressed. Release the configuration button and note that one load turns on and all other loads turn off indicating that the room is in manual configuration mode.

Hint: You may find it more convenient to remove the plastic bezel from the switch during programming. Simply pry off using the notch at the bottom. To reattach, insert the tabs at the top and snap into place at the bottom.

## EXIT MANUAL CONFIGURATION MODE FROM A SWITCH

Press the configuration button for five seconds. Note that the LED marked "SVC" will blink while the configuration button is being pressed. Release the configuration button. The loads in the room will restore to the levels they were prior to entering manual configuration mode.

## ASSIGN LOADS TO BUTTONS

All NXSW switch stations assume default operation of the load(s) when they are plugged into a Smart Port on the Room Controller. The assignment of the loads to the buttons can easily be changed as follows:

Enter configuration mode as described above.

Load A on the first room controller will be ON.

While load A is ON, each button that controls that load will have a lighted LED. To unassign control of the load from the button, press the button to extinguish the LED. To assign the load to another button, press the switch station button to light the LED on the button. Repeat this process for all buttons.

To advance to the next load, press and release button A on the room controller. Load A will turn off and next load will turn ON. Repeat the assignment process above for each load.

For NXSW switch stations that do not have LED indicators, ie. NXSW-OO, NXSW-ORLO, NXSW-RL, etc., press the ON button or the Raise button to assign the load. Press the OFF button or the Lower button to unassign the load.

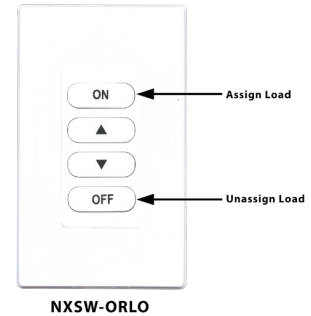

If using the Switch Station method for manual load configuration, tap the recessed configuration button to advance to the next load as necessary.

After all loads are assigned, exit manual configuration mode. Test the button operation and repeat the above if necessary.

## CONFIGURE LOADS FOR AUTO/MANUAL ON OPERATION

Enter manual configuration mode (see above). While load A is ON, the B LED on the room controller will indicate the current operation mode for the load. If LED B is OFF, the load will operate in manual on (vacancy) mode. If LED B is ON, the load will operate in auto ON mode when the motion sensor detects occupancy. Press and release button B on the room controller to change the operation mode for the current load.

To advance to the next load, press and release button A on the room controller. Repeat the above for all loads. When finished, exit manual configuration mode.

Hint: A load set to manual ON (vacancy mode) must be controlled by an NXSW wall switch station otherwise the load will never turn on.

## CONFIGURE LOADS FOR PHOTOCELL OPERATION

Enter manual configuration mode. While in manual configuration mode, simultaneously press and hold buttons A and B for three seconds until the A and B LED begin to alternately blink. This indicates the room controller has transitioned from load configuration mode into photocell configuration mode. While in photocell configuration mode, only one load will be ON. If the selected load has dimming capability, the light will cycle between minimum to maximum to identify itself during the selection process. If the currently selected load is to be controlled by the photocell, momentarily press and release button B on the room controller. LED B will blink in a pattern to indicate the performance level for daylight harvesting.

The blink patterns are as follows:

Double blink/pause indicates normal baseline performance (default setting)

Triple blink/pause indicates more aggressive performance, lights will dim more

Single blink/pause indicates less aggressive performance, lights will dim less

No blinking indicates that the selected load will not participate in daylight harvesting

NOTE: During this process, the load will dim to high, medium or low reflecting the currently selected performance as indicated by the LED blink pattern.

Press and release button B on the room controller to cycle through the performance choices for the selected load. The “more aggressive” selection will cause the light to dim more during daylight harvesting. The “less aggressive” selection will cause the light to dim less.

Hint: If the room controller is equipped with dimming capability (NXRC-1RD or NXRC-2RD), the photocell will assume that its operation will use dimming. If the room controller does not have dimming capability (NXRC-1R or NXRC-2R), the photocell will operate in switching mode based on a default set point of 150 foot candles.

Press and release button A on the room controller save your selection and to advance to the next load. Repeat the above to set the performance for all loads to be controlled by the photocell. Proceed to auto calibration of the photocell.

Hint: the above process can be used to set up multi-zone daylight harvesting in applications where more than one row of lights are to be controlled. Simply select a more aggressive performance for the row closest to the windows and a less aggressive performance for the row away from the windows. Using this process it is possible to set up a room with three zones of daylight harvesting using the triple blink setting for the row by the window, the double blink setting for the row in the center, and the single blink setting for the row away from the window.

## RESET THE ROOM CONTROLLER TO FACTORY DEFAULT SETTINGS

Should you wish to erase all manual configuration and restore the room controller to its factory default settings, perform the following step:

Simultaneously press and hold buttons A and B on the room controller. After a few seconds, LED A and B will begin alternately blink. Continue to hold buttons A and B until the blink pattern changes to a double blink pattern. Release buttons A and B. When the blinking stops, all loads will turn on indicating the room controller has been reset to factory default settings. After a reset, the room will auto configure based on the connected devices.

Hint: If the installation has more than one room controller connected together in the room, the reset process done on any one of the room controllers will reset all of the room controllers.

## RESET FACTORY DEFAULTS USING A SWITCH STATION

Remove the faceplate from any wall switch and locate the rectangular opening in the plastic bezel marked "SVC PIN". Use a thin object such as a straightened paper clip to press the recessed configuration button for at least 10 seconds. Note that the button is located slightly offset from the opening in the bezel. The LED marked "SVC" will blink while the configuration button is being pressed. Release the configuration button and note that all loads in the room turn on indicating that the room has been reset to factory default settings.