



Download the NX Lighting Controls mobile app



INSTALLATION OVERVIEW

The installation instructions contained in this document are provided as a guide for proper and reliable installation. The mounting location should be selected and prepared based on the application. All electrical wiring and mounting hardware (i.e. electrical mounting box, conduit, etc.) should be prepared with consideration of the requirements outlined in the wiring and mounting diagrams included in this document.

These instructions include information as follows:

Precautions

Description

Product Configurations

Enclosure Mounting

Installing Individual Relays

Connecting Panel Power

Connecting Lighting Loads

Using the NX Panel for Control of Emergency Lighting

Connecting NX Devices

Connecting Low Voltage Inputs & Dry Contact Outputs

Connecting to Panel Using NX Lighting Controls mobile app and NX Bluetooth® Radio Bridge with Real Time Clock

Connecting Panel to NX Lighting Controls Network

Troubleshooting

Panel Specifications

Panel Load Schedule Form

Wiring Diagrams

PRECAUTIONS

IMPORTANT SAFEGUARDS

When using electrical equipment, basic safety precautions should always be followed including the following:

READ AND FOLLOW ALL SAFETY INSTRUCTIONS.

- **CAUTION - RISK OF ELECTRICAL SHOCK.** To prevent electrical shock, turn off power at the circuit breaker before installing or servicing unit. Never wire energized electrical components.
- **NOTICE:** For installation by a licensed electrician in accordance with national and/or local Electrical Codes and the following instructions.
- **CAUTION: USE COPPER CONDUCTOR ONLY.**
- **CAUTION: This equipment provides more than one power supply output source. To reduce the risk of electric shock disconnect both normal and emergency sources within this unit before servicing any equipment connected to this unit.**
- Be sure to read and understand all instructions before installing or servicing unit.
- For Indoor use only. Do not use outdoors.
- Do not mount near gas or electric heaters.
- Disconnect switch or a circuit breaker must be provided and marked as the disconnecting device.
- The use of accessory equipment not recommended by the manufacturer may cause an unsafe condition.
- Confirm that device ratings are suitable for application prior to installation.
- No user serviceable parts contained inside unit. Refer all service-related questions to the factory.

72-00668G

- All servicing shall be performed by qualified service personnel.
- Equipment should be mounted in locations and at heights where it will not readily be subjected to tampering by unauthorized personnel.
- Use only approved materials and components (i.e. twist on connectors, electrical box, etc.) as appropriate for installation.
- **NOTICE:** Do not install if product appears to be damaged.
- If the equipment is used in a manner not specified by the manufacturer, the protection provided by the equipment may be impaired.
- Do not use this equipment for other than intended use.

SAVE THESE INSTRUCTIONS!

ENCLOSURE MOUNTING

The NX Panel is typically installed near the circuit breaker panel. Select an appropriate location that meets the environmental conditions listed in the specification section of this document. The panel interior is divided into high voltage and low voltage areas as shown in Figure 1 below. Select an appropriate location for incoming line voltage panel power, branch circuits to be controlled and low voltage input wiring. The housing is supplied with conduit knockouts labeled to indicate line or low voltage wiring use. All terminations within the panel enclosure require installation by a licensed electrician in accordance with national and/or local Electrical Codes.

Locate the enclosure on the mounting surface and use a level to ensure that it is properly oriented and aligned. Secure the enclosure to the mounting surface with hardware as appropriate for the application using the keyed mounting holes as shown below in Figure 2.

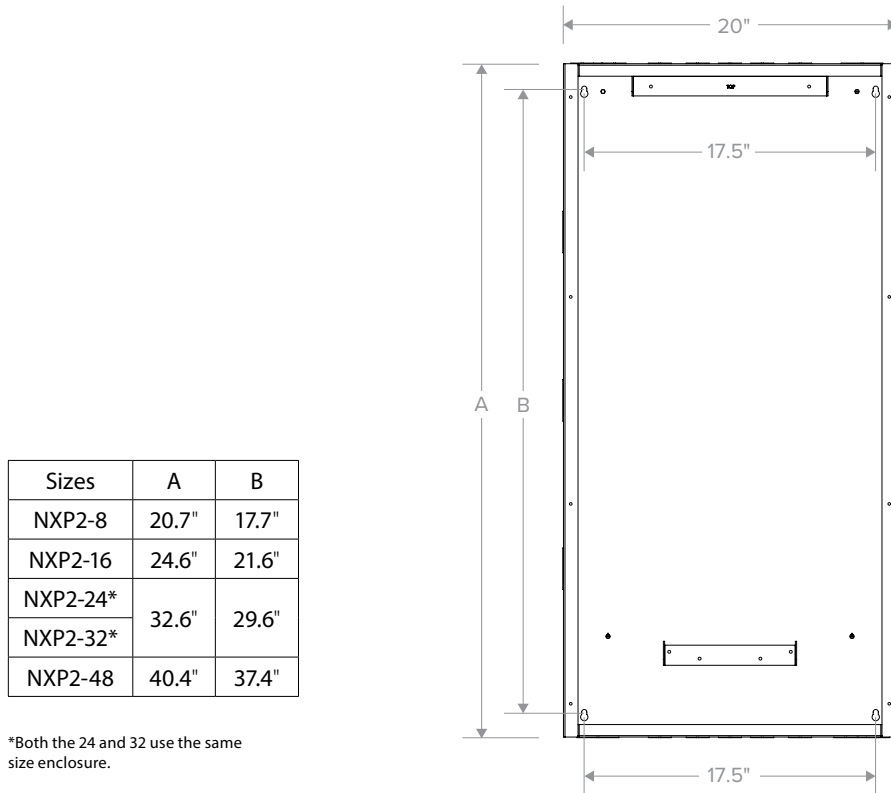

Figure 2: Different panel tub enclosure sizes with dimensions and mounting hole locations and distances between the mounting holes

INSTALLING INDIVIDUAL RELAYS

The NX Panel can be configured with single and/or double pole mechanically latching relays pre-installed. If the project requires additional relays (and space is available in the panel), additional relays can be field installed as shown in Figure 3.

CAUTION! ALWAYS REMOVE POWER FROM THE NX PANEL'S TRANSFORMER PRIOR TO MAKING ANY ELECTRICAL CONNECTIONS INSIDE THE PANEL. FAILURE TO DO SO MAY RESULT IN PERSONAL INJURY, DAMAGE TO THE PANEL, AND VOID ITS WARRANTY.

1. Verify that power is turned off at breaker panel before installing relay in panel.
2. Locate an open relay position (two adjacent positions for a double pole relay) in the panel and remove the relay guard cover(s).
3. Insert relay into mounting bracket noting proper orientation of input/output sides. Verify that relay is securely held in mounting bracket.
4. Connect relay input and output as shown in the wiring diagram below. Connect input to panel I/O control card using relay connector cable. Attach red lead to red screw and blue lead to blue screw. Slide connector on to header pins of I/O control card. Connect line and load leads to relay output.

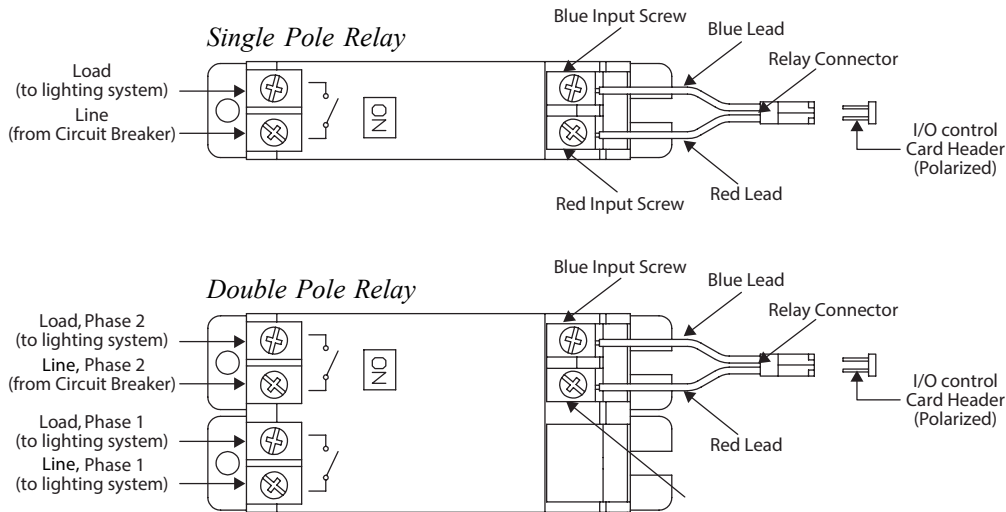

Figure 3: Relay Wiring Diagrams

5. If necessary, reinstall relay guard covers over open relay positions.
NOTE: Replacement single position relay guard covers are sold separately.
6. Reapply power to panel.
7. Verify relay operation by manually switching relay on and off using the manual control switch located on the relay.

CONNECTING PANEL POWER

The NX Panel has been configured to support one of the following input voltage configurations:

Input Voltage Part Number Code	Input Voltage
UNV	Universal Voltage (120/277VAC)
347	347VAC
480	480VAC

Panel input power is supplied to the power supply located in the upper section of the panel as shown in Figure 1. With the power turned off, route the dedicated panel power supply leads and connect them to the appropriate system voltage specific leads of the power supply. Connect the power supply ground lead to the panel chassis grounding lug. A label indicating this ground lug is located adjacent to the connection location.

NOTE: If the panel will be controlling emergency circuits, the panel power supply feed must be connected to a source of normal power. For more information on controlling emergency circuits, see section: USING THE NX PANEL FOR CONTROL OF EMERGENCY LIGHTING.

CONNECTING LIGHTING LOADS

With the power turned off, route the lighting system line and load leads through the high voltage area of the panel as shown in Figure 1. Connect line and load leads for each lighting load to the output terminals of the appropriate relay as delineated in the project plans and/or Panel Load Schedule.

NOTE: The panel may be shipped with relays installed and electrically connected at their input control side. If, however, relays must be installed, reference INSTALLING INDIVIDUAL RELAYS or the Relay Installation Instructions supplied with the individual Relays on how to install relays.

CAUTION! Prior to making any connections to the relay outputs, verify that none of the loads are shorted. Failure to do so may result in personnel injury, damage to the panel, and void its warranty.

USING THE NX PANEL FOR CONTROL OF EMERGENCY LIGHTING

The NX Panel's optional UL924 support comes pre-installed at the factory. When installed, the NX Panel is suitable for control of emergency lighting circuits. Upon loss of normal power, all relays will automatically go to the closed (ON) position and all dimming channels will go to 100% light output. NOTE: Connected devices will not be powered, and wireless control of the panel will be disabled.

Upon restoration of normal power to the panel's power supply, the relays will maintain their ON state until the relays and dimming channels return to their appropriate ON/OFF and dim states as determined by the panel's programming logic.

For more information about the NX Panel's optional UL924 (Available Q2-2021) support, see the NX Lighting Control Panel UL924 Operating Instructions (Available Q2-2021).

CONNECTING NX DEVICES

The NX Panel features (4) NX SmartPORTs™ for connecting NX switch, sensors and accessories as shown in Figure 1A.

NOTE: Support for direct connection of NX actuators (e.g. Room Controllers, Fixture Modules), Bridges and Radio Modules onto the Panel's SmartPORTs is not supported.

CONNECTING LOW VOLTAGE INPUTS & DRY CONTACT OUTPUTS

The NX Panel features (4) 3-wire low voltage auxiliary inputs as shown in Figure 1A. Low voltage inputs support momentary or maintained inputs from building automation, fire safety, demand response and security as well as other systems or low voltage devices.

Bring low voltage wiring for the contact inputs through the knockouts in the low voltage wiring area where indicated in Figure 1. Connect contact closure input devices to the input terminal block headers using 18 AWG wire. Each input provides a connection for sourcing 24V, a common, control and pilot light functionality for NX Lighting Controls Low Voltage Switch Stations. Each panel Input is software configurable to support low voltage momentary and maintained switches (latching), legacy (non-NX) motion sensors, or photocells. Each input can be individually programmed to initiate any NX switch compatible function or command. See Figure 4 for Low Voltage Input Wiring Diagrams.

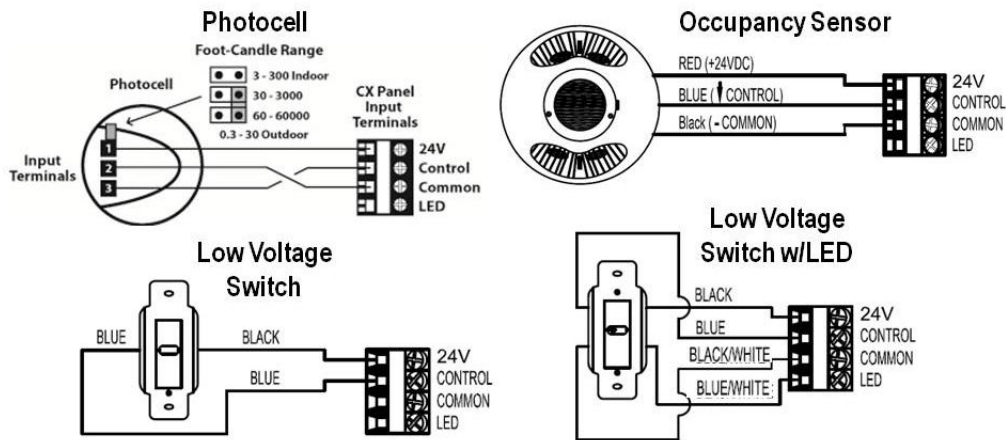

Figure 4: Low Voltage Input Wiring Diagrams

The NX Panel also features (2) SPDT (Normally Open/Normally Closed) dry contact outputs, as shown in Figure 1A, to support connection to building automation, security, fire safety or other building systems. Connect contact closure output devices to the output terminal block headers using 18 AWG wire. Each output has a contact rating of 24VDC @ 50mA minimum.

CONNECTING TO PANEL USING NX LIGHTING CONTROLS MOBILE APP AND NX BLUETOOTH® RADIO BRIDGE WITH REAL TIME CLOCK

The NX Panel is designed to operate as a standalone panel that can be programmed using a NX Bluetooth Radio Bridge with Real Time Clock and the NX Lighting Controls mobile app available in Android™ and IOS® version for free download from Google Play™ or the Apple® App Store.

1. Download the NX Lighting Controls mobile app Quick Start User Guide.
2. Plug NX Bluetooth Radio Bridge into one of the panel's SmartPORTs™.
3. From the NX Lighting Controls mobile app, select NX Setup. A page will be shown showing all the NX Bluetooth devices that are in range.
4. Select the panel. Once a Bluetooth connection has been made, the app will display a list of the connected relays, dimmers and devices that are available for programming.
5. Program devices and schedules according to the NX Lighting Controls mobile app Quick Start User Guide.

CONNECTING PANEL TO NX LIGHTING CONTROLS NETWORK

The NX Panel is designed to operate as a standalone panel or as a connected device on the NX Lighting Control System. The NX Lighting Controls network is Ethernet compatible with the exception that the Cat5 cable carries 24VDC as an integral power source for certain NX peripheral devices.

CAUTION! NEVER PLUG A POWERED NETWORK CABLE DIRECTLY INTO A PC/LAPTOP OR OTHER ETHERNET DEVICE.

NX Lighting Controls offers accessory devices that allow NX Networked to be converted to standard Ethernet or Ethernet to be converted back to NX Networked. Contact technical support for additional information.

The network interface in the panel is configured to provide an IN and OUT connection point for the NX Lighting Controls network. This allows a single daisy chain connection of panels and other network devices, minimizing the amount of Cat5 wire required to connect devices to the network.

1. Connect inbound Cat5 cable from the Area Controller or NX Bridge into the Non-Powered RJ45 connector on the panel's controller board.
2. Connect outbound Cat5 cable into the Powered RJ45 connector on the controller board to an NX Bridge device interface board of the first panel to the Non-Powered RJ45 connector in the next panel 3. Continue to run the network until all network bridge devices are connected.

IMPORTANT: Route the network so that there is no more than 100 meters (330 feet) of Cat5 wire between any two network devices.

NOTE: Consult the factory if the installation requires a longer wire run than 100 meters between devices.

3. With the panel powered, check to be sure there is an amber LED (link light) adjacent to each RJ45 connector. If the link light is not lit, confirm the installation of the RJ45 connectors on the cables using a proper testing device.

CAUTION: Never attempt to splice Cat5 cable. Use only proper industry accepted means to extend or join Cat5 ethernet network cable runs.

TROUBLESHOOTING

The panel's controller and relay/dimmer boards feature the following LED status indicators:

Controller Board:

- Power LED: Constant green when panel is powered
- Heartbeat LED: Normal panel operation = Flashes green every second; Panel bootup = Flashes green quickly
- Status LED: Flashes amber when communicating to relay/dimmer board(s)
- NX Networked Ethernet Ports:
 - Link+Activity LED (Green)
 - Off = No link (no connection to another network device detected)
 - On = Link established to another network device, no activity
 - Flashing = Link established to another network device, activity

72-00668G

- NX Networked Ethernet Ports (Continued):
 - Speed LED (Yellow)
 - Off = 10Mbit connection
 - On = 100Mbit connection
- Low Voltage Input LEDs (Red)
 - Closed = On
 - Open = Off
- Dry Contact Output LEDs (Green)
 - Closed = On
 - Open = Off

Relay/Dimmer Board:

- Heartbeat LED: Normal board operation = Flashes green every ½ second
- Status LED: Flashes amber when communicating with controller board

PANEL SPECIFICATIONS

CONSTRUCTION

Panel Enclosure:

- Exterior:
 - NEMA 1 Enclosure (Available In surface and flush mount versions)
 - (4) Keyhole mounting holes for mounting to wall
 - Standard electrical knockouts on top, bottom and sides for low voltage and line voltage feeds
 - Hinged locking door
- Interior:
 - Allows for installation of the exterior prior to the addition of the interior electrical components
 - (4) Keyhole mounting holes for mounting to panel exterior
 - Optional metal plate barrier available to separate relays (p/n NXP2-PBAR)

ELECTRICAL

Network Interface

- Ethernet 10 base-T via NX Lighting Controls network cable, integral 2-port Ethernet hub

Input Voltages

- UNV: 120/277VAC (50/60Hz)
- 347: 347VAC
- 480: 480VAC

Relay Operating Voltages

- Single Pole:
 - General Use: 30A @ 347VAC
 - Tungsten: 1920W @ 120VAC

ELECTRICAL (CONTINUED)

Relay Operating Voltages (Continued)

- Single Pole:
 - (Standard) Ballast: 10A @ 347VAC
 - Electronic Ballast: 16A @ 277VAC
 - Motor Starting: 1 HP @ 110-125VAC; 1.5HP @ 220-277VAC
 - Short Circuit Current Rating (SCCR) of 14,000A @ 277VAC

Relay Operating Voltages (Continued)

- Double Pole*:
 - General Use: 20A @ 347/480VAC
 - Tungsten: 2400W @ 120VAC
 - (Standard) Ballast: 20A @ 347/480VAC
 - Motor Starting: ½ HP @ 110-125VAC; 1.5 HP @ 220-277VAC
 - Short Circuit Current Rating (SCCR) of 5,000A @ 277VAC

Relay Electrical Ratings

- Rated for minimum 60,000+ operations (30,000+ cycles) at full 20A load
- Rated full-life with HID load

Relay Mechanical Ratings

- Rated for minimum 120,000+ operations (60,000+ cycles)

Dimming (0-10V) Ratings

- (8) Integrated dimming channels per Relay-Dimmer Board
- Each dimming channel capable of sinking 50mA
- Full support for Dim to Off drivers

ELECTRICAL (CONTINUED)

Class 2 Low Voltage NX SmartPORTs

- (4) NX SmartPORTs - 24VDC, 1.2A MAX (all outputs combined)
- Supports NX switches, sensors and accessories***
- RS485 digital communication

Class 2 Inputs / Outputs

- (4) 3-Wire dry contact inputs. Each input provides connect for sourcing 24VDC, common, control and switch pilot light functionality.
- (2) SPDT (Normally Open / Normally Closed) dry contact outputs. Each output rated for 24VDC @ 50mA.
- Terminal tolerance:
 - Wire size: 14, 16, 18, 20, 22 AWG
 - Recommended tightening torque: 0.45 N-m (4 in-lbs.)

Bluetooth®

- Bluetooth programming using the NX Lighting Controls mobile app requires the NX Radio Bridge with Real Time Clock (p/n NXBTC) - included

OPERATION

Programming and Configuration:

- Programmable via Bluetooth NX Lighting Controls mobile app (Android™ and IOS® version for free download from Google Play™ or the Apple® Store.)

*Double pole relays occupy (2) relay spaces
 **Requires NX Area Controller
 *** Connection of NX actuators, bridges and radios is not supported

PANEL SPECIFICATIONS (CONTINUED)

OPERATION (CONTINUED)

- Programmable via web-browser user interface**

OPERATING ENVIRONMENT

- Indoor use only
- 32° to 112°F (0° to 50°C)
- Relative humidity (non-condensing): 10% to 90%

CERTIFICATIONS

- UL 916, CAN/CSA C22.2 No. 205
- UL 924, CAN/CSA C22.2 No. 141 Emergency Lighting (UL924 Option Required)

WARRANTY

- 5 year limited warranty

PANEL LOAD SCHEDULE FORM

A Panel Load Schedule Form is supplied in the clear plastic pocket inside the Panel Door to record the lighting circuit relay assignments while connecting the relays. Low voltage input/output types and assignments should also be recorded on the form.

WIRING DIAGRAMS

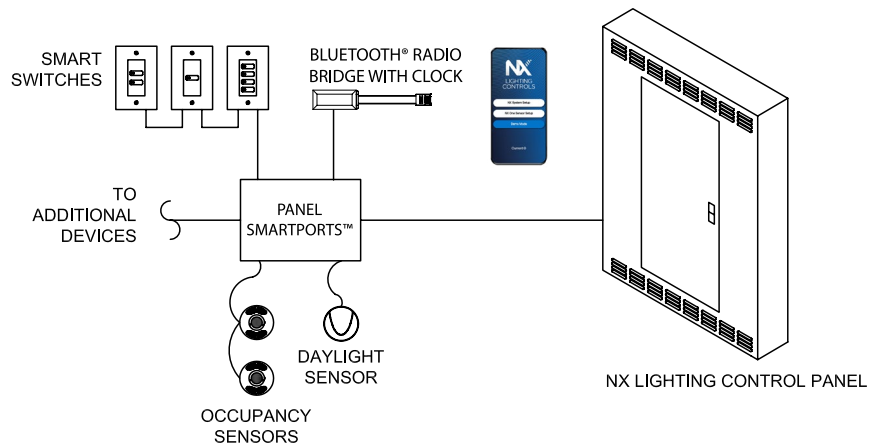

Standalone Panel Programmed Using Bluetooth Radio Bridge with Clock and NX Lighting Controls mobile app

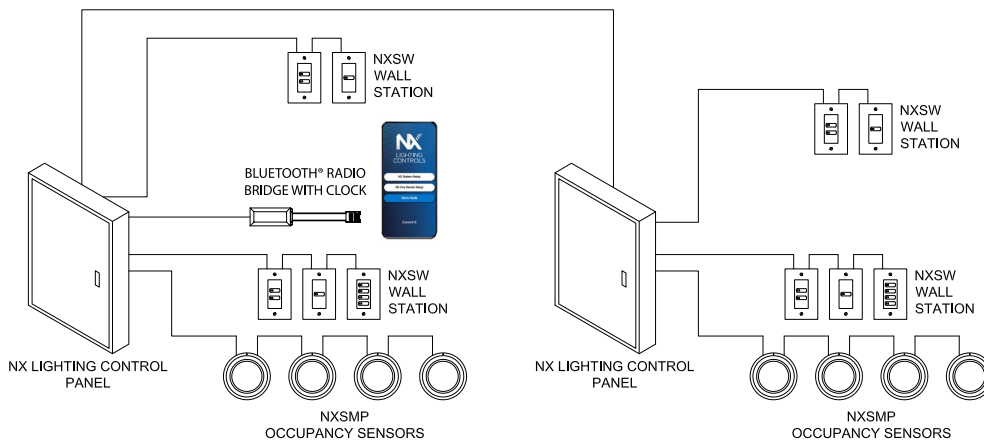

Networked Panels Programmed Using Bluetooth Radio Bridge with Clock and NX Lighting Controls mobile app

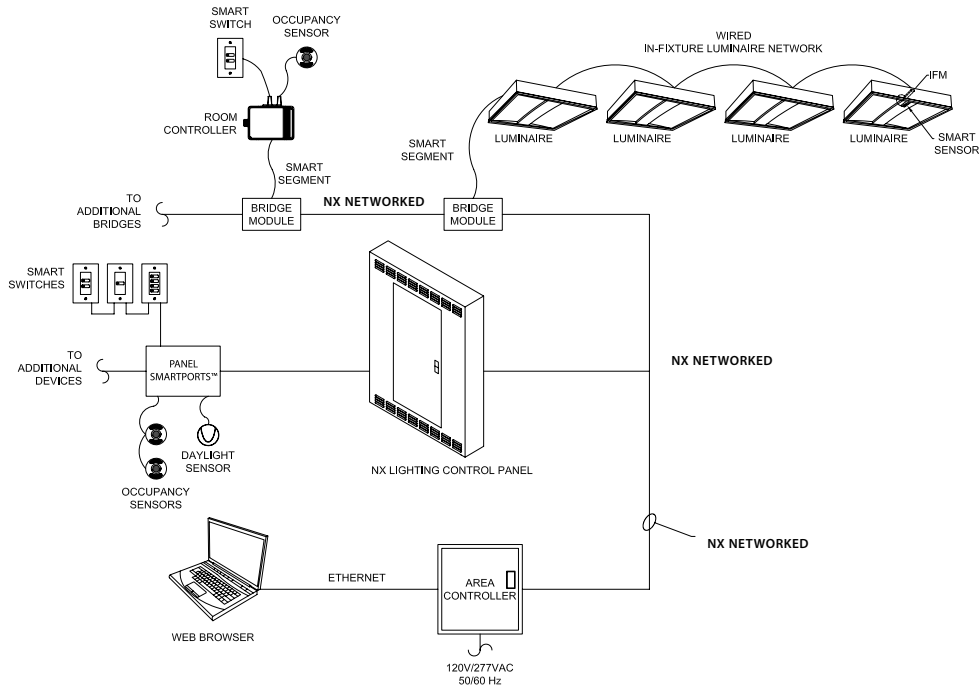

Networked Panel Programmed Using the NX Area Controller

BATTERY STATEMENT

Remove and immediately recycle or dispose of used batteries according to local regulations and keep away from children. Do NOT dispose of batteries in household trash or incinerate. Even used batteries may cause severe injury or death. Call a local poison control center for treatment information.

Battery used in device is a BR2032 or CR2032 3V battery. Battery is non-rechargeable. Non-rechargeable batteries are not to be recharged. Do not force discharge, recharge, disassemble, heat above +70°C or incinerate. Doing so may result in injury due to venting, leakage or explosion resulting in chemical burns.

Ensure batteries are installed correctly according to polarity (+ and -). Do not mix old and new batteries, different brands or types of batteries, such as alkaline, carbon-zinc, or rechargeable batteries. Remove and immediately recycle or dispose of batteries from equipment not used for an extended period of time according to local regulations. Always completely secure the battery compartment. If the battery compartment does not close securely, stop using the product, remove the batteries, and keep them away from children.

<h2 style="margin: 0;">WARNING</h2>	
<ul style="list-style-type: none"> • INGESTION HAZARD: This product contains a button cell or coin battery. • DEATH or serious injury can occur if ingested. • A swallowed button cell or coin battery can cause Internal Chemical Burns in as little as 2 hours. • KEEP new and used batteries OUT OF REACH OF CHILDREN. • Seek immediate medical attention if a battery is suspected to be swallowed or inserted inside any part of the body. 	