

MODEL NUMBERS

NXFM-LV

PRECAUTIONS

- Read and understand all instructions before beginning installation.
- NOTICE: For installation by a licensed electrician in accordance with National and/or local Electrical Codes and the following instructions.
- Disconnect switch or a circuit breaker must be provided and marked as the disconnecting device.
- Disconnect switch / circuit breaker must be within reach of operator.
- CAUTION: RISK OF ELECTRICAL SHOCK. Turn power off at service panel before beginning installation.
- Never wire energized electrical components.
- CAUTION: USE COPPER CONDUCTOR ONLY
- Confirm device ratings are suitable for application prior to installation. Use of device in applications beyond its specified ratings or in applications other than its intended use may cause an unsafe condition and will void manufacturer's warranty.
- NOTICE: Do not install if product appears to be damaged.

SAVE THESE INSTRUCTIONS!

DESCRIPTION

The NX Low Voltage Fixture Module is a self-contained intelligent controller designed specifically for installation within a light fixture. **The NXFM-LV module does not contain a relay for On/Off control of the fixture. The On/Off control is provided by “dim to off” functionality provided with the fixture.** The module provides two 0-10 volt dimming channels. One dimming channel is intended for continuous dimming of the fixtures light output. The second dimming channel can be used with compatible fixtures to provide “dim to warm” or “color tuning” control of the LEDs. A SmartPORT™ on the module allows connection of accessory devices such as Smart Sensors, Smart Switches, or RF radio module. The NXFM fixture module can operate stand-alone or as part of a networked configuration.

SPECIFICATIONS

Electrical Ratings	Input: 12 VDC
Control connection	Low Voltage SmartPORT
Dimming	0-10V, 30mA per channel
	For use with low-voltage, two-wire dimming ballast and LED drivers
Operating Environment:	Operating Temperature: -40°F to 185°F [-40°C to 85°C]
	Relative humidity (non-condensing): 0 to 95%
Construction	Housing: GSM UL Rated 94 HB Plastic
Mounting	Mounts inside fixture
Dimensions	3.65" L x 1.01" W x 0.69" H (92.59mm L x 24.65mm W x 17.60mm H)
Weigh:	1 oz (28.34 g)
Color:	Blue
Patents	Patent(s): Pending
Certifications:	Conforms with UL916 and Certified to CAN/CSA C22.2 No. 205-M1983
	IC Approved
Warranty:	Five-year limited

INSTALLATION

1. Choose an appropriate location within the fixture to mount the module. Using appropriate fasteners (not included) attach the module to the fixture.
2. Insert the purple dimming wire from the driver or ballast (this might be marked as PURPLE, POSITIVE, or +) into the push-in connector on the end of the module. IMPORTANT- use only solid or tinned wire with the push-in connector.
3. Insert the pink dimming wire from the driver or ballast (this might be marked as PINK, NEGATIVE, or -) into the push-in connector on the end of the module. IMPORTANT- use only solid or tinned wire with the push-in connector.

4. If the fixture is equipped for color control, insert the color control wire from the driver into the push-in connector on the end of the module. **IMPORTANT-** use only solid or tinned wire with the push-in connector.
5. Using the supplied cable, connect the NX Smart Sensor, NXDSP, NXFSP, or other NX accessory module to the four pin connector on the end of the NXFM-LV fixture module. Be sure to follow all instructions supplied with the NX Smart Sensor or NX accessory modules.
6. Dress and bind the wires keeping the line voltage wires separate from the dimming wires and any other cables or communication wires that might be in the fixture.
7. Apply power and test the assembly.

TEST THE OPERATION

The operation of the NXFM fixture module can be tested using the pushbutton and LED located on the top of the module housing.

1. Momentarily press and release the button. The LED will illuminate and the light will turn on.
2. While the LED is ON, press and hold the button. The dimming channel (purple wire) will dim down. Release the button, then press hold again. The light will dim up.
3. Release the button, then press and hold the button again. The color channel (purple with white stripe) will transition to WARM. Release the button, then press and hold the button again. The color will transition to COOL.
4. Momentarily press and release the button. The LED will extinguish and the light will turn off.

Note: The above sequence assumes that the fixture’s driver is configured for dim-to-off (turns off at minimum dimming level).

RESET THE MODULE BACK TO FACTORY DEFAULT

Use this procedure to reset the NXFM fixture module back to factory fresh settings and erase all user programming.

1. Begin with the LED OFF (see above).
2. Press and hold the button for ten seconds until the LED begins to flash in a three times per second pattern.
3. Release the button. When the flashing stops, the unit will be at factory fresh default settings.

DIMENSIONS

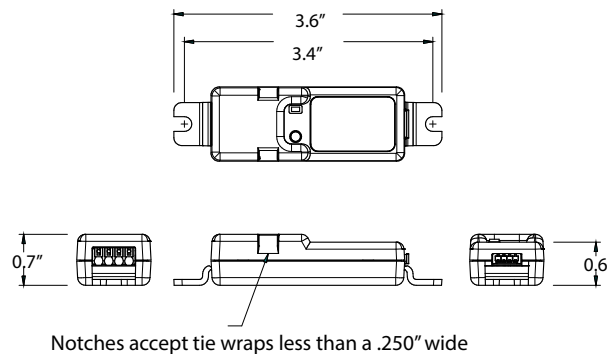

WIRING DIAGRAMS

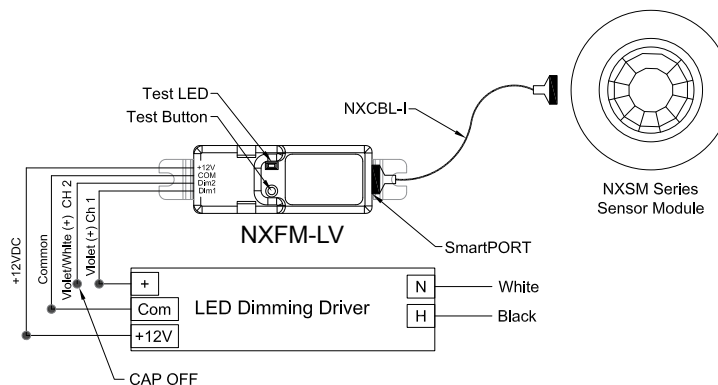

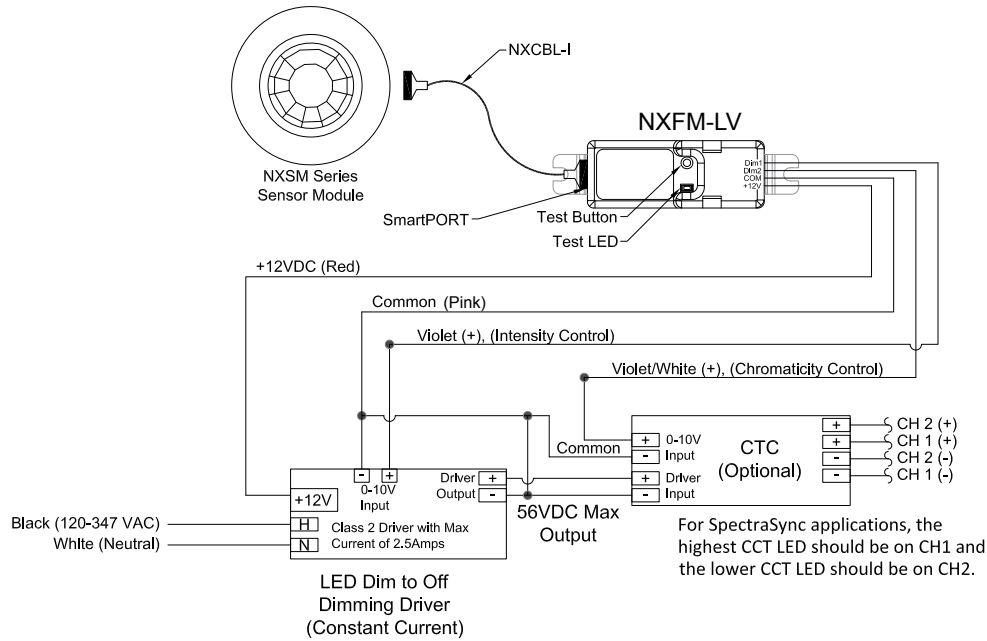

BATTERY STATEMENT

Remove and immediately recycle or dispose of used batteries according to local regulations and keep away from children. Do NOT dispose of batteries in household trash or incinerate. Even used batteries may cause severe injury or death. Call a local poison control center for treatment information.

Battery used in device is a MS412FE LITH VRT 3V 1mAh 4.8MM coin battery. Battery is not rechargeable and non-replaceable. Non-rechargeable batteries are not to be recharged.

Do not force discharge, recharge, disassemble, heat above +60°C or incinerate. Doing so may result in injury due to venting, leakage or explosion resulting in chemical burns.

<p>WARNING</p>	
<ul style="list-style-type: none"> • INGESTION HAZARD: This product contains a button cell or coin battery. • DEATH or serious injury can occur if ingested. • A swallowed button cell or coin battery can cause Internal Chemical Burns in as little as 2 hours. • KEEP new and used batteries OUT OF REACH OF CHILDREN. • Seek immediate medical attention if a battery is suspected to be swallowed or inserted inside any part of the body. 	