

INSTALLATION OVERVIEW

The installation instructions contained in this document are provided as a guide for proper and reliable installation and connection of the NX Lighting Control Panel V2 UL924 for control of emergency lighting.

These instructions include information as follows:

- Precautions
- Description
- Emergency Mode Operation
- LED Status Indicators
- Specifications

PRECAUTIONS

IMPORTANT SAFEGUARDS

When using electrical equipment, basic safety precautions should always be followed including the following:

READ AND FOLLOW ALL SAFETY INSTRUCTIONS.

- **CAUTION - RISK OF ELECTRICAL SHOCK.** To prevent electrical shock, turn off power at the circuit breaker before installing or servicing unit. Never wire energized electrical components.
- **NOTICE:** For installation by a licensed electrician in accordance with national and/or local Electrical Codes and the following instructions.
- **CAUTION: USE COPPER CONDUCTOR ONLY.**
- **CAUTION: This equipment provides more than one power supply output source. To reduce the risk of electric shock disconnect both normal and emergency sources within this unit before servicing any equipment connected to this unit.**
- Be sure to read and understand all instructions before installing or servicing unit.
- For Indoor use only. Do not use outdoors.
- Do not install near gas or electric heaters.
- The use of accessory equipment not recommended by the manufacturer may cause an unsafe condition.
- Confirm that device ratings are suitable for application prior to installation.
- Equipment should be mounted in locations and at heights where it will not readily be subjected to tampering by unauthorized personnel.
- Use only approved materials and components (i.e. twist on connectors, electrical box, etc.) as appropriate for installation.
- **NOTICE:** Do not install if product appears to be damaged.
- If the equipment is used in a manner not specified by the manufacturer, the protection provided by the equipment may be impaired.
- Do not use this equipment for other than intended use.

SAVE THESE INSTRUCTIONS!

DESCRIPTION

The NX Panel is a configurable lighting control panel consisting of single and/or double pole relays, 0-10V dimming channels, low voltage inputs, dry contact outputs, NX SmartPORTs™ for NX Occupancy Sensors, Daylight Sensors and Smart Wall Stations, and an optional UL924 Emergency Interface. Panels can be configured with all relays of the same type installed or with space available for relays to be installed in the field. The relays are mounted with lighting circuit terminals in the high voltage area. The low voltage control inputs/outputs are in the low voltage area of the panel. See Figure 1.

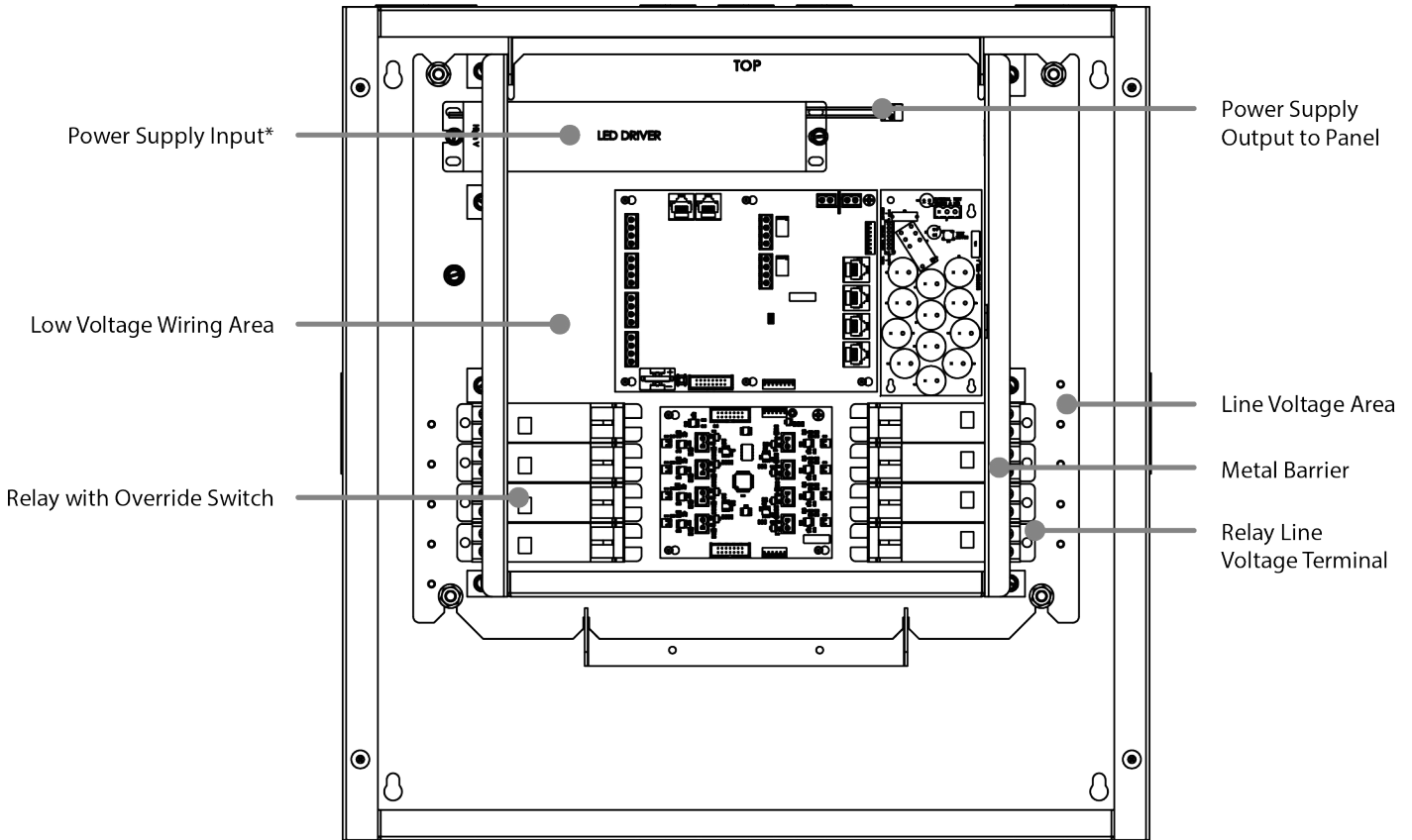

*Connect to normal power source if panel is controlling emergency circuits.

Figure 1: Fully populated 16 relay interior with UL924 board mounted in the exterior enclosure

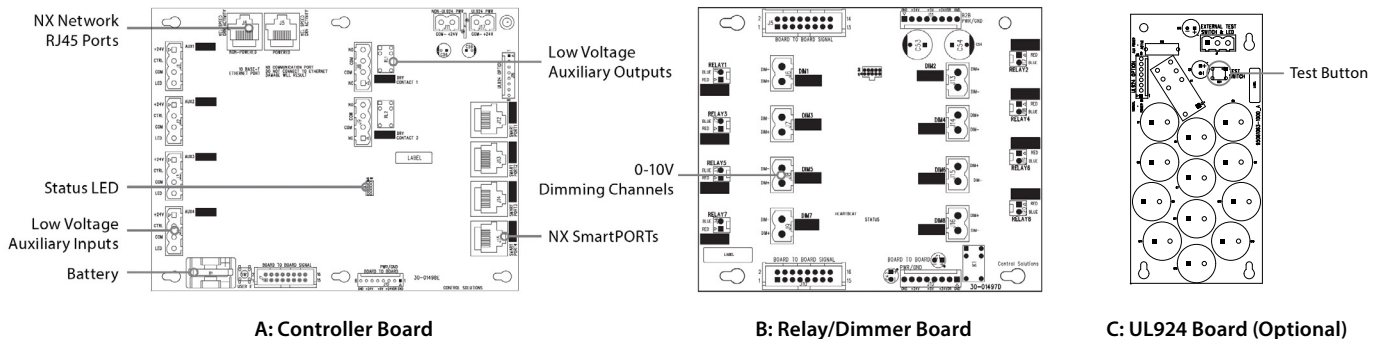

A: Controller Board

B: Relay/Dimmer Board

C: UL924 Board (Optional)

The NX Panel's optional UL924 circuit board is pre-installed at the factory (NOTE: Field installation is not supported). When installed, the NX Panel is suitable for control of emergency lighting circuits. Upon loss of normal power, all relays will automatically go to the closed (ON) position and all dimming channels will go to 100% light output. This state will be maintained until normal power is restored.

NOTE: Connected devices will not be powered, and wireless control of the panel will be disabled.

The NX Panel's internal control system is powered by a 24V supply that is connected to the normal power source as shown in Figure 2. When normal power is present, the system is powered and all relays and dimming channels can be individually controlled as desired. If normal power is lost, the UL924 circuit board switches all the relays to the on position. Switching the relays to the on position allows the emergency transfer switch to power selected loads.

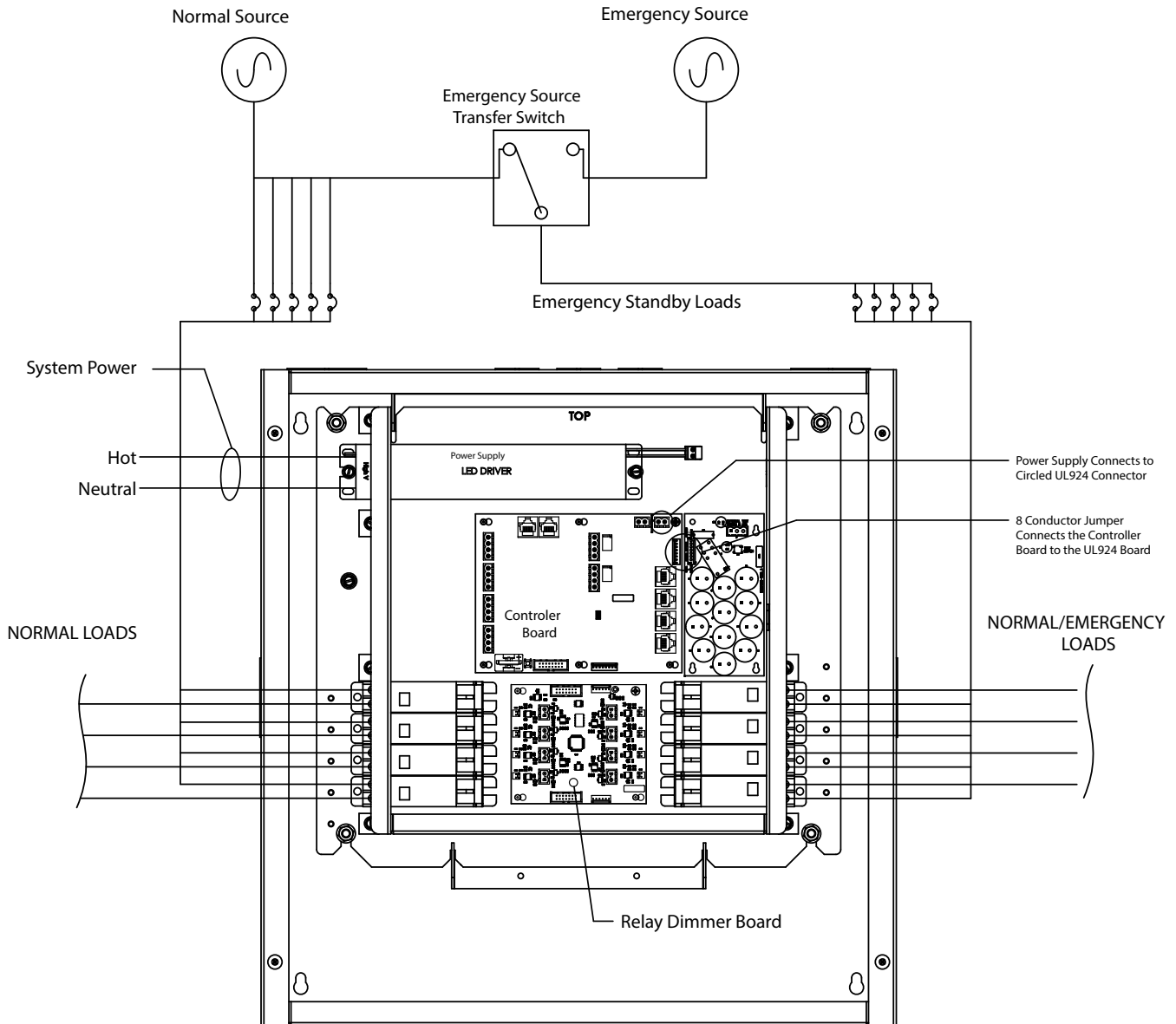

Figure 2: Panel Wiring Connections For Normal And Emergency Power

INSTALLING

The UL924 option consists of:

- (1) UL924 Circuit Board
- (1) 8 Conductor Between Board Connector

CAUTION! ALWAYS REMOVE POWER FROM THE NX PANEL'S TRANSFORMER PRIOR TO MAKING ANY ELECTRICAL CONNECTIONS INSIDE THE PANEL. FAILURE TO DO SO MAY RESULT IN PERSONAL INJURY, DAMAGE TO THE PANEL, AND VOID ITS WARRANTY.

EMERGENCY MODE OPERATION

When normal power is lost and the panel enters emergency mode, the following will occur:

- All relays will be forced to the ON position and not allowed to be switched to the OFF position unless the manual override on the relay is used. Any relay that has its contacts connected to emergency power will provide the emergency power to that load.

NOTE: The NX Panel does not supply power to the emergency lighting. The panel only makes sure the relay(s) driving the emergency lighting loads(s) are switched on. Emergency power is supplied to the lighting loads through the emergency transfer switch as shown in Figure 2.

- All dimming channels will be forced to full output.

NOTE: Once the power is depleted from the capacitors used to control the relays to the on position all LED indicators will no longer be on. Once power is restored the capacitors will fully recharge within 10 seconds.

Upon restoration of normal power to the panel's power supply, the relays will maintain their ON state until the relays and dimming channels return to their appropriate ON/OFF and dim states as determined by the panel's programming logic.

UL924 LED STATUS INDICATORS

The UL924 circuit board features several LED status indicators: to determine the status of the panel:

- NORMAL POWER ON (Red LED): ON = Normal Power ON, OFF = Normal Power OFF
- AUX POWER ACTIVE (Red LED): ON = Indicates the power supply is on and keeping emergency supply ready for power loss. OFF= Currently in emergency mode or failure with 924 board during power good condition.

TESTING

The UL924 circuit board also features an internal test switch and external test switch/LED connector. Pressing and holding the test switch or activating the external test switch manually puts the panel into emergency mode. Releasing the internal test switch or external test switch returns the panel to normal operation.

SPECIFICATIONS

OPERATING ENVIRONMENT

- Indoor use only
- 32° to 112°F (0° to 50°C)
- Relative humidity (non-condensing): 10% to 90%

WARRANTY

- 5 year limited warranty

BATTERY STATEMENT

Remove and immediately recycle or dispose of used batteries according to local regulations and keep away from children. Do NOT dispose of batteries in household trash or incinerate. Even used batteries may cause severe injury or death. Call a local poison control center for treatment information.

Battery used in device is a BR2032 or CR2032 3V battery. Battery is non-rechargeable. Non-rechargeable batteries are not to be recharged. Do not force discharge, recharge, disassemble, heat above +70°C or incinerate. Doing so may result in injury due to venting, leakage or explosion resulting in chemical burns.

Ensure batteries are installed correctly according to polarity (+ and -). Do not mix old and new batteries, different brands or types of batteries, such as alkaline, carbon-zinc, or rechargeable batteries. Remove and immediately recycle or dispose of batteries from equipment not used for an extended period of time according to local regulations. Always completely secure the battery compartment. If the battery compartment does not close securely, stop using the product, remove the batteries, and keep them away from children.

 WARNING	
<ul style="list-style-type: none"> • INGESTION HAZARD: This product contains a button cell or coin battery. • DEATH or serious injury can occur if ingested. • A swallowed button cell or coin battery can cause Internal Chemical Burns in as little as 2 hours. • KEEP new and used batteries OUT OF REACH OF CHILDREN. • Seek immediate medical attention if a battery is suspected to be swallowed or inserted inside any part of the body. 	