

IMPORTANT SAFEGUARDS
READ AND FOLLOW ALL SAFETY INSTRUCTIONS

PRECAUTIONS

When using electrical equipment, basic safety precautions should always be followed including the following:

Read and understand all instructions before beginning installation.

NOTICE: For installation by a licensed electrician in accordance with National and/or Local Electrical Codes and the provided following instructions.

CAUTION: RISK OF ELECTRICAL SHOCK. Turn power off at service panel before beginning installation of device. Never wire energized electrical components.

Disconnect switch or a circuit breaker must be provided and marked as the disconnecting device.

Disconnect switch / circuit breaker must be within reach of operator.

CAUTION: USE COPPER CONDUCTOR ONLY.

Confirm device ratings are suitable for application prior to installation. Use of device in applications beyond its specified ratings or in applications other than its intended use may cause an unsafe condition and will void manufacturer's warranty.

NOTICE: DO NOT INSTALL IF PRODUCT APPEARS TO BE DAMAGED.

NOTICE: Do not use outdoors.

NOTICE: Do not mount near gas or electric heaters.

NOTICE: Do not use this equipment for other than its intended use.

SAVE THESE INSTRUCTIONS AND PROVIDE TO OWNER AFTER INSTALLATION IS COMPLETED

DESCRIPTION

Current Lighting Controls' NXFRD 0-10V Dimming Converter allows for a 0-10V interface to be used to control Reverse and Forward Phase Dimming circuits in conjunction with a NXRCFX Room Controller. The NXFRD is auto-sensing and will automatically recognize the load type and set the unit to either Forward or Reverse Phase Dimming.

SPECIFICATIONS
CONSTRUCTION

- Housing: Anodized Aluminum
- Color: Black
- 28 oz (798g)
- 4.01" (101.85MM)L x 5.52"(140.22MM)W x 1.88" (47.75MM)H
- Complies with requirements for use in a plenum area

MOUNTING

- Surface Mount with Screws (Screws not provided)

ELECTRICAL

- Input
 - 120/277VAC, 60Hz
 - Single Feed Input Connection
- Output
 - 120/277VAC, 60Hz
 - Single Feed Output Connection
- Low Voltage
 - Class 2 0–10V Input and Output

ELECTRICAL (CONTINUED)

- Max Load Rating
 - 120VAC - 700W
 - 277VAC - 1300W
- Minimum Load Rating
 - 24W Minimum
- Standby Power
 - 120VAC: 0.75W
 - 270VAC: 1.87W
- Dimming
 - Class 2/Class 1
 - Installation as Class 1 requires 600 volt insulation on dimming conductors sharing a conduit with line voltage conductors

OPERATING ENVIRONMENT

- Operating Temperature: -40°F to 140°F (-40°C to 60°C)
- Relative Humidity (Non-condensing): 0% to 50%

CERTIFICATIONS

- ETL Damp Locationse

WARRANTY

- 5 year limited warranty

INSTALLATION

1. Turn off power at the service panel before beginning installation.
2. Mount the NXFRD securely to a solid surface using the slotted wings located on the sides of the housing. Secure to surface using screws (not provided).
3. Following the applicable wiring diagram provided in Figure 1, first connect your desired lighting load to be controlled to the side of the device labeled LOAD. Ensure to connect appropriate wires or Line (Black), Neutral (White), and Ground (Green) on the provided flexible conduit.

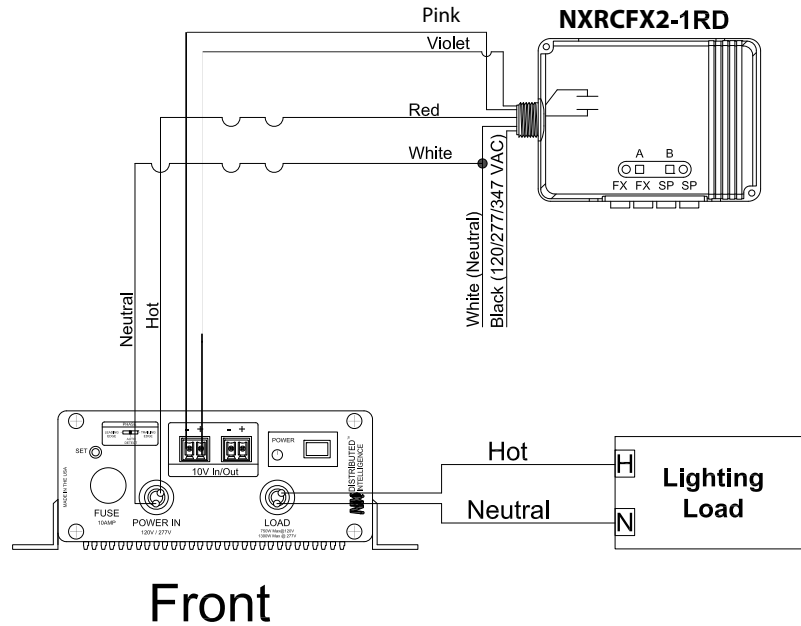

FIGURE 1: Wiring Diagram to Room Controller

4. Next connect your input line voltage to the side of the device labeled POWER IN. Ensure to connect appropriate wires or Line (Black), Neutral (White), and Ground (Green) on the provided flexible conduit.
5. After connecting power for both POWER IN and LOAD, connect the low voltage violet and pink dimming wires to the CONTROL INPUT at the top of the device. Be sure to place your signal input from the NXRCFX (Or other 0-10V Device) to the ports labeled IN-10V.
6. If you are using multiple NXFRD with a single 0-10V signal, you can daisy chain multiple units using the port labeled OUT-10V. See Figure 2.
7. This unit is auto sensing and will automatically detect and set the unit to either Leading Edge (Forward Phase) or Trailing Edge (Reverse Phase) Dimming. The unit has been calibrated to recognize a wide array of load types and will respond accordingly. There is not ability to manually set the mode and is default to AUTO.

"Pink wire replaces previous gray wire. Units with a gray instead of pink wire should be wired as the pink wire shown in the diagram."

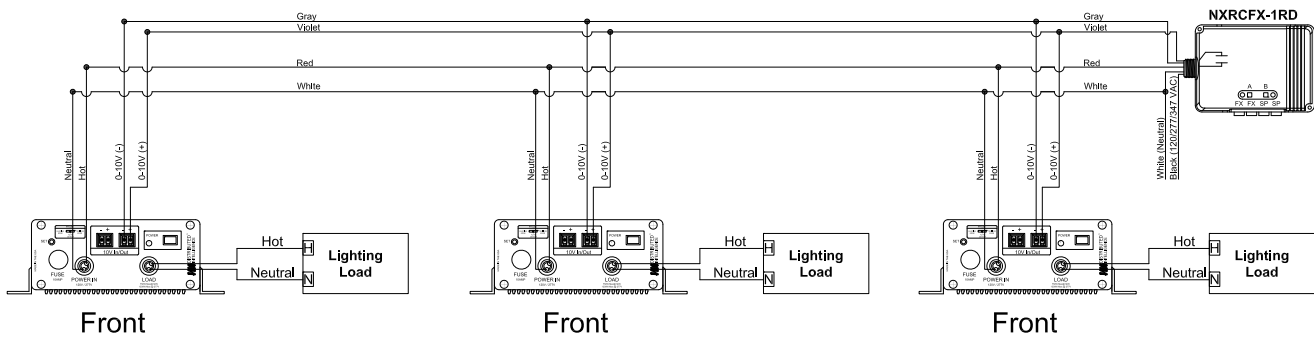

FIGURE 2: Wiring Diagram to multiple NXFRD

8. Once wiring is complete reapply power at the service panel.
9. After power is restored press the POWER button located on the top right of the device. Before proceeding verify the device is in the On position for power.
10. Once power is applied dim the fixtures to the desired minimum intensity and press "SET" to set the current intensity as the minimum.
NOTE: To reset the value, dim the 0-10V signal from the input device to the lowest setting and press the SET button again to set a new intensity.

"Pink wire replaces previous gray wire. Units with a gray instead of pink wire should be wired as the pink wire shown in the diagram."