

INSTALLATION  
INSTRUCTIONS

FIXTURE TYPE \_\_\_\_\_

EXTENSION KIT (SE AND ASE)  
WALLSLOT 2000 & L20

P/C 510259-3000

PG. 1 OF 1

DO NOT MODIFY OR ALTER THIS PRODUCT IN ANY WAY, OR INSTALL IN ANY FASHION WHICH IS CONTRARY TO THE INSTRUCTIONS CONTAINED HEREIN. IF YOU HAVE ANY QUESTIONS REGARDING THIS PRODUCT OR THE INSTALLATION OF IT, PLEASE CALL LITECONTROL ENGINEERING AT 781-294-0100.

GENERAL NOTES:

- A) SUPPORT RAILS, PLENUM COVERS AND FIXTURES (SHIPPED SEPARATELY) MUST BE INSTALLED PRIOR TO MOUNTING EXTENSION KITS.
- B) REFER TO INSTRUCTION SHEETS 510573, 510261 AND 510258 FOR THE ABOVE.
- C) USE THE FOAM WRAP PACKAGING TO PROTECT FINISH OF PARTS DURING FIELD CUTTING.

INSTRUCTIONS:

1. MEASURE CEILING OPENING (DIM "X") AND CUT THE SE SHIELD AND CEILING TRIM TO MATCH THIS LENGTH. NOTE: FOR ASE SHIELD, ADD 9 1/4" TO DIM "X" AND CUT. FOR ASE CEILING TRIM, ADD 10 3/4" TO DIM "X" AND CUT THE NON-MITRED END: USE THE BENCHMARK EDGE SHOWN IN VIEW "A" FOR LOCATING THE FIELD CUT DIMENSION.
2. CUT ENDS OF THE U-ANGLE AND FILLER PLATE TO DIM "X" MINUS 1/8" FOR SE: FOR ASE U-ANGLE AND FILLER PLATE ADD 9 1/4" TO DIM "X" AND CUT.
3. SNAP PLUG BUTTON INTO 7/8" HOLE IN END HEADER IF WIRE FEED IS NOT BROUGHT IN AT THIS END.
4. ATTACH JOINER STRAP MOUNTING ANGLE TO PLENUM COVER ON ROOM SIDE OF FIXTURE WITH 1/4-20 SCREWS AND HEX NUTS
5. SLIDE JOINER STRAP INSIDE THE ENDS OF THE U-ANGLE AND LIFT INTO CEILING OPENING. ON WALL SIDE USE SCREWS AND HEX NUTS TO "SANDWICH" PLENUM COVER'S END FORM BETWEEN JOINER STRAP MOUNTING ANGLE AND JOINER STRAP. LEVEL U-ANGLE AND NAIL OR SCREW OPPOSITE END TO WALL. PRESS U-CLIPS OVER JOINER STRAP AND ENDS OF U-ANGLE: SEE VIEWS "A" AND "C".
6. TUCK THE TRIMMED EDGE OF THE FILLER PLATE INTO BOTTOM FLANGE OF THE JOINER STRAP AND SECURE TO BOTTOM OF U-ANGLE WITH NYLON DART FASTENERS.
7. SLIDE SHIELD INTO GROOVE ON CEILING TRIM (NOTE POSITION OF TRIMMED EDGES). ALIGN EDGE OF SHIELD WITH END OF CEILING TRIM AND SECURE WITH (2 MIN) 1/4" LG. SHEET METAL SCREWS AS SHOWN.
8. SLIDE CORNER SPLINE INTO END OF CEILING TRIM AS SHOWN.
9. LIFT SHIELD/CEILING TRIM INTO OPENING ABUTTING THE ADJACENT FIXTURE. ATTACH SHIELD TO U-ANGLE WITH (2) NYLON DART FASTENERS. SLIDE FIXTURE SPLINE INTO CEILING TRIM ALIGNING THE JOINT: SECURE WITH (4) 1/4" LONG SHEET METAL SCREWS: SEE VIEW "B".
10. SLIDE CORNER SPLINE UP AGAINST ABUTTING WALL AND NAIL OR SCREW INTO POSITION. FASTEN CORNER SPLINE TO CEILING TRIM WITH A SHEET METAL SCREW AS SHOWN.

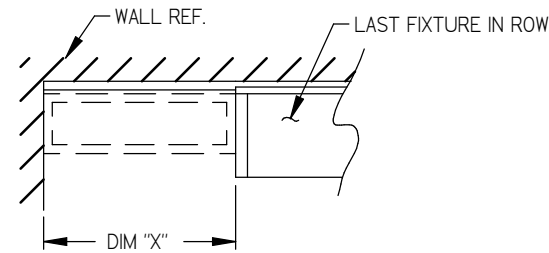
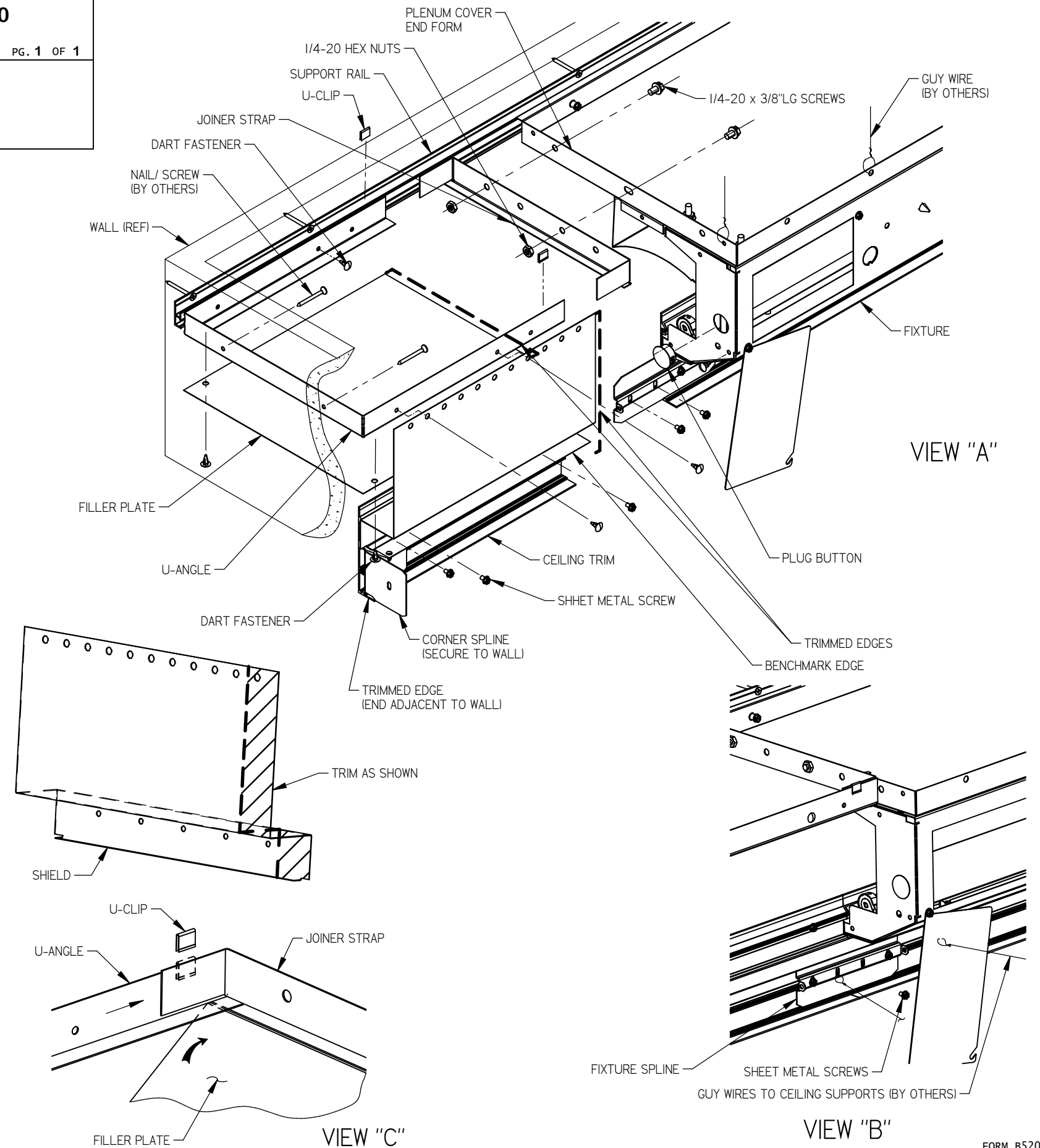

SE

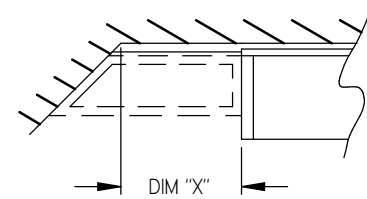

ASE