

**GENERAL NOTES: (READ SHEETS COMPLETELY BEFORE STARTING)**

1. LEAVE PROTECTIVE WRAPPING ON FIXTURE(S) UNTIL START OF INSTALLATION.
2. REFER TO SUPPLEMENTAL WIRING INSTRUCTION SHEET 510401 WHEN MAKING WIRING CONNECTIONS.
3. APPROXIMATE WEIGHT OF FIXTURE IS 2 LBS PER FOOT OF LENGTH.
4. FEED CORDS ARE FACTORY INSTALLED ON INDIVIDUAL FIXTURES. FOR ROW MOUNTED FIXTURES, FEED CORD IS FACTORY INSTALLED AT END OF ROW LEFT (EORL) FIXTURE ONLY. IF ADDITIONAL FEED CORDS ARE REQUIRED FOR THE ROW, THEY WILL BE SUPPLIED BY LITECONTROL BUT FIELD INSTALLED BY CONTRACTOR.

**TOOLS REQUIRED**

- SCREWDRIVER/DRILL
- 1 1/32" NUT DRIVER

**SUPPLIED BY INSTALLER**

1

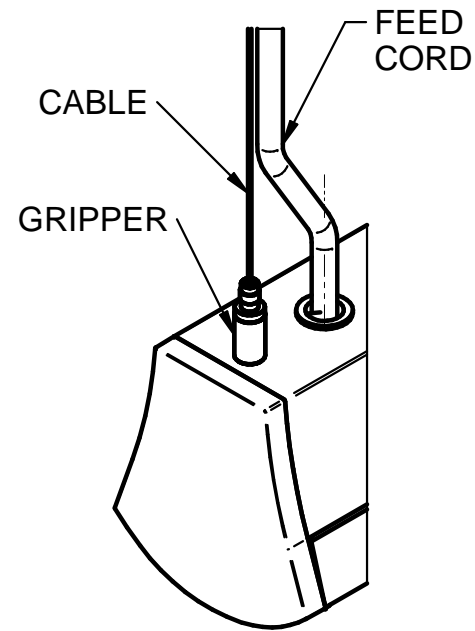

FOR INDIVIDUAL FIXTURE, LIFT FIXTURE UP TO THE AIR CRAFT CABLES AND PASS THE CABLES THROUGH THE GRIPPERS. LEVEL FIXTURE BY ADJUSTING GRIPPER UP OR DOWN. REFER TO CABLE INSTRUCTION SHEET 510541.  
FOR ROW MOUNTED FIXTURES, PERFORM THIS STEP AND PROCEED TO STEP 2.

2

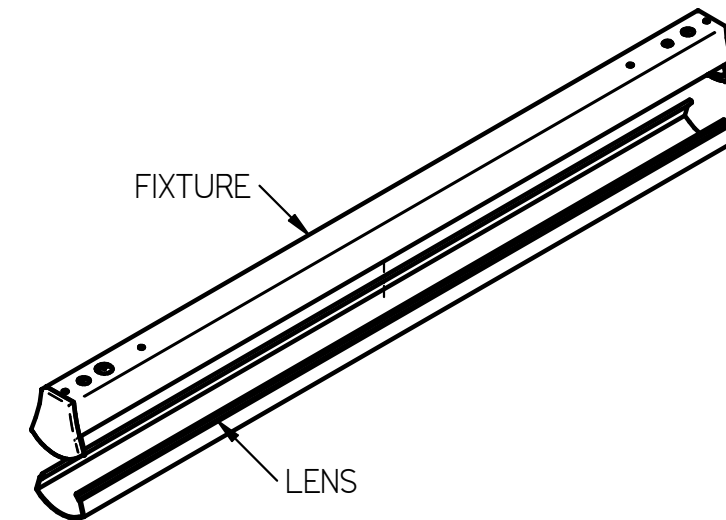

TO REMOVE LENS, START AT ONE END OF FIXTURE, GENTLY SQUEEZE SIDES OF LENS. MOVING ALONG LENGTH OF FIXTURE, CONTINUE TO GENTLY SQUEEZE SIDES OF LENS, RELEASING LENS LIP FROM HOUSING, PIVOT LENS TO ONE SIDE. GENTLY WORK LENS OUT OF END HEADERS.

3

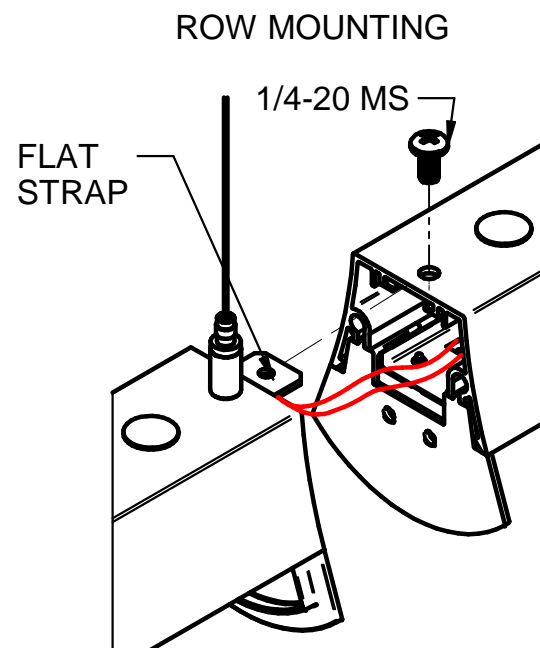

MOUNT THE NEXT FIXTURE IN ROW PER STEP 1. AT FIXTURE JOINT ALIGN AND INSERT PROTRUDING FLAT STRAP OF INTO ADJOINING FIXTURE BEFORE SECURING THE JOINT BY INSERTING 1/4-20 MACHINE SCREW THROUGH HOUSING TOP AND FLAT STRAP. IF REQUIRED, ADJUST FLAT STRAP AND SCREW TO ENSURE PROPER STRAIGHTNESS AND ALIGNMENT.

4

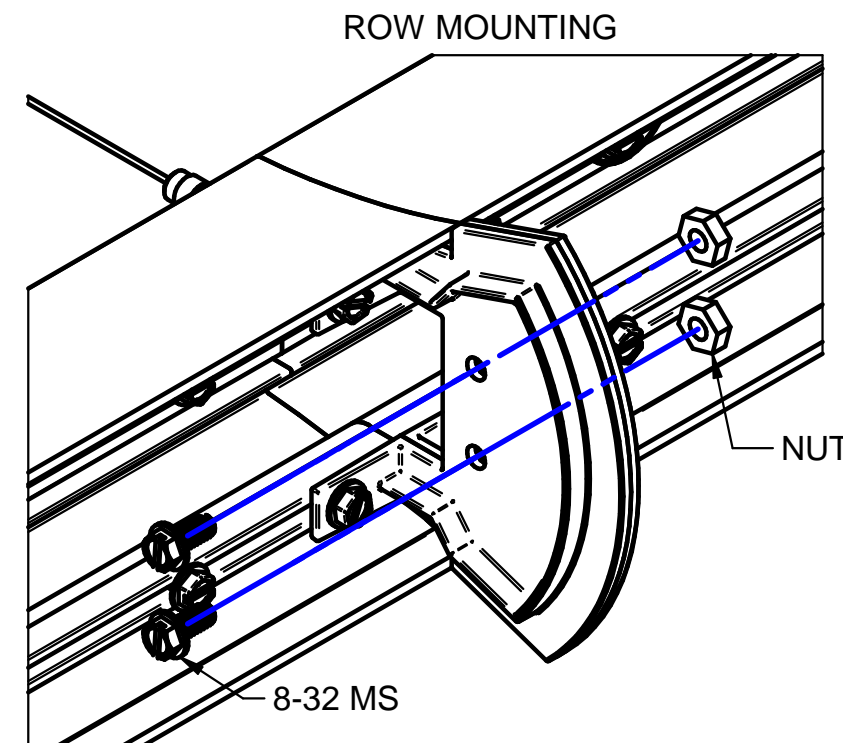

(LED REFLECTOR MODULES HIDDEN FOR CLARITY.)

SECURE JOINT USING (2) 8-32 MACHINE SCREWS AND NUTS. DO NOT TIGHTEN UNTIL FIXTURES ARE ALIGNED; LEVEL BY SLIDING CABLE GRIPPERS UP/DOWN. REPEAT STEP 3 FOR EACH ADDITIONAL FIXTURE IN ROW.

5 END CAP REMOVAL

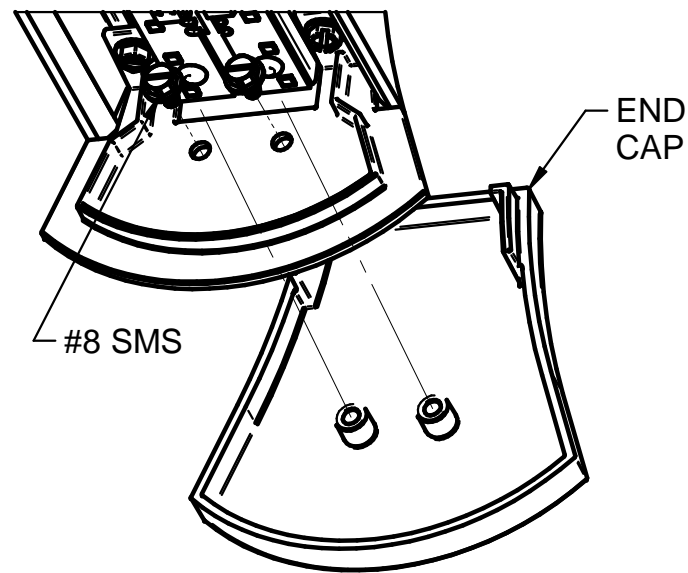

REMOVE END CAP AT BOTH ENDS OF INDIVIDUAL FIXTURE OR ROW OF FIXTURES BY REMOVING (2) #8 X 1/4" LONG SHEET METAL SCREWS.

6 LENS REMOVAL

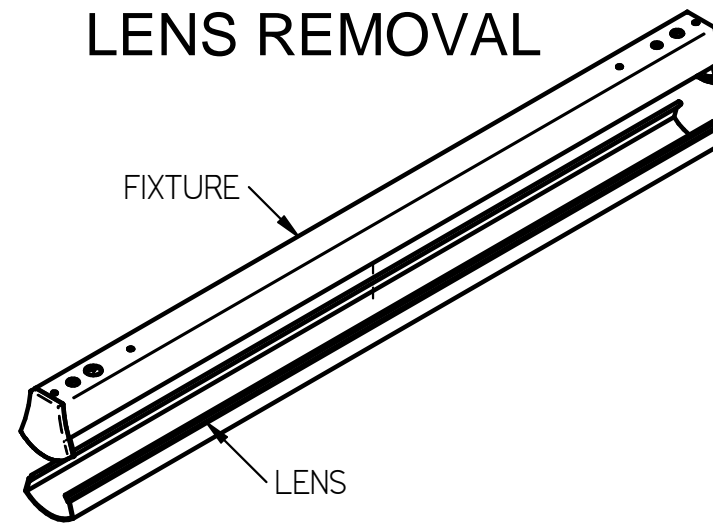

TO REMOVE LENS, START AT ONE END OF FIXTURE, GENTLY SQUEEZE SIDES OF LENS. MOVING ALONG LENGTH OF FIXTURE, CONTINUE TO GENTLY SQUEEZE SIDES OF LENS, RELEASING LENS LIP FROM HOUSING, PIVOT LENS TO ONE SIDE. GENTLY WORK LENS OUT OF END HEADERS. (TO REPLACE LENS REPEAT THE ABOVE STEPS IN REVERSE.)

7 REFLECTOR ASSEMBLY REMOVAL

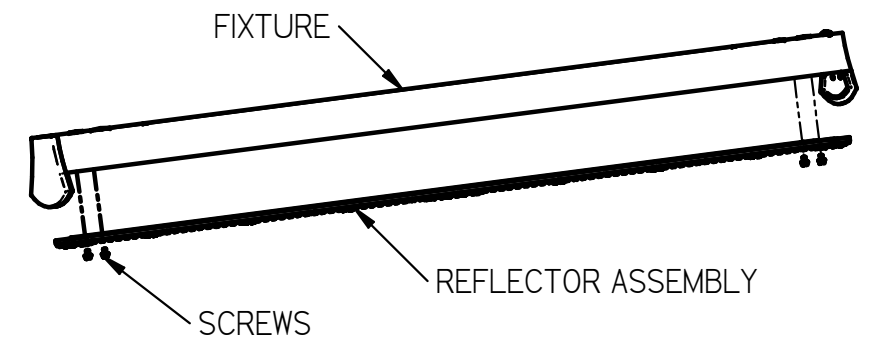

REMOVE REFLECTOR ASSEMBLY FROM FIXTURE(S) BY DETACHING (4) SCREWS. (TO REPLACE LED REFLECTOR ASSEMBLY REPEAT THE ABOVE STEPS IN REVERSE.)

8 DRIVER REMOVAL

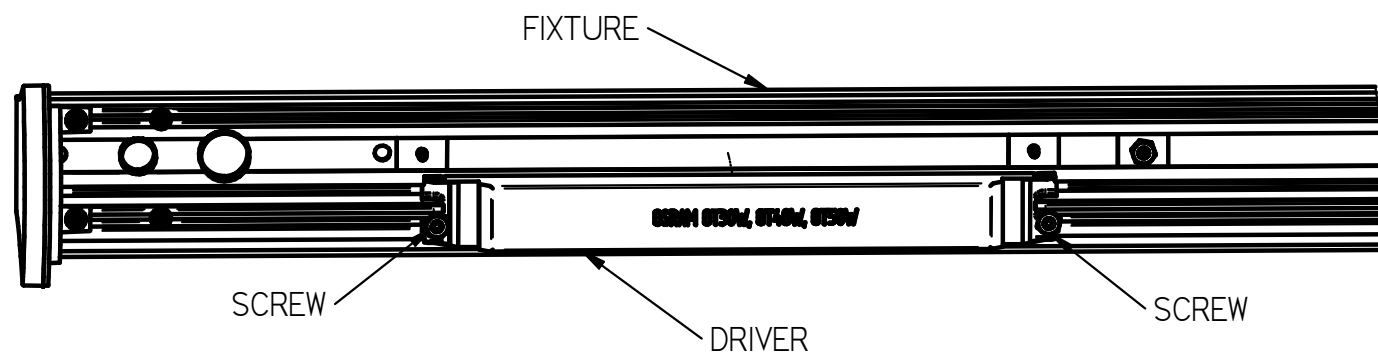

BEFORE REMOVING DRIVER SEE STEPS 6 AND 7 FOR LENS AND LED REFLECTOR REMOVAL. REMOVE THE (2) SCREWS AS SHOWN AND REMOVE DRIVER.

9 GRIPPER REMOVAL

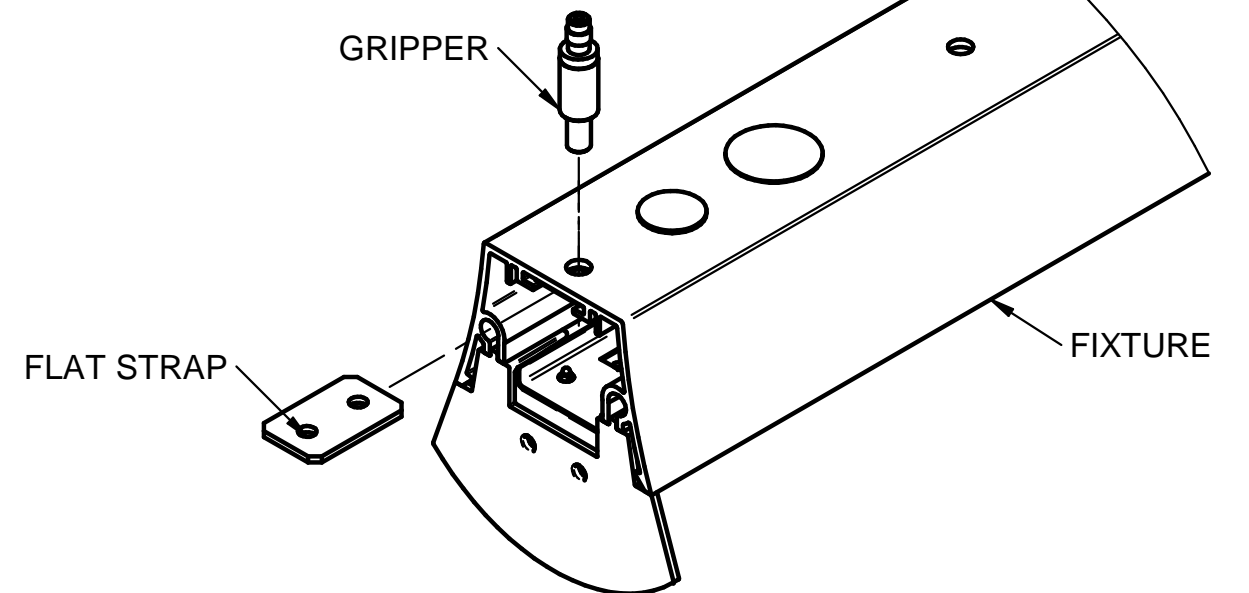

TO REMOVE GRIPPER, COMPLETELY UN-SCREW CABLE GRIPPER UNTIL BOTTOM THREADS OF CABLE GRIPPER RELEASE FROM FLAT STRAP. SLIDE OUT FLAT STRAP FROM REST AREA ON EXTRUSION TO REMOVE FLAT STRAP. REPEAT FOR ALL CABLE GRIPPERS ON FIXTURE.