

Inde-Pendants Family

32L Surface Mount Cylinder

Plaster Trim, Grid and Drywall Ceiling Types

Installation instructions for
32L-C-S-D

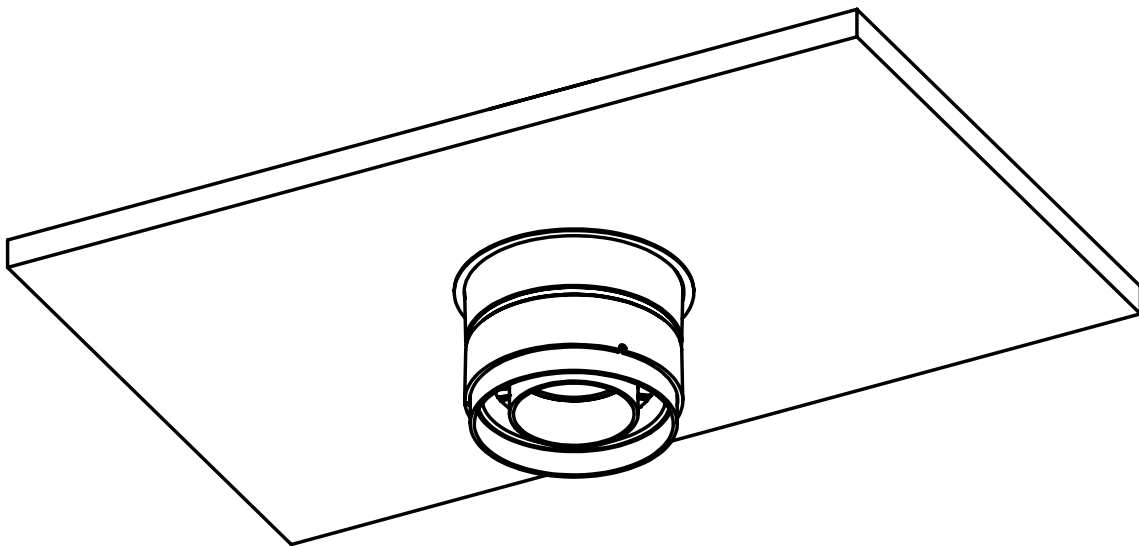

Supplied by Litecontrol

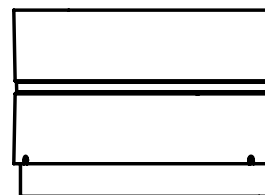

Cylinder
(fixture)
SCALE 1 : 5

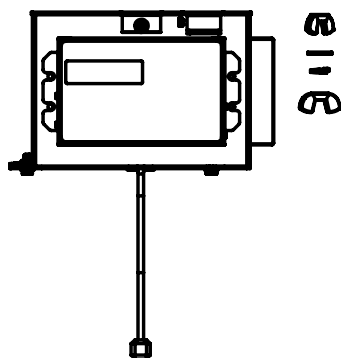

J-box/Cable Kit Assembly
with mounting hardware
SCALE 1 : 5

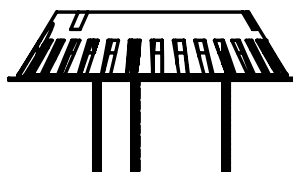

Canopy Interface
SCALE 1:5

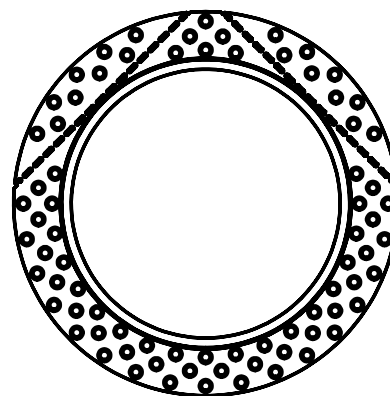

Trim Ring
(Plaster Trim Applications Only)
SCALE 1 : 5

Supplied by Contractor

- 1/4-20 Threaded rod with mounting hardware
- Ceiling tile (T-Grid)
- Romex connectors or alternative hardware for 7/8" knockouts
- Feed cord
- Wire nuts
- Joint Compound, drywall screws and paint to match ceiling (Plaster Trim applications only)

Tools Required

- Wire cutters/strippers
- Tape measure
- 9mm Socket with wrench
- Small phillips-head screwdriver
- Joint knife and paint roller (Plaster Trim applications only)

Ceiling Cut Stencil (not for use with Trim Ring)



To Use Stencil:

1. If using a square tile, draw two lines on the back of the tile from corner to corner so that they intersect at the exact center of the tile to make an "X"
2. Using a pen, screwdriver, etc. punch a small hole through the tile in the center of the "X"
3. Using a pen, screwdriver, etc. punch a small hole through the black dot in the center of the stencil
4. Flip the tile over so that the front face (that will be visible after installation) is face-up
5. Lay the stencil perfectly flat on the tile so that the hole in the stencil is perfectly centered over the hole that was punched in the tile in Step 2 and secure the stencil in place with tape
6. Using a jig-saw, cut the hole in the tile by tracing the stencil **on the black line**
7. Discard stencil after one use

Ceiling Cut Stencil (for use with Trim Ring)



PLASTER CEILINGS

To Use Stencil:

1. If using a square tile, draw two lines on the back of the tile from corner to corner so that they intersect at the exact center of the tile to make an "X"
2. Using a pen, screwdriver, etc. punch a small hole through the tile in the center of the "X"
3. Using a pen, screwdriver, etc. punch a small hole through the black dot in the center of the stencil
4. Flip the tile over so that the front face (that will be visible after installation) is face-up
5. Lay the stencil perfectly flat on the tile so that the hole in the stencil is perfectly centered over the hole that was punched in the tile in Step 2 and secure the stencil in place with tape
6. Using a jig-saw, cut the hole in the tile by tracing the stencil on the black line
7. Discard stencil after one use

1

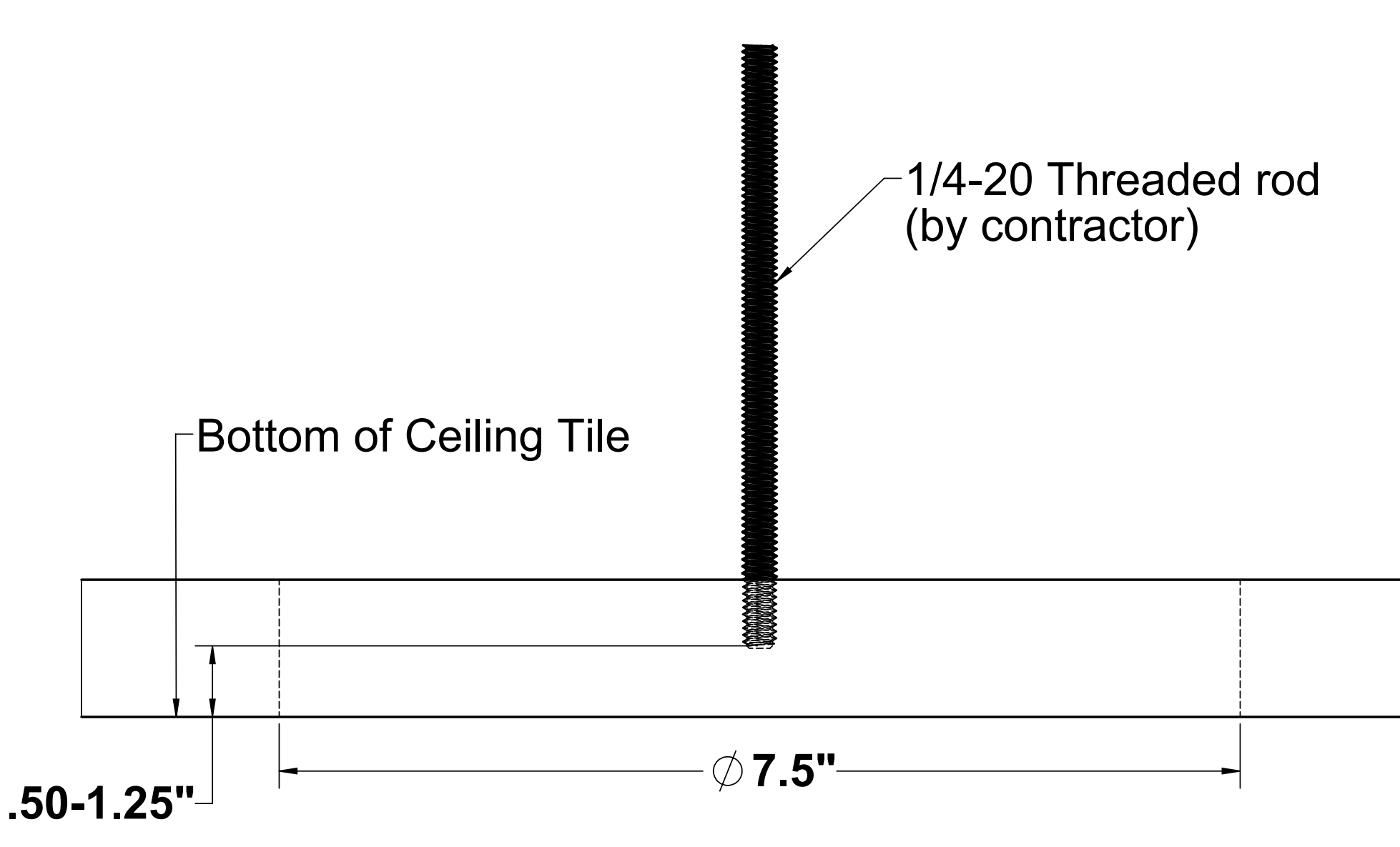
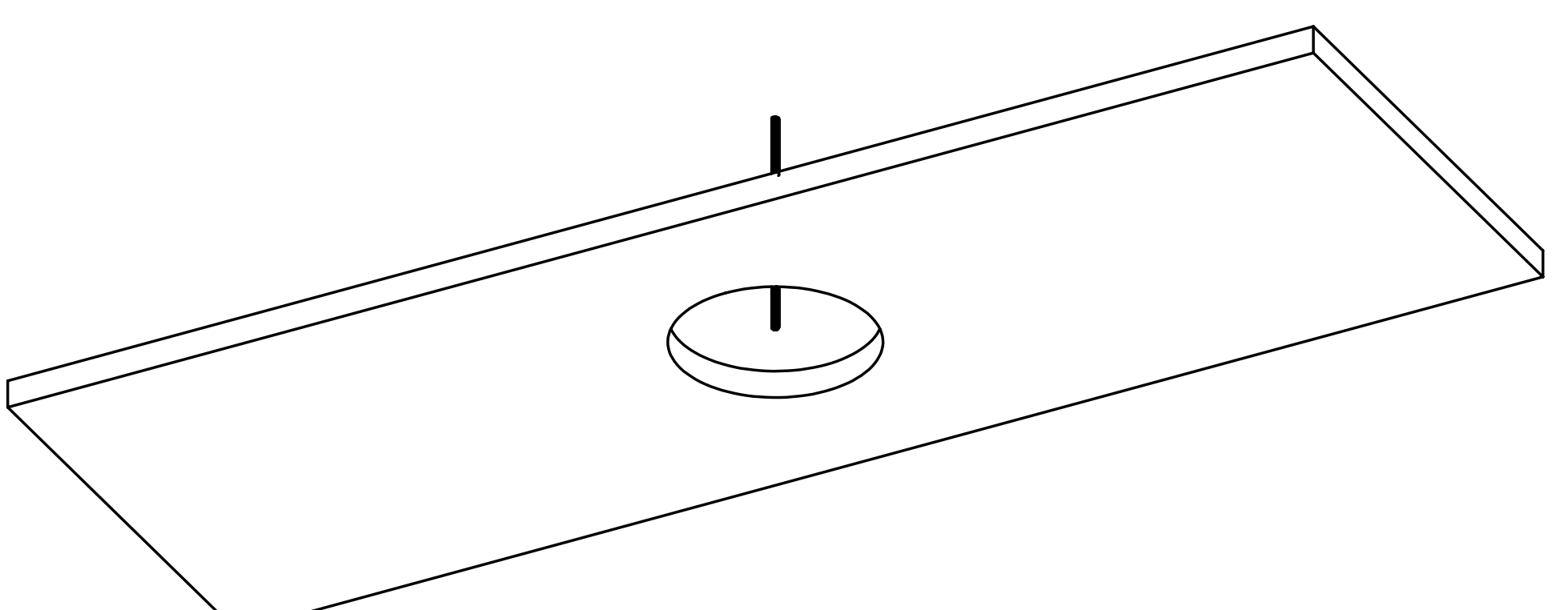

IF NOT USING TRIM RING, CONTINUE TO STEP 1 ON PAGE 6.

1. Using stencil on page 4, cut a 7.5" diameter hole in the ceiling (ceiling thickness cannot exceed 3")
2. Suspend a **1/4-20 threaded rod** per code at the support location so that it ends .5" to 1.25" above the visible ceiling face (bottom of ceiling tile), centered above the hole.

2

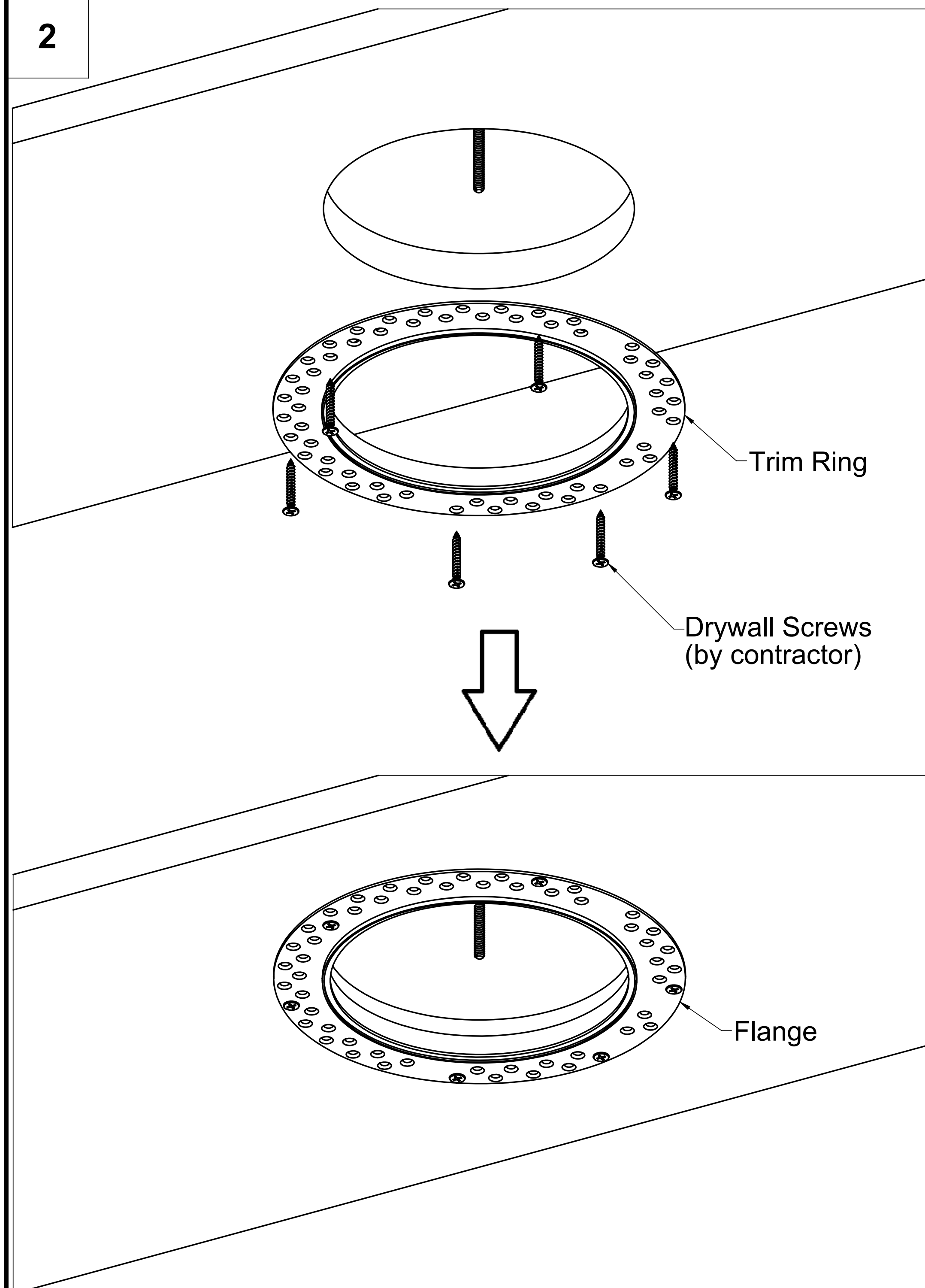

1. Install **Trim Ring** in ceiling hole as shown.
2. Secure firmly against ceiling with **drywall screws** provided by contractor (at least 6 recommended)

3

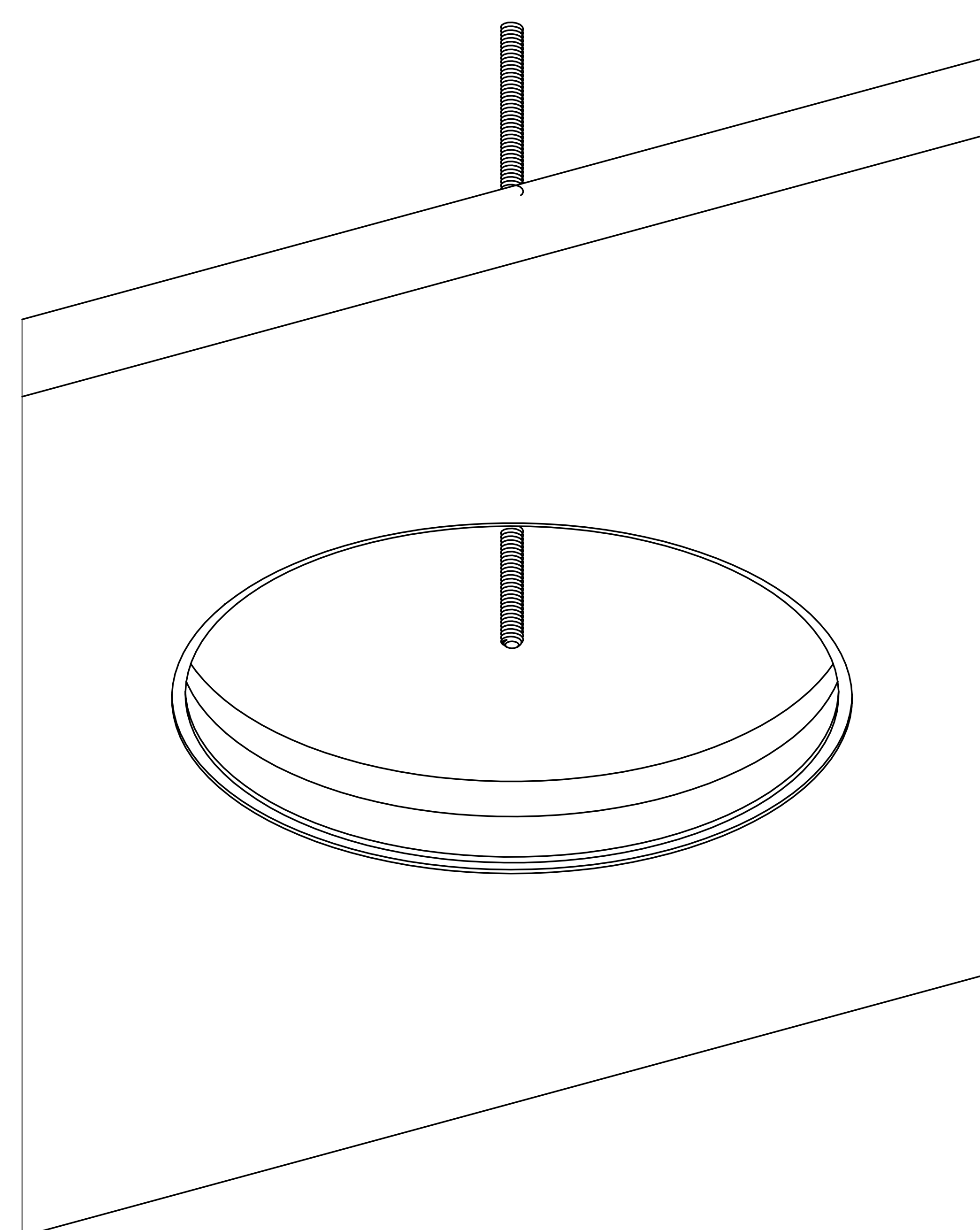

1. Plaster over the **Flange** of the **Trim Ring** and the **Drywall Screws** until they are no longer visible and the ceiling appears to be completely smooth (2-3 coats recommended).
2. Sand down any excess plaster
3. Paint over newly-plastered area of ceiling so that the plastered area blends in with the ceiling.
4. Continue to **Step 2 on page 6.**

J-box and Cylinder Installation

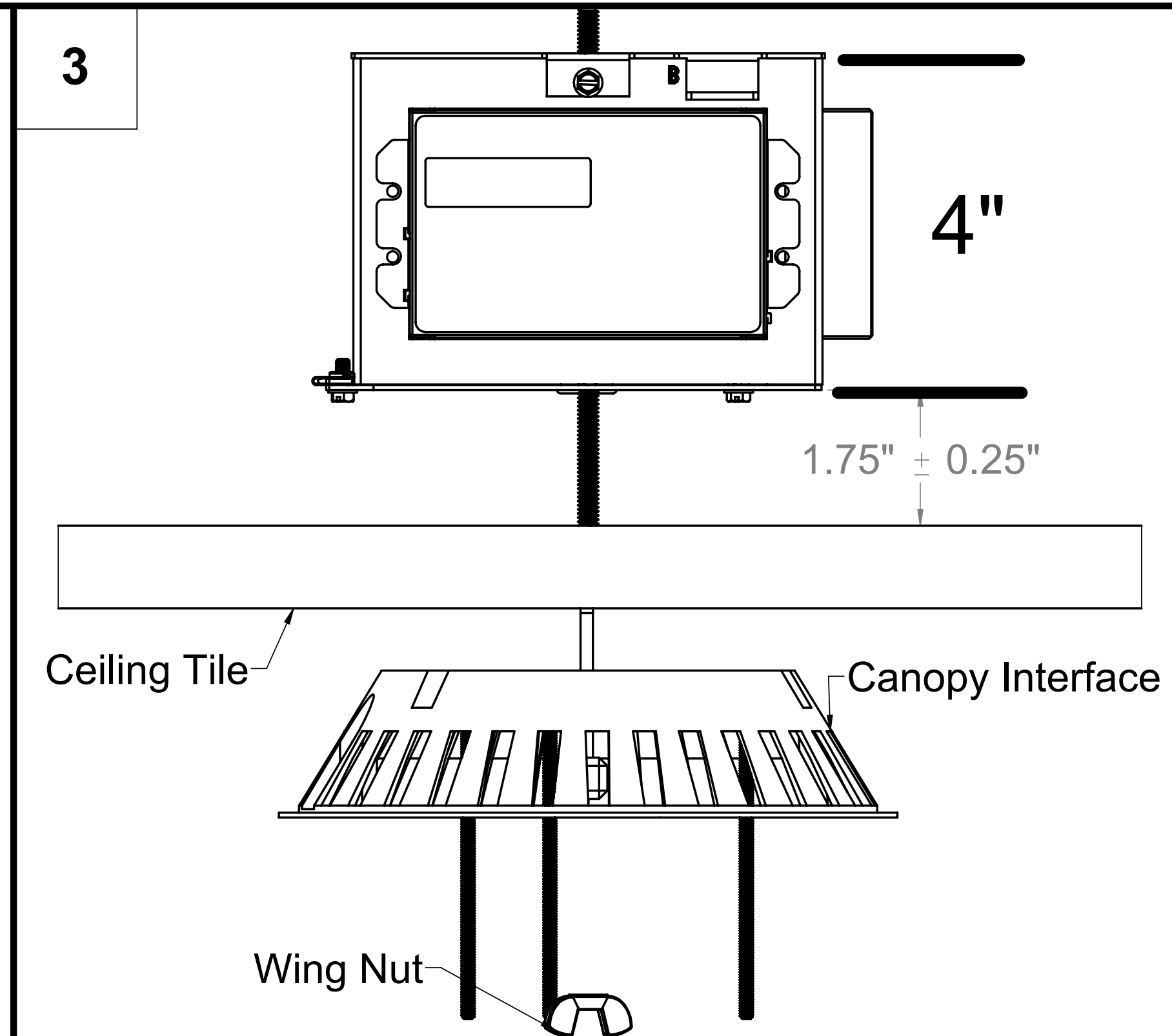
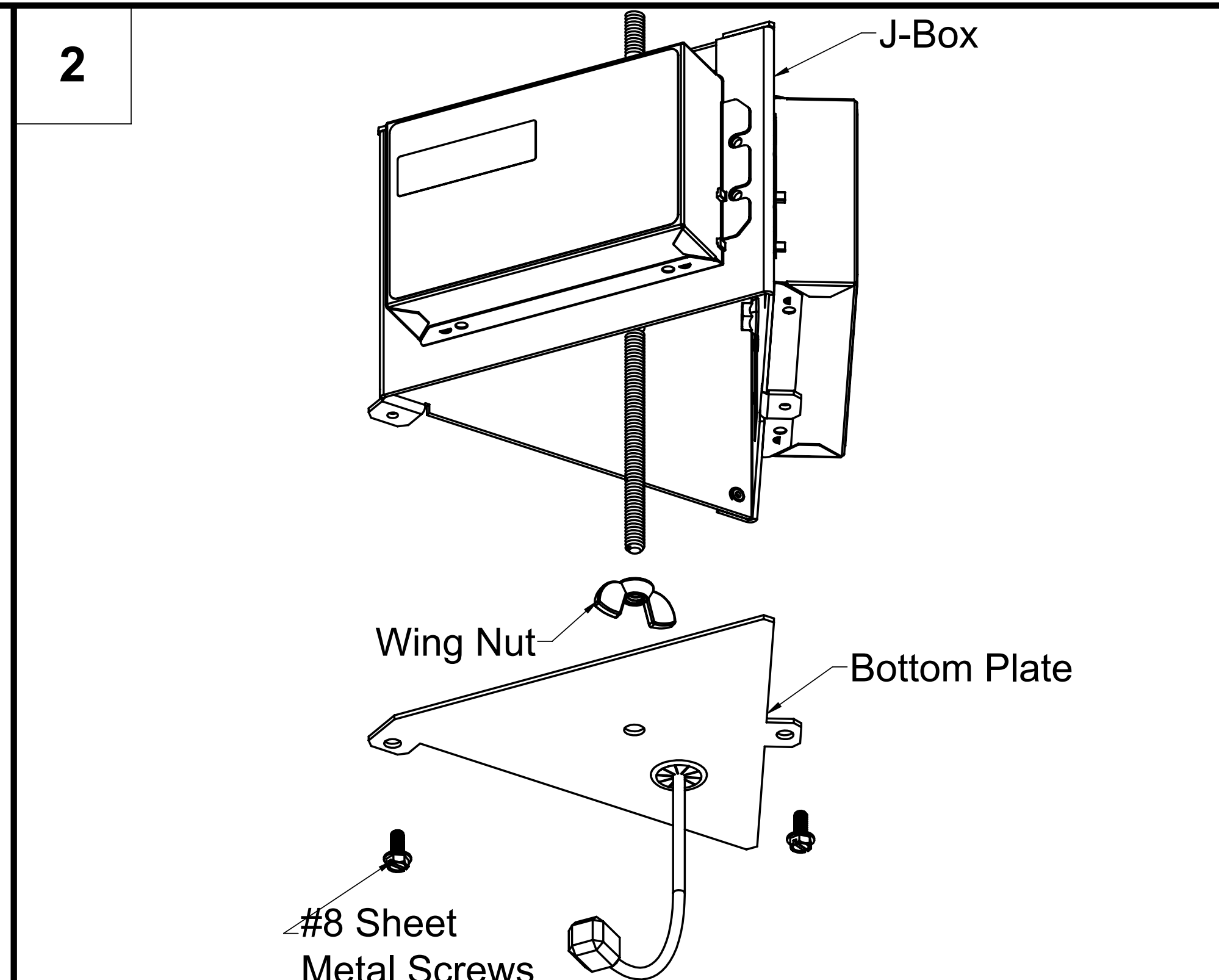
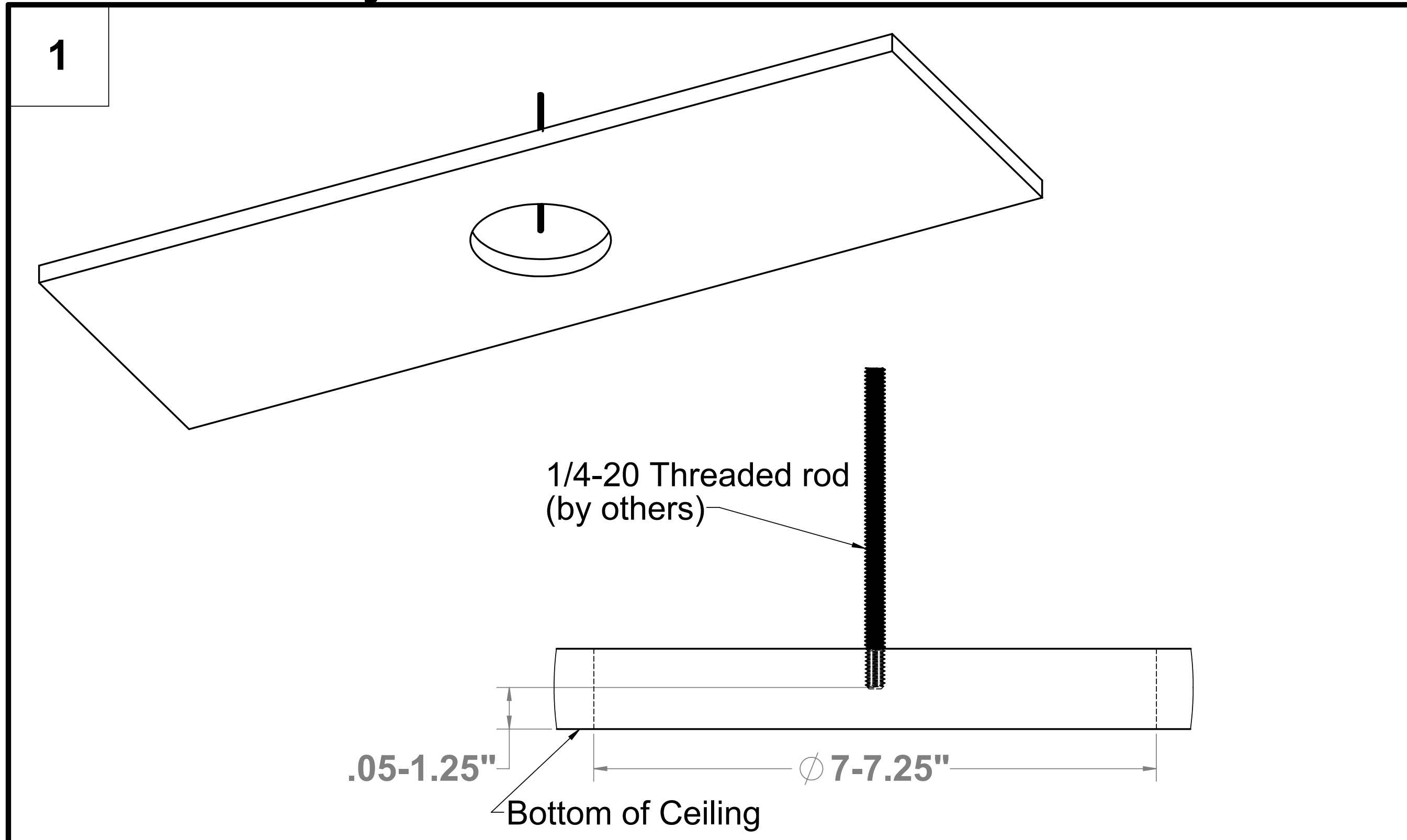

1. **Cut a 7" to 7.25" diameter hole in the ceiling tile** (ceiling thickness cannot exceed 3")
 2. Suspend a **1/4-20 threaded rod** per code at the support location so that it ends .5" to 1.25" above the visible ceiling face (bottom of ceiling tile), centered above the hole.

1. Remove the **bottom plate** of the J-box
 2. Punch out however many knockouts are needed (1-3) in the **J-box top**.
 3. Lift the **J-box** up while sliding the threaded rod through the center hole in the top of the J-box so that there is about 1.75" distance between the bottom of the J-box and the top of the ceiling tile
 4. Secure the J-box in place with a **1/4-20 wing nut**
 5. Make all wiring connections. **Power supply circuit enters the J-box through the 7/8" knockouts on the J-box top.**
 6. Re-install the bottom plate using the two **#8 screws**.

1. Bring the 4-conductor wire coming out of the J-box through one of the openings in the top of the **canopy interface**.
 2. Lift the canopy interface up and slide the threaded rod through the center hole in the top
 3. Secure with **wing nut** until the flange of the canopy interface begins to press against the ceiling tile.

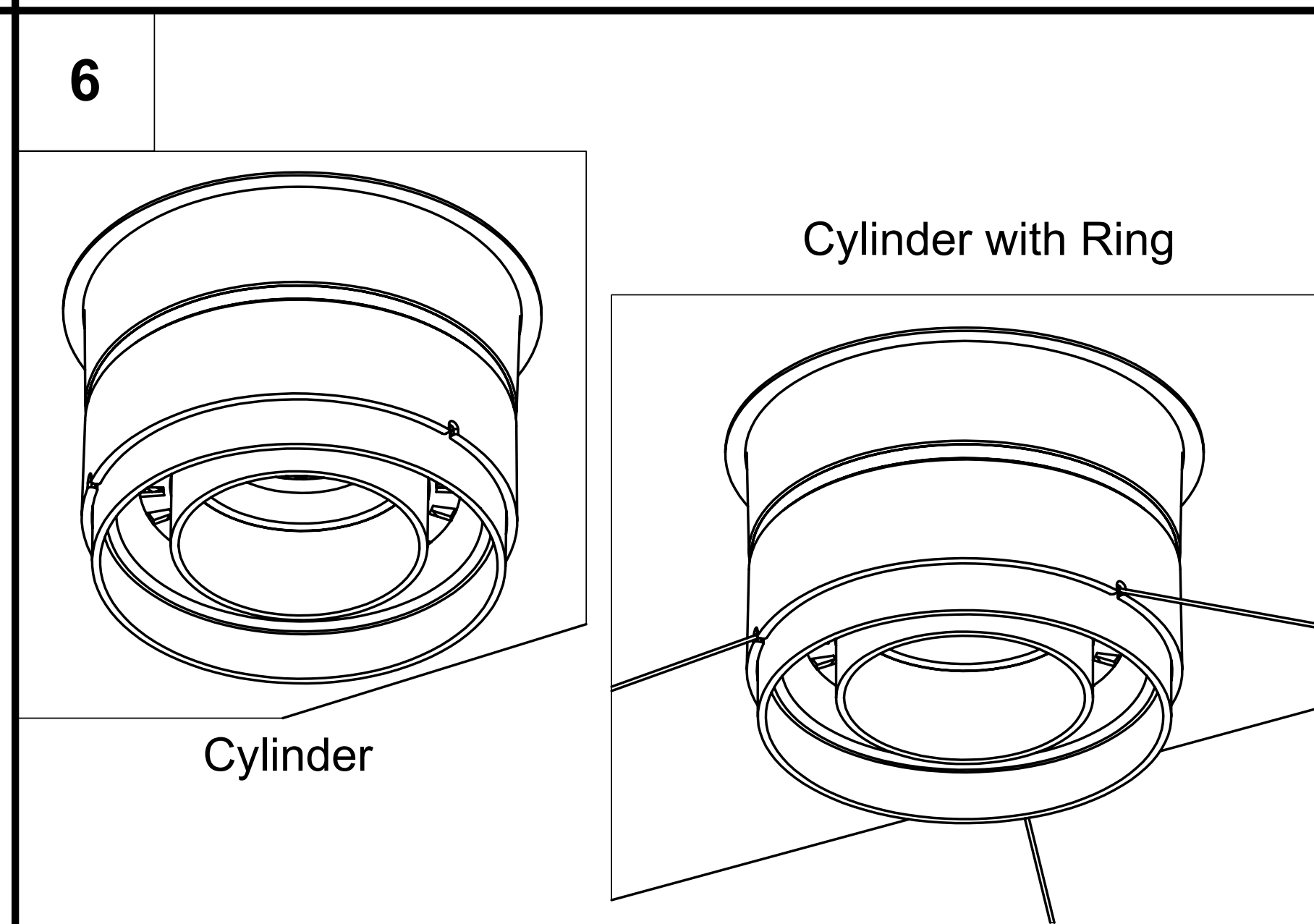
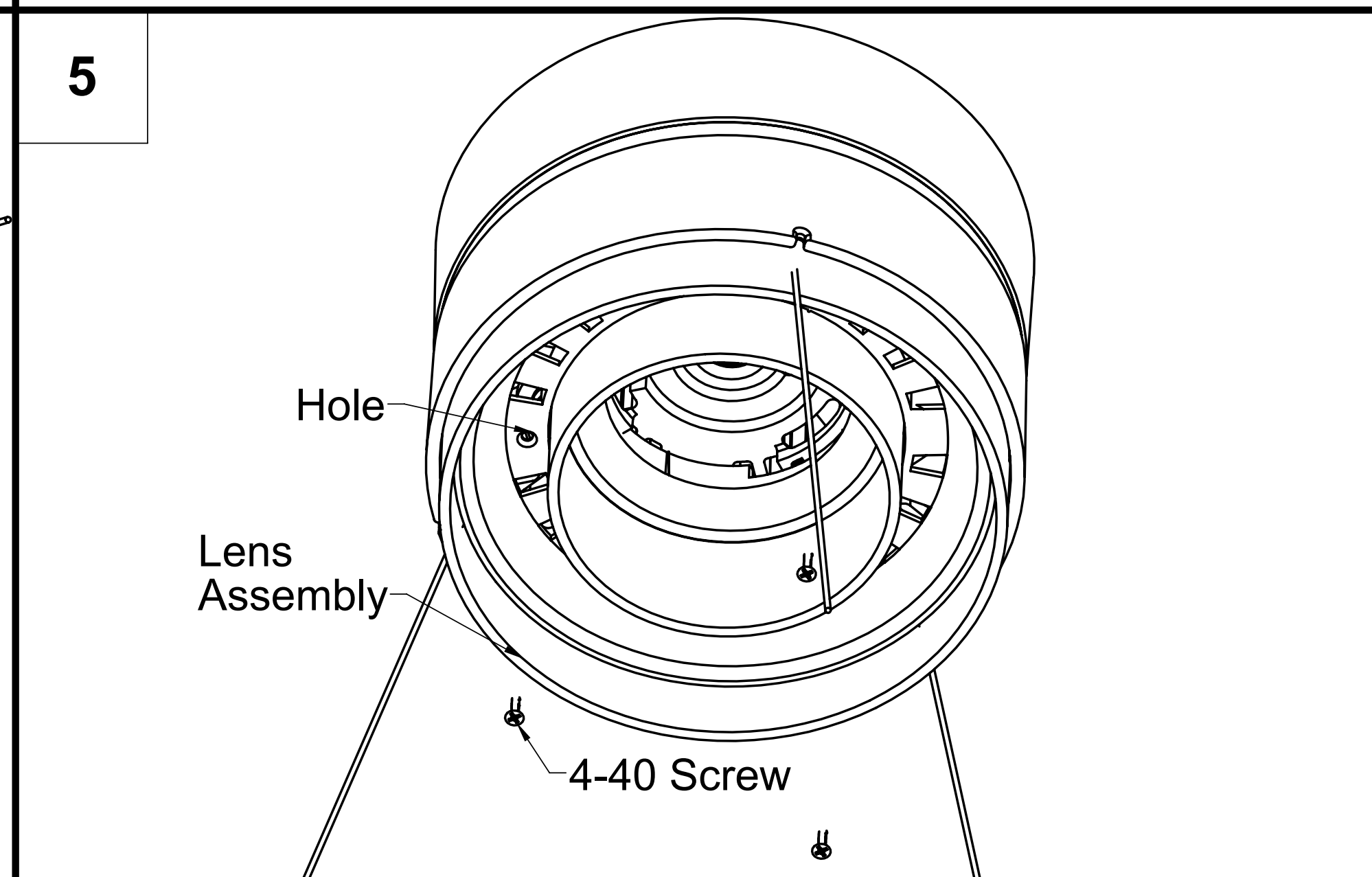
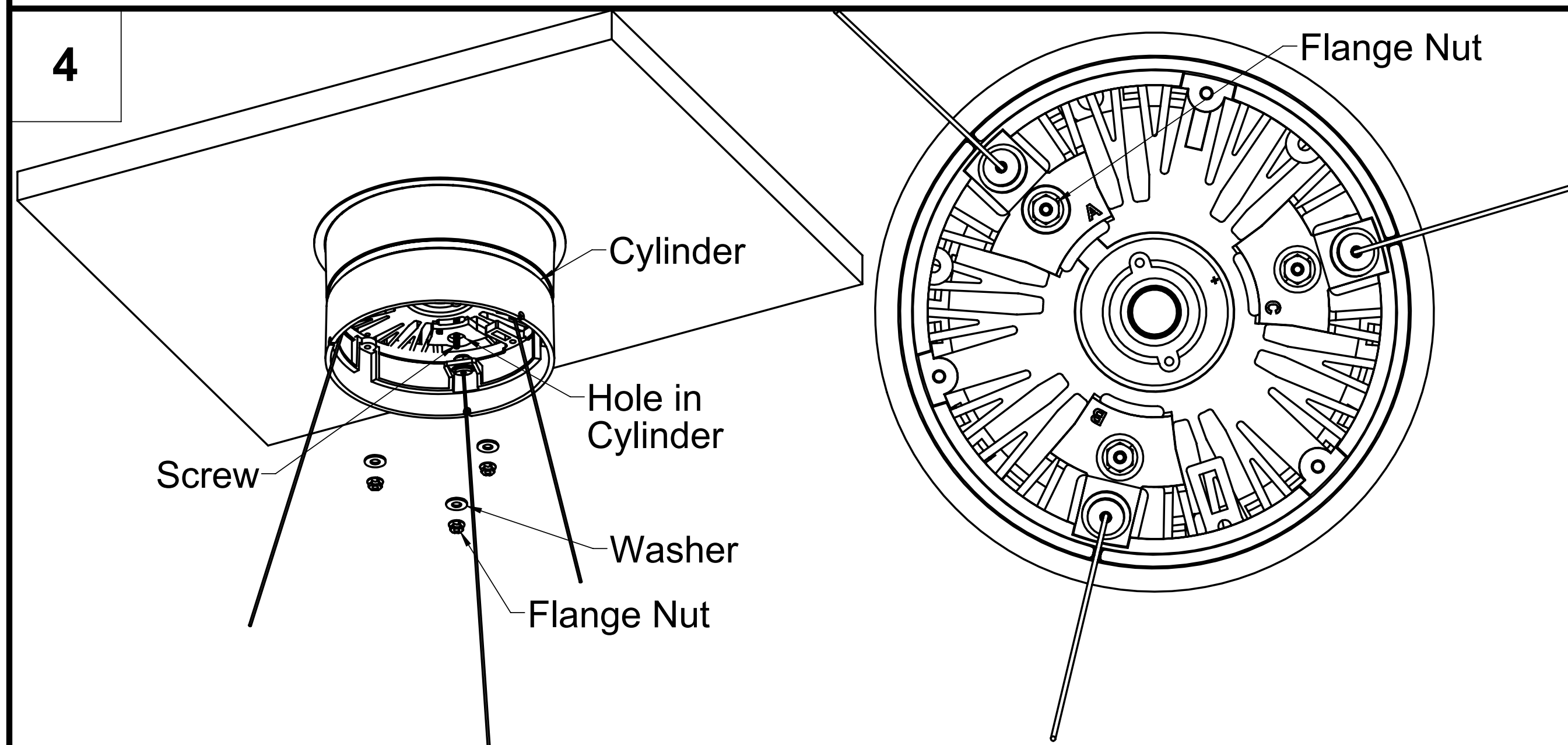

1. Make the wiring connections between the 4-conductor wire and the **Cylinder** before installing it.
 2. To install the Cylinder, align the **screws** in the canopy interface with the **holes** in the Cylinder as shown, and bring the Cylinder up against the Canopy Interface.

Note: Make sure that all wires are tucked inside the top of the Cylinder before securing it to the ceiling with the washers and 8-32 flange nuts

510656-01

1. Install the **Lens Assembly** in the Cylinder using the three **4-40 black oxide screws** as shown.

Note: For fixtures that will also have a ring attached, make sure that the cables coming from the bottom of the Cylinder go smoothly through the slots in the Cylinder without being pinched. These slots can also be useful in aligning the Lens Assembly with the Cylinder so that the holes line up.

For Cylinder only fixture (left), the installation is now complete. Reverse instructions to uninstall fixture and J-box.

For Cylinder with Ring fixture (right), see Ring installation sheets to complete installation.

WIRING DIAGRAM

APPLICABLE FIXTURE TYPES:

- 32L-C-S-D

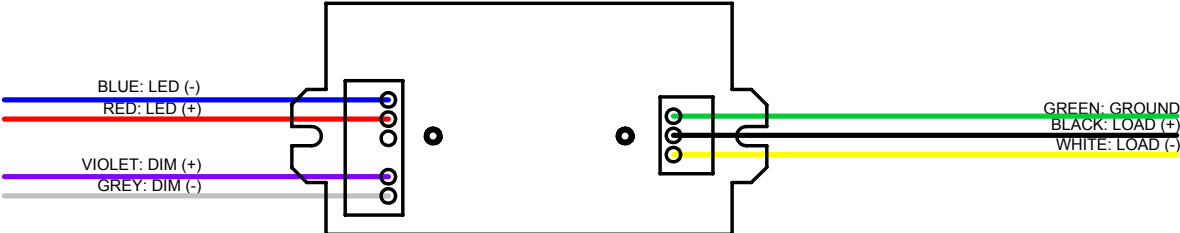

Cylinder Label Positioning

If fixture is damaged or additional assistance is needed, call the number on the label to speak with a Litecontrol representative

CONTACT LITECONTROL FOR REPLACEMENT PARTS 781-294-0100	MODEL: 32L DATE: ___/___/___ CCT: _____	LMA  C US 159392
---	--	--

