

2L-DW CROSS SECTION

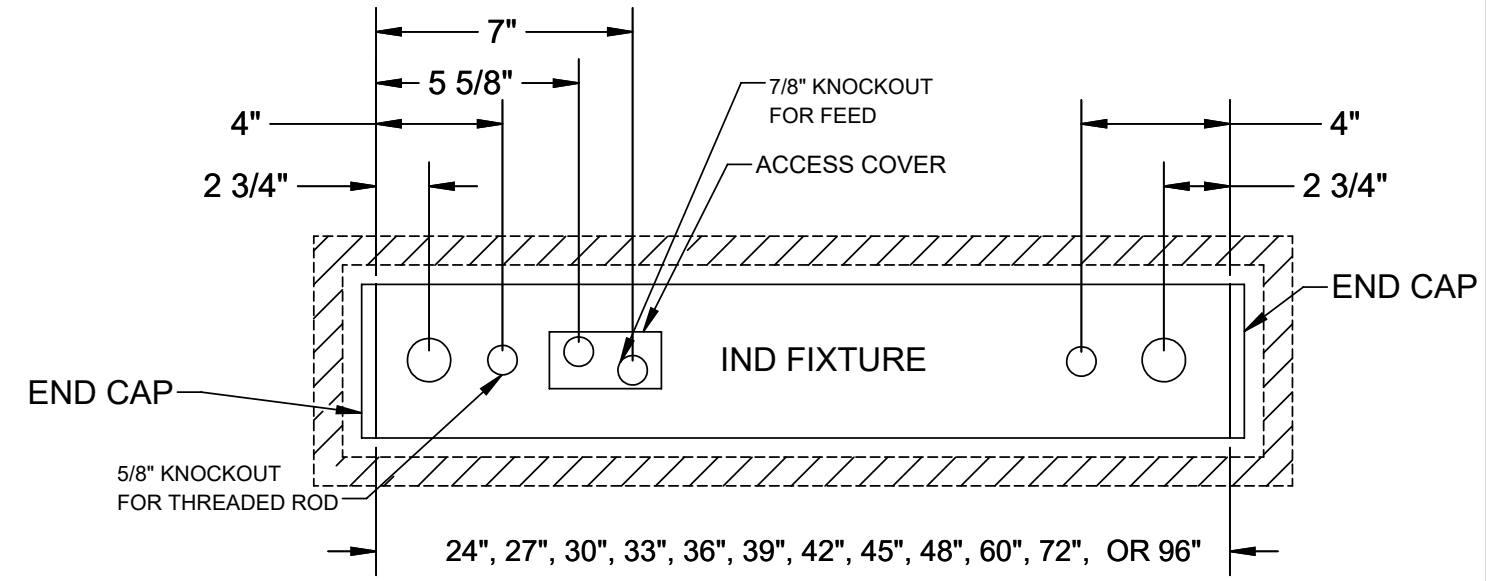

TOP VIEW - INDIVIDUALLY MOUNTED RECESSED FIXTURE

TOP VIEW - ROW MOUNTED RECESSED FIXTURE

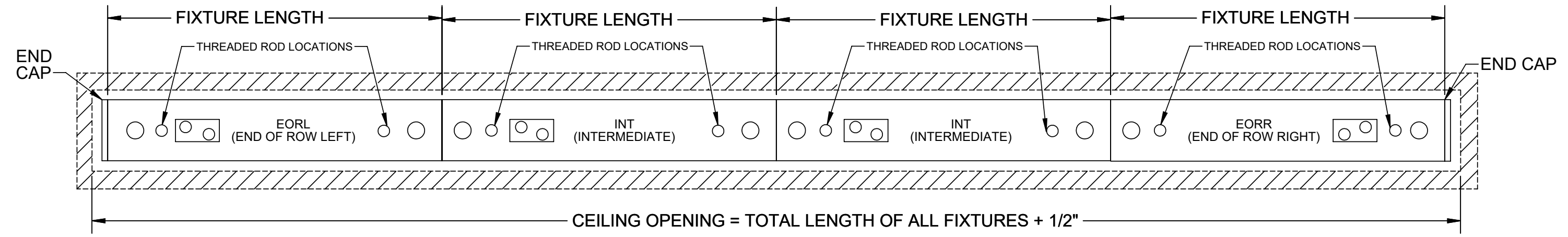

- GENERAL NOTES: (READ SHEETS COMPLETELY BEFORE STARTING)**
1. LEAVE PROTECTIVE WRAPPING ON FIXTURE UNTIL START OF INSTALLATION.
 2. REFER TO SUPPLEMENTAL WIRING INSTRUCTION SHEET 510401 WHEN MAKING WIRING CONNECTIONS.
 3. FIXTURES ARE MOUNTED, SUPPORTED BY (2) 1/4-20 THREADED RODS SUPPLIED BY INSTALLER.
 4. APPROXIMATE WEIGHT OF FIXTURE IS 3.50 LBS PER FOOT OF LENGTH.

TOOLS REQUIRED	SUPPLIED BY INSTALLER
SCREWDRIVER OR 1/4" HEX DRIVER/SOCKET 7/16" HEX DRIVER/SOCKET	1/4-20 THREADED ROD

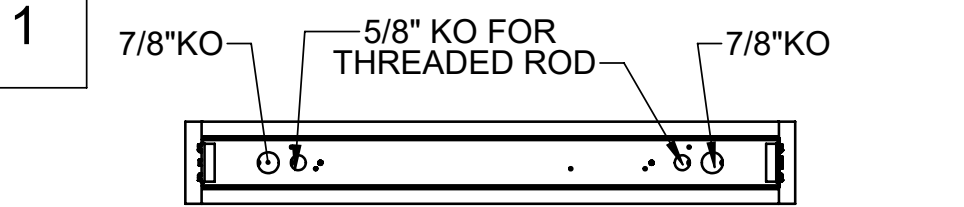

2' IND SHOWN. NO ACCESS PLATE ON 2' FIXTURES. USE 7/8" KO FOR FEED.

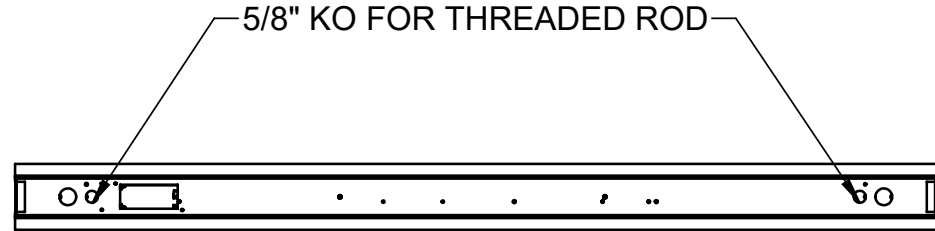

REMOVE BOTH 5/8" KO'S AT ENDS OF FIRST FIXTURE IN ROW (OR INDIVIDUAL FIXTURE)

LOCATE AND INSTALL (2) 1/4-20 THREADED RODS AT CEILING LOCATIONS SHOWN IN PLAN VIEW ON PAGE 1.

NOTE: END THREADED RODS 1 3/4" ABOVE FINISHED CEILING AS SHOWN IN CROSS SECTION ON PAGE 1.

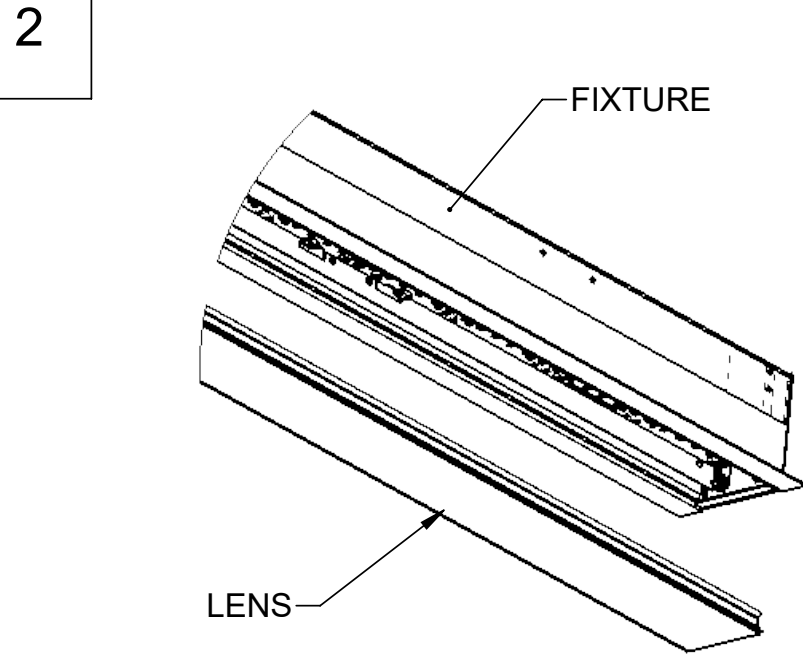

TO REMOVE, PULL LENS GAP COVER DOWN AND INSERT SCREWDRIVER OR FLATHEAD PRY TOOL INTO THE END OF THE HOUSING AND PULL DOWN.

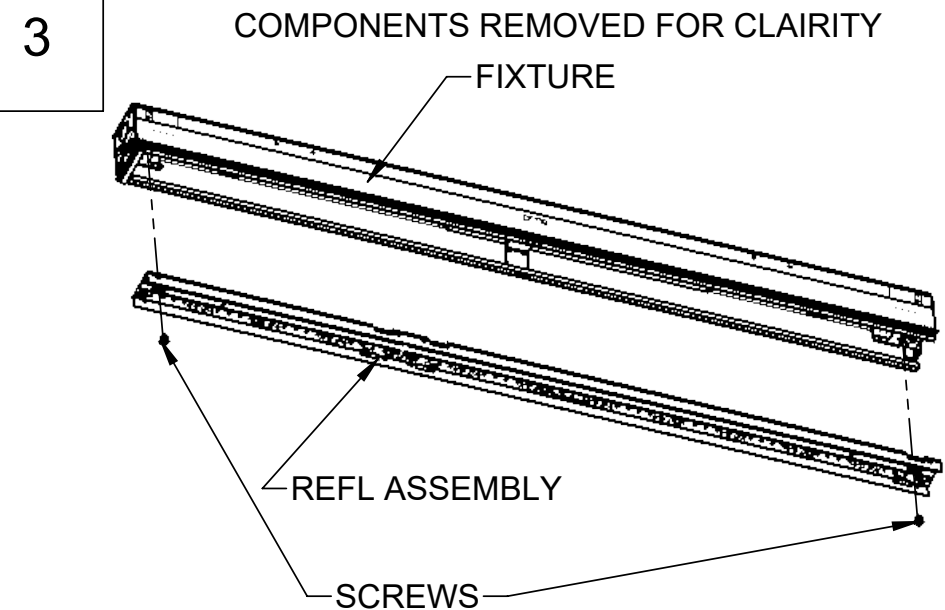
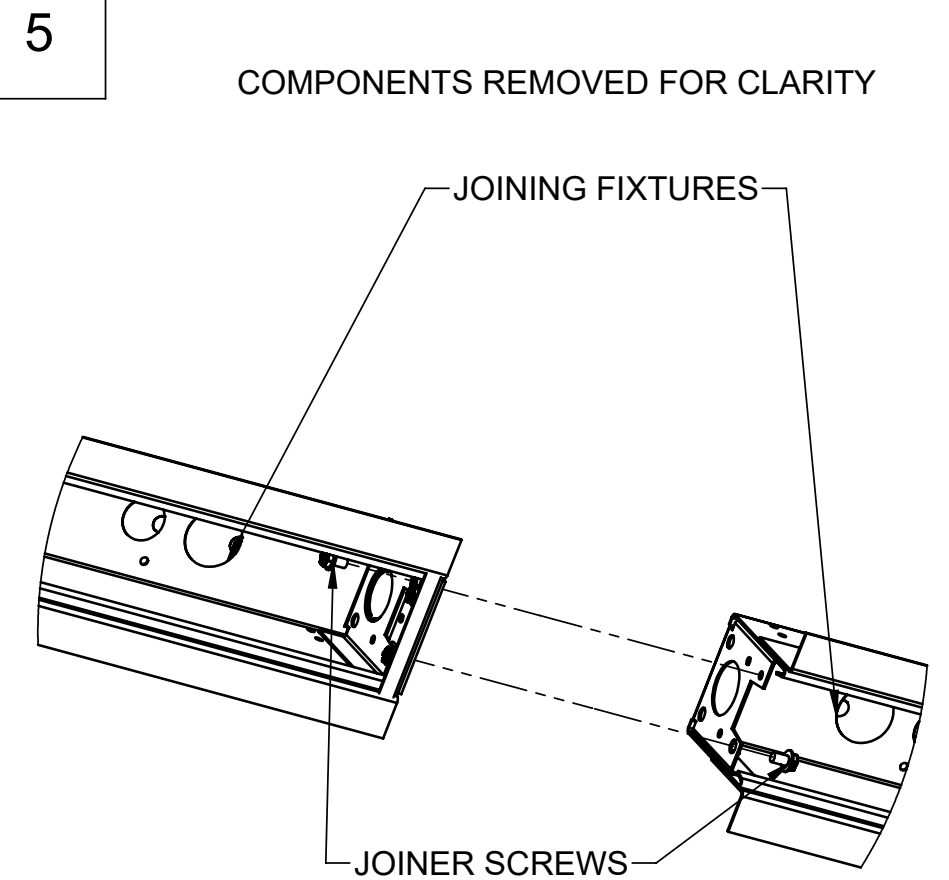

DETACH LED REFLECTOR ASSEMBLY BY REMOVING (2) 8-32 SCREWS

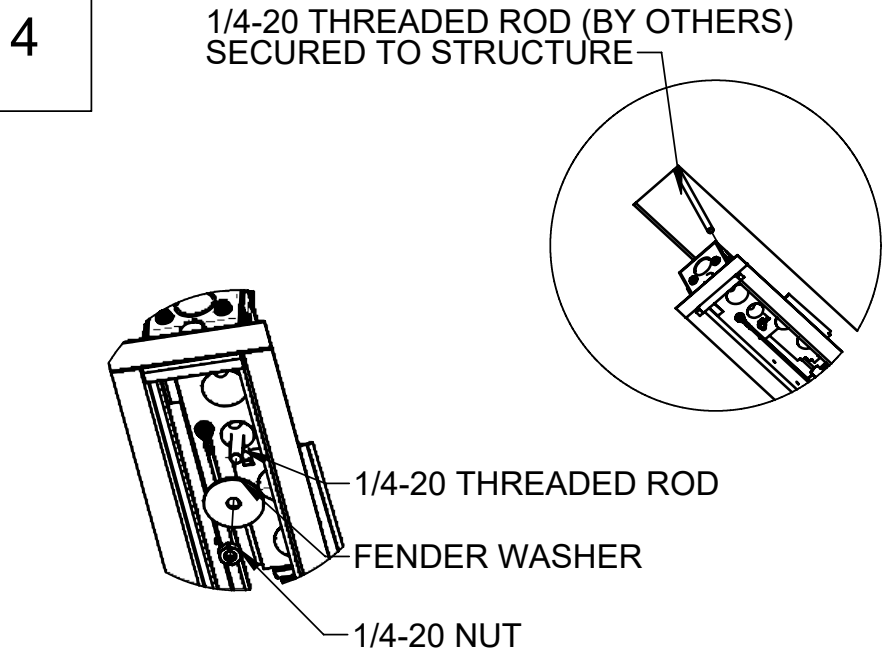

LIFT FIXTURE UP NEAR CEILING OPENING AND BRING ELECTRICAL FEED INTO FIXTURE WIREWAY THROUGH ACCESS PLATE. RAISE FIXTURE UP FLUSH TO CEILING OPENING AND SECURE TO THREADED RODS WITH FENDER WASHERS AND NUTS AS SHOWN ABOVE. (FOUND IN POLYBAG)

MAKE ALL ELECTRICAL CONNECTIONS IN FIXTURE WIREWAY AND RE-INSTALL ACCESS COVER PLATE.

REPEAT STEPS 1-4. LOOSELY BOLT ADJOINING FIXTURE TO THE PREVIOUS FIXTURE THROUGH BOTH END HEADERS AS SHOWN ABOVE. ALIGN SEAMS AT ROW JOINTS BEFORE TIGHTENING SCREWS.

NOTE: FOLLOW ORIENTATION OF SCREW HEADS SHOWN.

BRANCH CIRCUIT WIRES CAN BE ROUTED THROUGH 7/8" HOLE IN END HEADERS.

6

LENS REMOVAL

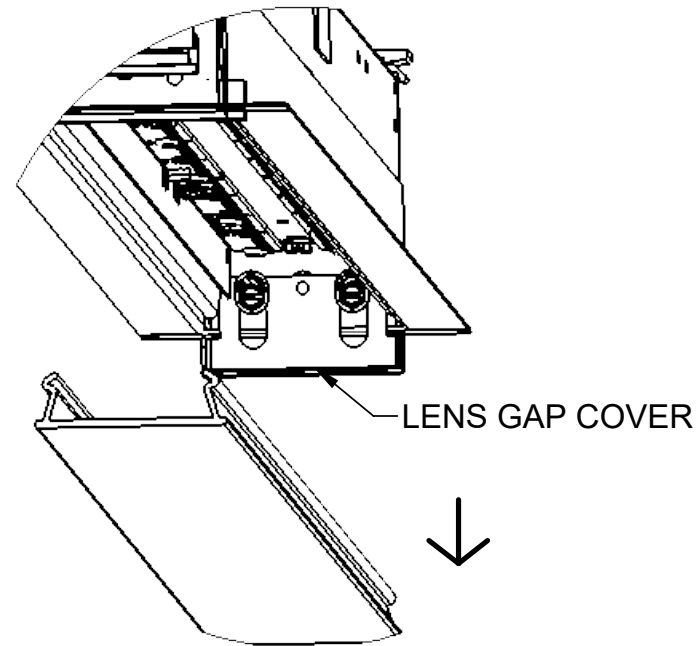

TO REMOVE, PULL LENS GAP COVER DOWN AND INSERT SCREWDRIVER OR FLAT HEAD PRY TOOL INTO THE END OF THE HOUSING AND PULL DOWN.

7

ACCESS PLATE REMOVAL

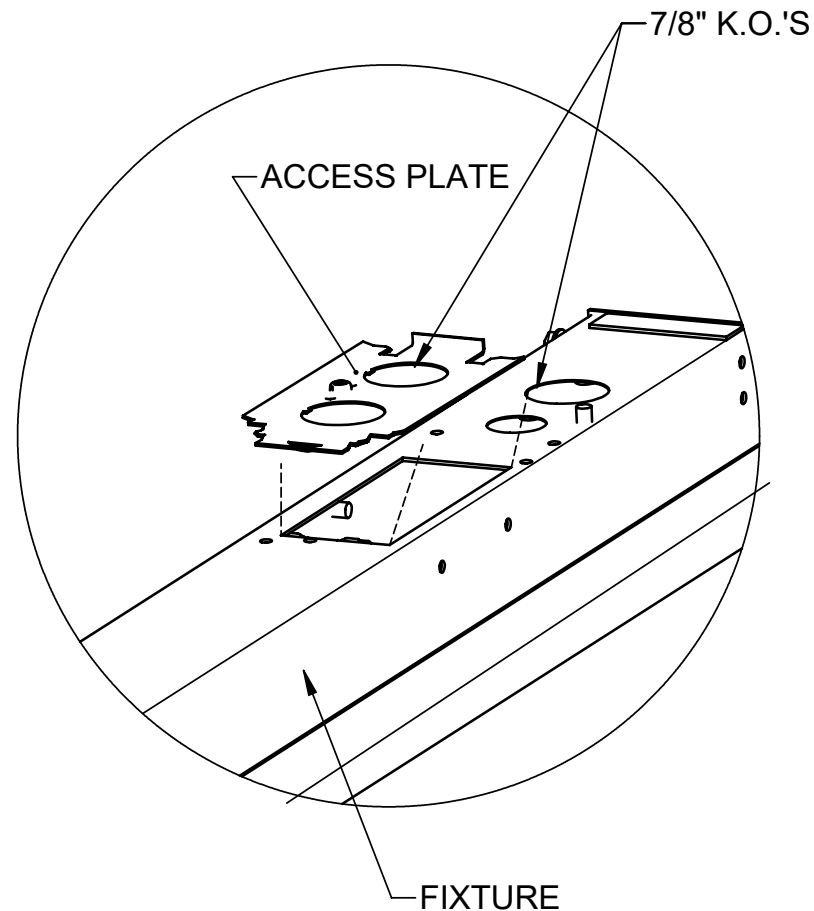

REMOVE ACCESS COVER FROM FIXTURE HOUSING BY SLIDING THE COVER AND SHIFTING IT OUT. REMOVE 7/8" KNOCK-OUT AT DESIRED FEED LOCATION.

8

END CAP REMOVAL

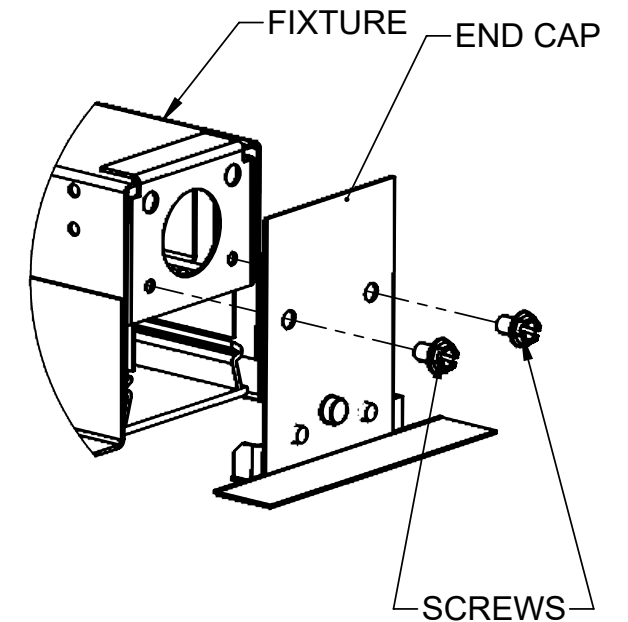

COMPONENTS REMOVED FOR CLARITY

REMOVE THE END CAP ASSEMBLIES BY REMOVING (2) #8 SCREWS AS SHOWN. FOR INDIVIDUAL FIXTURE, DO SO AT BOTH ENDS. FOR ROW, DO SO AT NEAR END OF 1ST FIXTURE AND FAR END OF LAST FIXTURE.

NOTE: SKIP THIS STEP FOR ALL INTERMEDIATE FIXTURES.

9

REFL ASSEMBLY REMOVAL

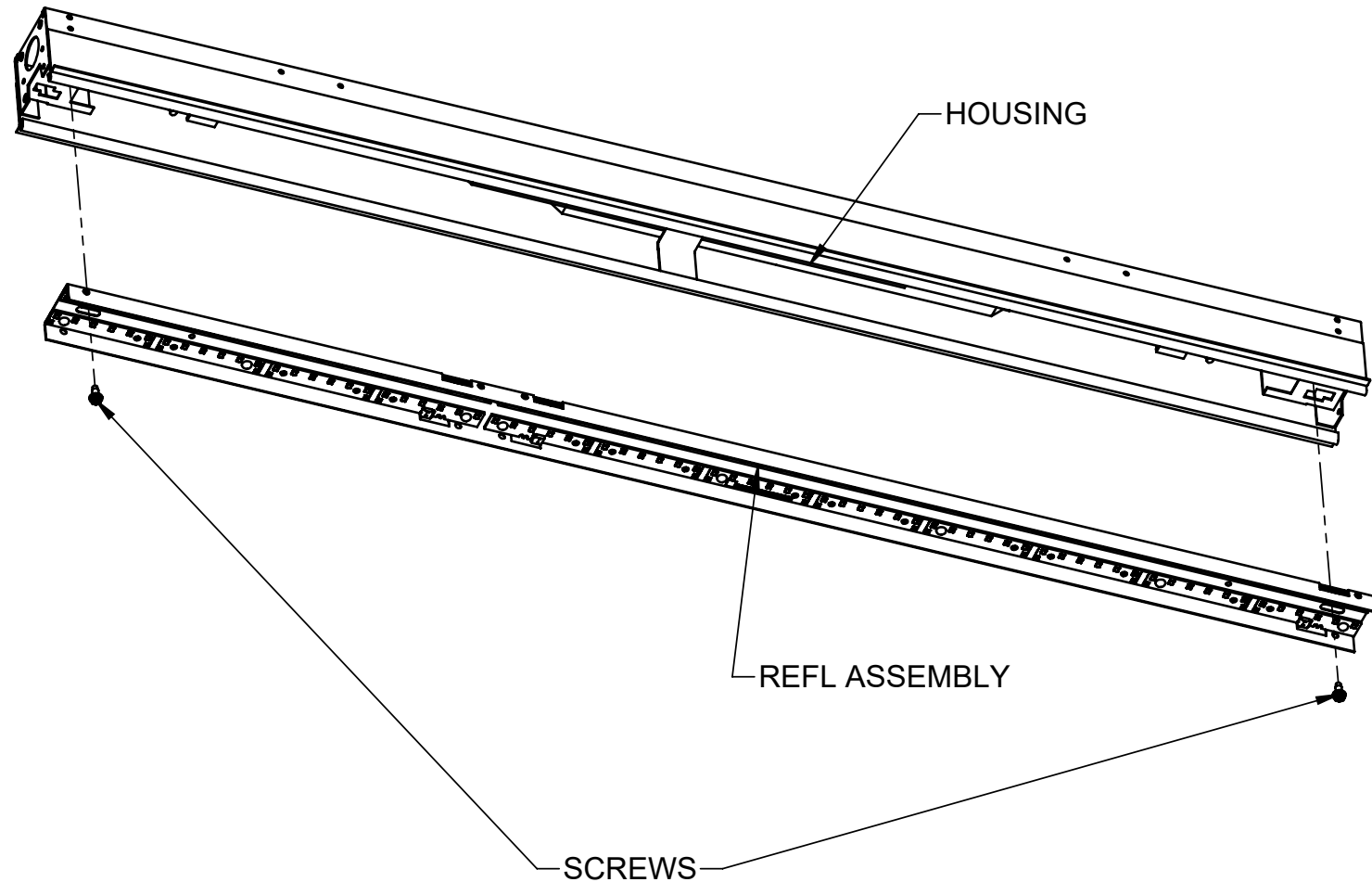

BEFORE REMOVING LED REFLECTOR ASSEMBLY SEE STEP 6 FOR LENS REMOVAL.
 TO REMOVE LED REFLECTOR ASSEMBLY:
 REMOVE THE (2) #8 SHEET METALS SCREWS AS SHOWN.
 DISCONNECT WIRE NUTS THAT CONNECT LED WIRES TO DRIVER.
 DISCONNECT SAFETY TETHERS CONNECTED TO THE LED REFLECTOR ASSEMBLY
 TO FULLY REMOVE THE LED REFLECTOR ASSEMBLY FROM HOUSING.
 (TO REPLACE LED REFLECTOR ASSEMBLY REPEAT THE ABOVE STEPS IN REVERSE)

10

DRIVER REMOVAL

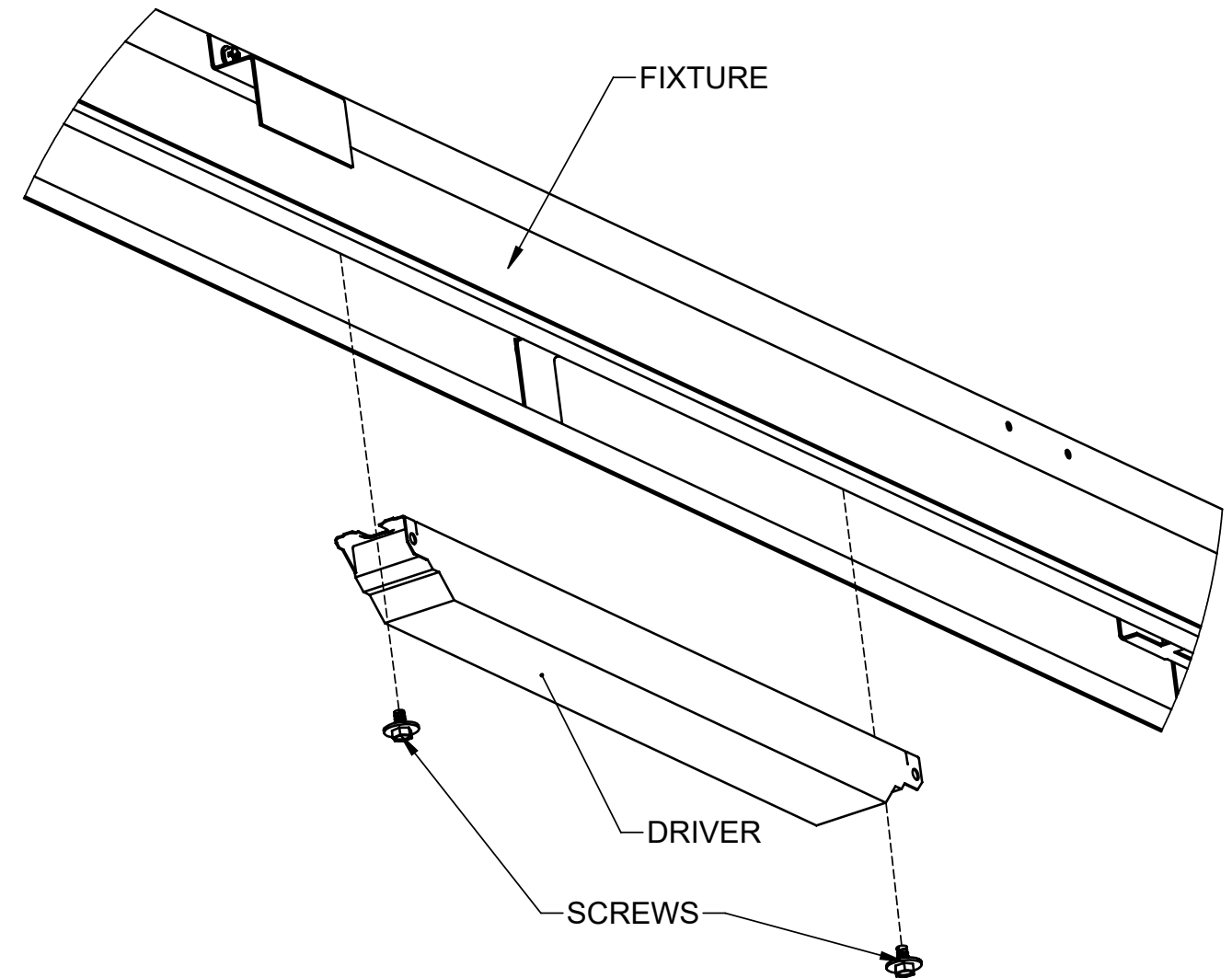

BEFORE REMOVING DRIVER SEE STEPS 6 AND 9 FOR LENS AND LED REFLECTOR
 ASSEMBLY REMOVAL. REMOVE THE (2) SCREWS AS SHOWN AND REMOVE
 DRIVER.
 (TO REPLACE LED REFLECTOR ASSEMBLY REPEAT THE ABOVE STEPS IN
 REVERSE)