

PLAN VIEW - SURFACE MOUNTED CORNER

GENERAL NOTES: (READ SHEETS COMPLETELY BEFORE STARTING)

- 1. USE THIS INSTRUCTION SHEET IN CONJUNCTION WITH INSTRUCTION SHEET 510679.**
2. LEAVE PROTECTIVE WRAPPING MATERIAL ON FIXTURE(S) UNTIL START OF INSTALLATION TO PROTECT FINISH FROM DAMAGE.
3. FIXTURES ARE PROVIDED WITH FACTORY-INSTALLED BRANCH CIRCUIT WIRING. REFER TO SUPPLEMENTAL INSTRUCTION SHEET WHEN MAKING CONNECTIONS.

TOOLS REQUIRED

- SCREWDRIVER/DRILL

SUPPLIED BY INSTALLER

1

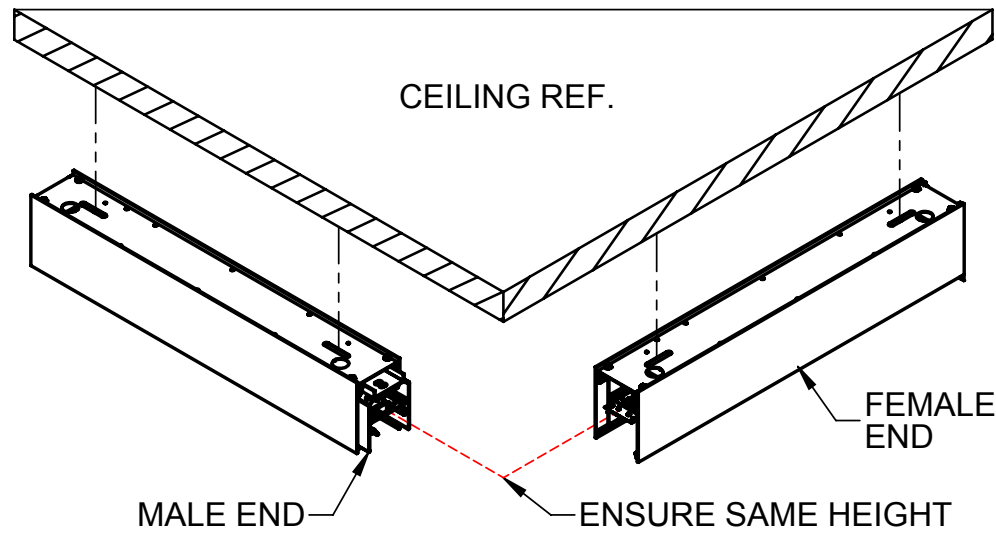

LOCATE THE LINEAR FIXTURES ADJACENT TO THE CORNER. ENSURE THAT ONE MALE END AND ONE FEMALE END ARE ORIENTED TOWARDS THE CORNER. MOUNT ONE OF THE LINEAR FIXTURES PER INSTRUCTION SHEET 510636S AND THE DIMENSIONS SHOWN ON PAGE 1.

2

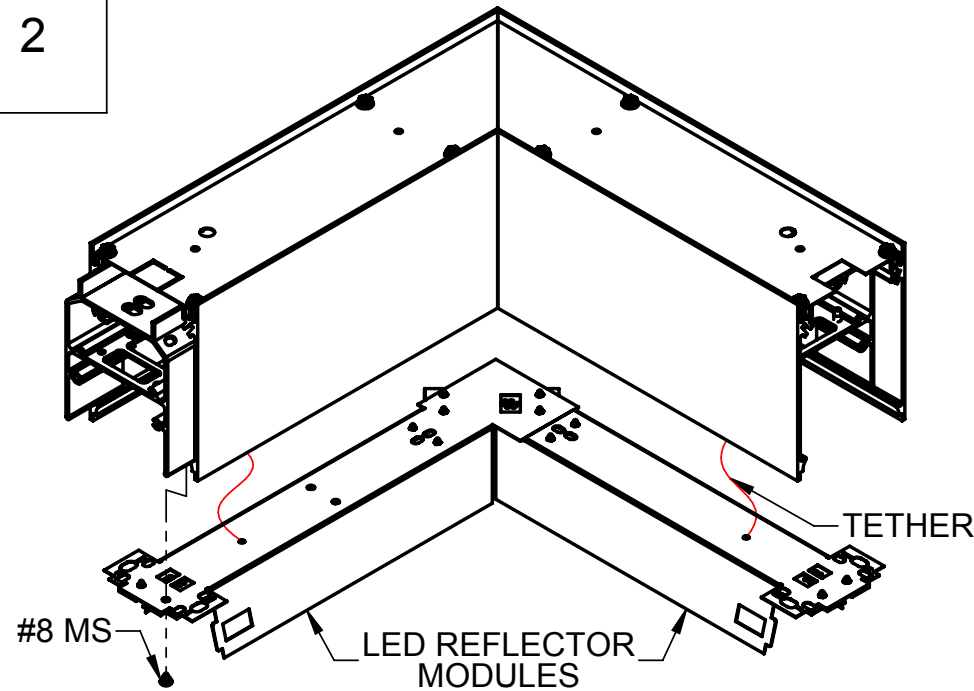

REMOVE LED REFLECTOR MODULES OF CORNER FIXTURE BY REMOVING 8-32 MACHINE SCREWS. ALLOW MODULES TO HANG DOWN ON NYLON TETHERS.

3

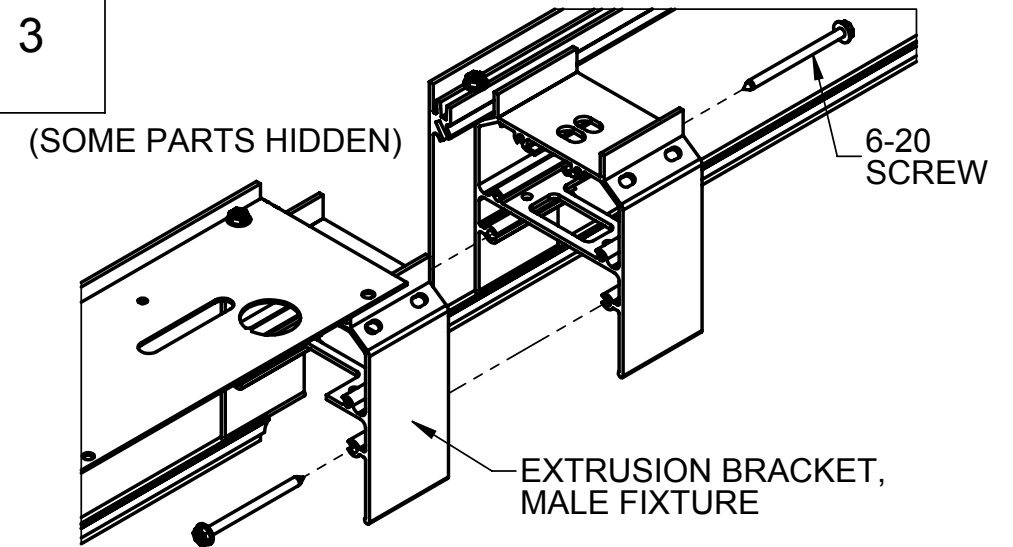

JOIN CORNER FIXTURE WITH MOUNTED LINEAR FIXTURE BY ALIGNING THE EXTRUSION BRACKET AND INSERTING IT INTO THE ADJOINING FIXTURE. SECURE WITH 6-20 X 2" LONG HEX HEAD SCREWS. DO NOT OVERTIGHTEN WITH POWER DRILL. ROUTE BRANCH CIRCUIT WIRING THROUGH FIXTURE JOINT.

MOUNT LINEAR FIXTURE AT OTHER END OF CORNER, REPEATING PROCEDURE AT JOINT.

4

REPLACE LED REFLECTOR MODULE. CLEAN FIXTURE EXTERIORS WITH A GENERAL WINDOW CLEANER.

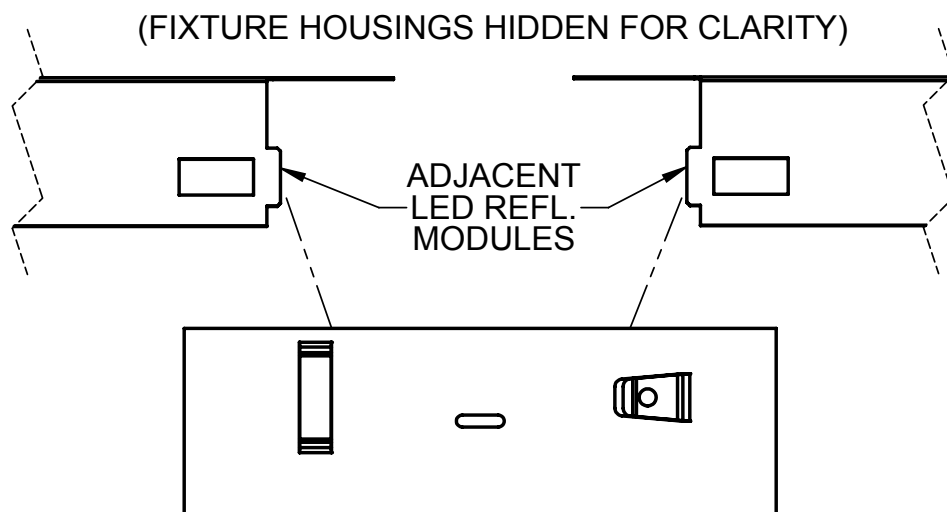

ROW JOINT COVER PLATE

ATTACH ROW JOINT COVER PLATES, AS SHOWN, AT BOTH FIXTURE JOINTS.

5

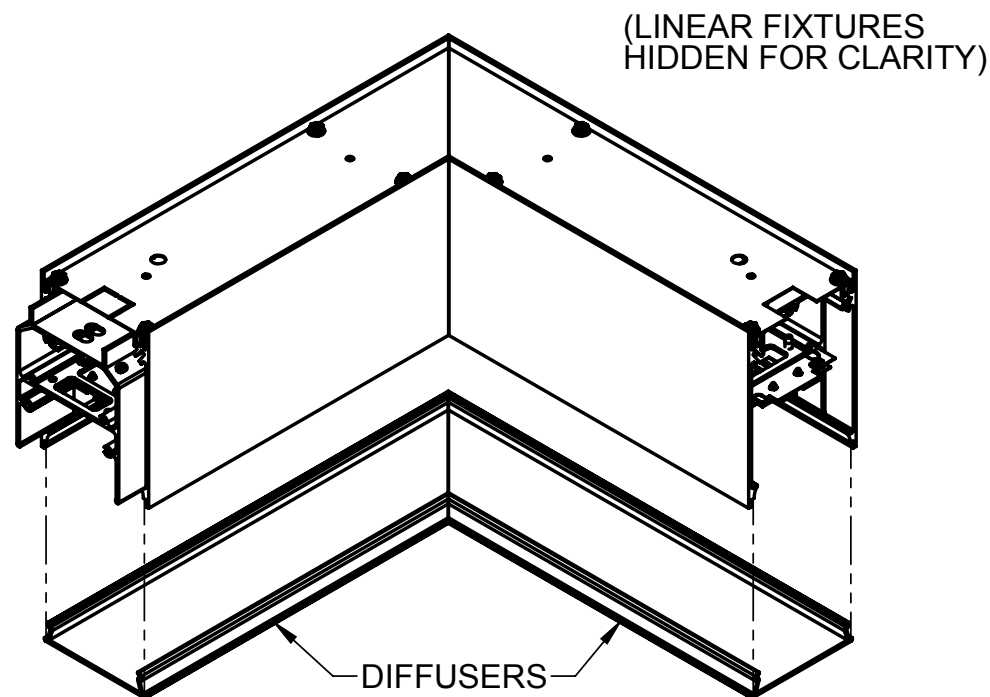

SNAP DIFFUSERS INTO BOTTOM OF HOUSING AS SHOWN. TO REMOVE, INSERT SCREWDRIVER OR FLAT HEAD PRY TOOL INTO SIDE OF HOUSING AND PULL DOWN.

LK DUST COVER OPTION (SHIPPED SEPARATELY): PLACE DUST COVER ONTO LED REFLECTOR MODULE ASSEMBLY. MAGNETS HOLD THE DUST COVER IN PLACE.