

WARNING: Fixtures must be grounded in accordance with local codes or the National Electrical Code. Failure to do so may result in serious personal injury.

KEEP THIS SHEET FOR FUTURE REFERENCE.

Tools Required: □ Flat Blade Screwdriver

INSTALLATION INSTRUCTIONS: ⚠ Make certain electrical supply is OFF before starting fixture installation.

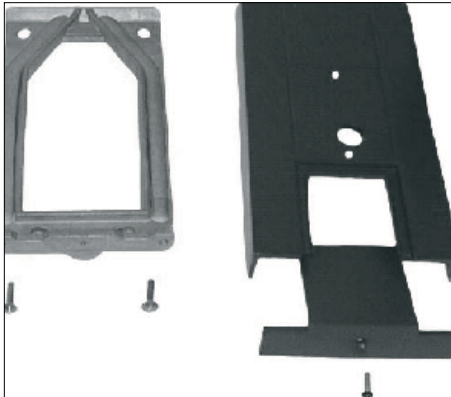

1. Remove wiring inspection cover from wall plate and wall mount cover. Apply a continuous bead of silicone sealant compound into the wall plate groove.

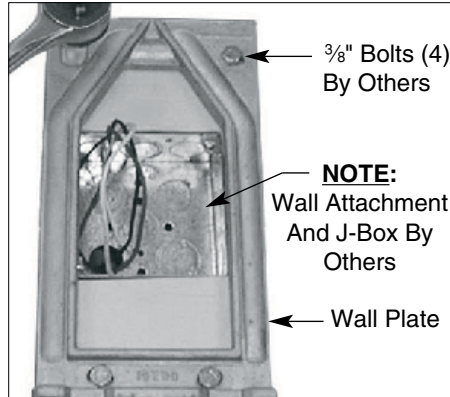

2. Allow sealant to extend well above the wall plate surface to ensure a proper seal. Securely mount wall plate over junction box, (by others), on wall - **hardware provided by others.**

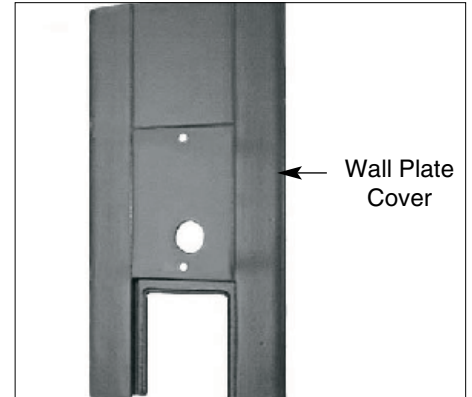

3. **Caution: Structural integrity of mounting plate attachment to wall is by others.** The fixture arm cover plate assembly is hooked to the wall mounting plate and secured with stainless steel screws provided. Field splices are made at the opening in the cover plate. (See Fixture Wall Mount Installation Instructions)

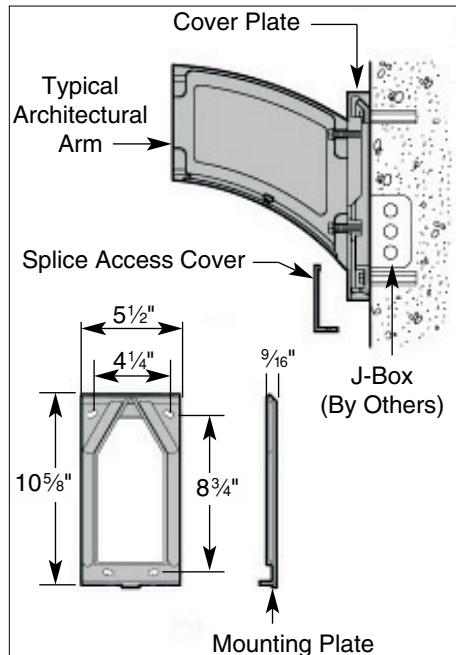

4. Hang fixture from wall plate and secure with screws.



5. Install wiring inspection cover and secure with screws.

For warranty see: currentlighting.com/kimlighting

ECN 100715008

Status 3

Part No. 93016195