

INSTALLATION INSTRUCTIONS

CATALOG NUMBER
PKWM

PARKWAY SQUARE - PEDESTRIAN SCALE LUMINARE

VERTICAL OPTICAL SYSTEMS: GLA, GR3, GR5, -3, -5, IL55.

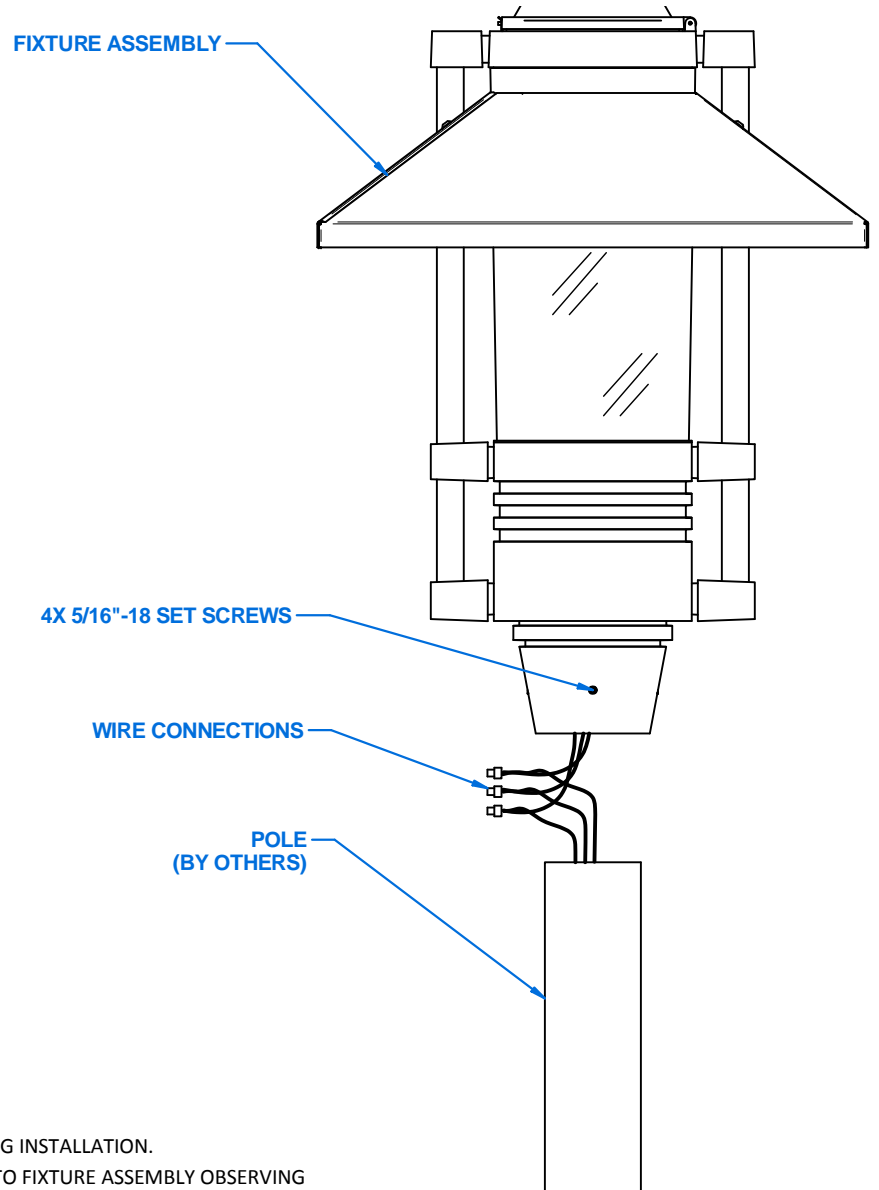

POST TOP MOUNTING - INSTALLATION STEPS:

1. MAKE CERTAIN ELECTRICAL POWER IS **OFF** BEFORE STARTING INSTALLATION.
2. MAKE WIRE CONNECTIONS FROM INCOMING WIRE LEADS TO FIXTURE ASSEMBLY OBSERVING POLARITY (WHITE TO COMMON, BLACK TO HOT AND GREEN TO GROUND). NOTE ASSEMBLY MUST BE GROUNDED TO THE INCOMING EQUIPMENT'S GROUND SUPPLY.
3. PLACE WIRING IN POLE AND SLIP FIXTURE OVER POLE AND USE 5/32" HEX DRIVER TO SECURE FIXTURE TO POLE WITH 4X 5/16" SET SCREWS.
4. INSTALL LAMP PER INSTRUCTIONS ON PAGE 4 IF NECESSARY.
5. TURN ON ELECTRICAL POWER TO CHECK FIXTURE OPERATION.
6. INSTALLATION COMPLETE.

WALL MOUNTING INSTRUCTIONS

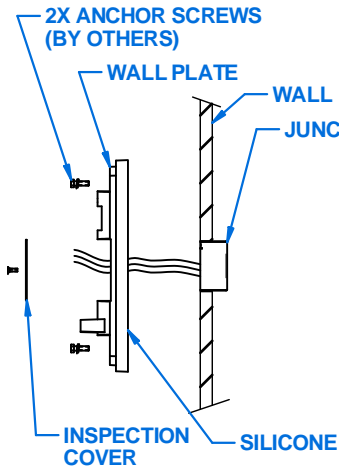

WALL PLATE

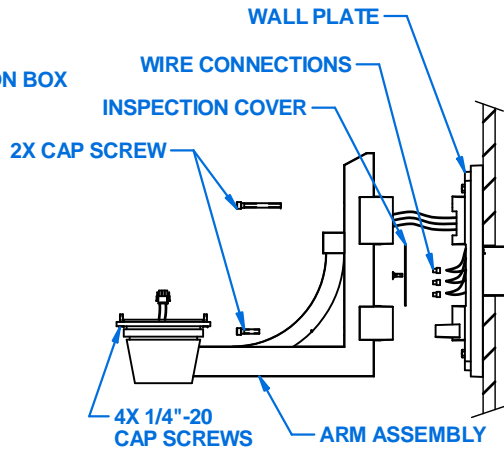

ARM TO WALL PLATE

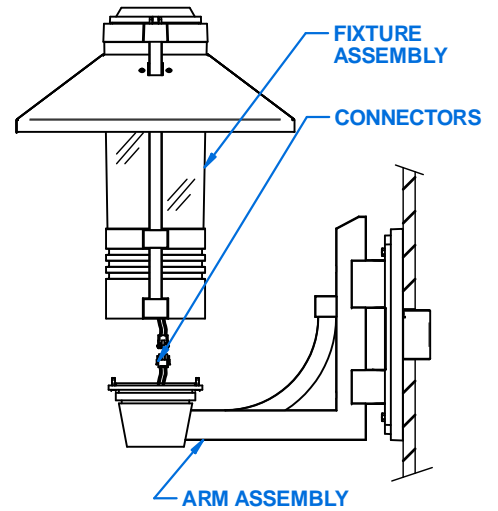

FIXTURE ASSEMBLY

WALL MOUNT ARM - INSTALLATION STEPS:

1. MAKE CERTAIN ELECTRICAL POWER IS **OFF** BEFORE STARTING INSTALLATION.
2. SILICONE ALL AROUND WALL PLATE AT MOUNTING SURFACE, SECURE WALL PLATE TO WALL WITH 2 ANCHOR BOLTS (MOUNTING HARDWARE BY OTHERS). PULL INCOMING WIRE LEADS THROUGH WIRE-WAY.
3. PULL WIRES FROM ARM ASSEMBLY THROUGH WALL PLATE SO THEY ARE ACCESSIBLE AT THE WIRE-WAY INSPECTION HOLE. USE 5/16" HEX DRIVER TO SECURE ARM ASSEMBLY TO WALL PLATE WITH 2X 3/8"-16 SOCKET HEAD CAP SCREWS.
4. MAKE WIRE CONNECTIONS FROM INCOMING WIRE LEADS TO FIXTURE ASSEMBLY OBSERVING POLARITY (WHITE TO COMMON, BLACK TO HOT AND GREEN TO GROUND). NOTE ASSEMBLY MUST BE GROUNDED TO THE INCOMING EQUIPMENT'S GROUND SUPPLY.
5. USE 5/32" HEX DRIVER TO SECURE FIXTURE ASSEMBLY TO ARM ASSEMBLY WITH 4X CAPTIVE 1/4"-20 X 3/4" SOCKET HEAD CAP SCREWS.
6. PLACE WIRING IN JUNCTION BOX AND USE 5/32" HEX DRIVER TO SECURE INSPECTION COVER.
7. INSTALL LAMP PER INSTRUCTIONS ON PAGE 4 IF NECESSARY.
8. TURN ON ELECTRICAL POWER TO CHECK FIXTURE OPERATION.
9. INSTALLATION COMPLETE.

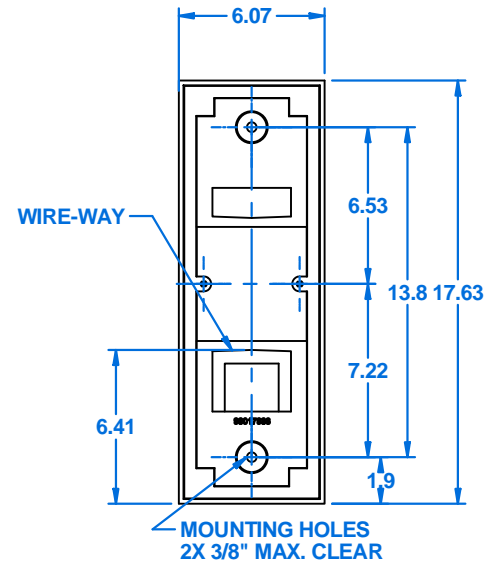

BACK VIEW

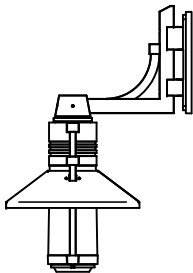

PSWM-BD

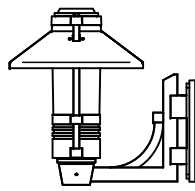

PSWM-TD

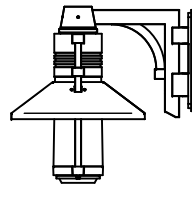

PSWM-BU

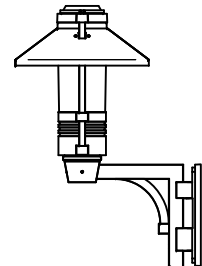

PSWM-TU

POLE ARM MOUNTING INSTRUCTIONS

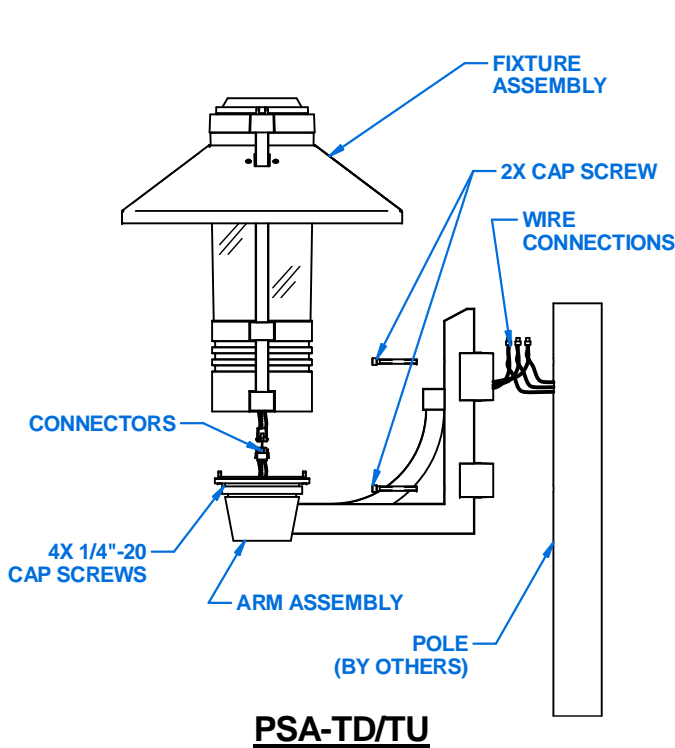

PSA-TD/TU

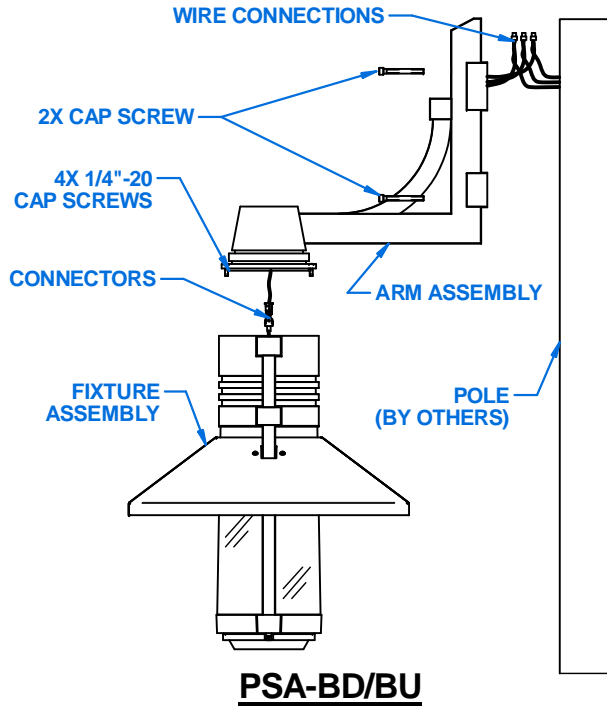

PSA-BD/BU

POLE MOUNT ARM - INSTALLATION STEPS:

1. MAKE CERTAIN ELECTRICAL POWER IS **OFF** BEFORE STARTING INSTALLATION.
2. MAKE WIRE CONNECTIONS FROM INCOMING WIRE LEADS TO FIXTURE ASSEMBLY OBSERVING POLARITY (WHITE TO COMMON, BLACK TO HOT AND GREEN TO GROUND). NOTE ASSEMBLY MUST BE GROUNDED TO THE INCOMING EQUIPMENT'S GROUND SUPPLY.
3. USE 5/16" HEX DRIVER TO SECURE ARM ASSEMBLY TO POLE WITH 2X 3/8" CAP SCREWS.
4. USE 5/32" HEX DRIVER TO SECURE FIXTURE ASSEMBLY TO ARM ASSEMBLY WITH 4X CAPTIVE 1/4"-20 X 3/4" SOCKET HEAD CAP SCREWS.
5. INSTALL LAMP PER INSTRUCTIONS ON PAGE 4 IF NECESSARY.
6. TURN ON ELECTRICAL POWER TO CHECK FIXTURE OPERATION.
7. INSTALLATION COMPLETE.

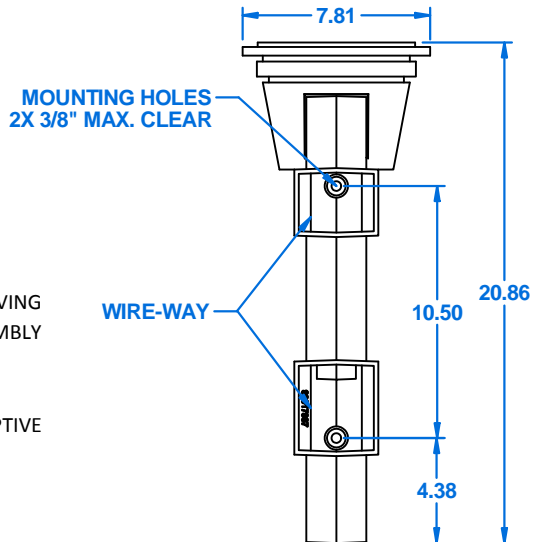

BACK VIEW

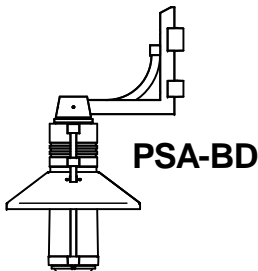

PSA-TD

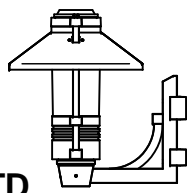

PSA-BU

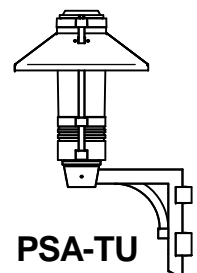
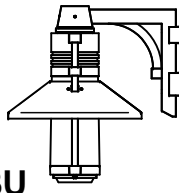

PSA-TU

LAMP/BALLAST SERVICE INSTRUCTIONS

RE-LAMPING – VERTICAL:

1. MAKE CERTAIN ELECTRICAL POWER IS **OFF** BEFORE STARTING INSTALLATION.
2. PULL LATCH AWAY FROM LAMP COMPARTMENT LID TO RELEASE AND OPEN LID.
3. INSTALL LAMP (BY OTHERS) AND CLOSE LID UNTIL LATCH IS SECURELY ENGAGED.
4. TURN ON ELECTRICAL POWER TO CHECK FIXTURE OPERATION.
5. INSTALLATION COMPLETE.

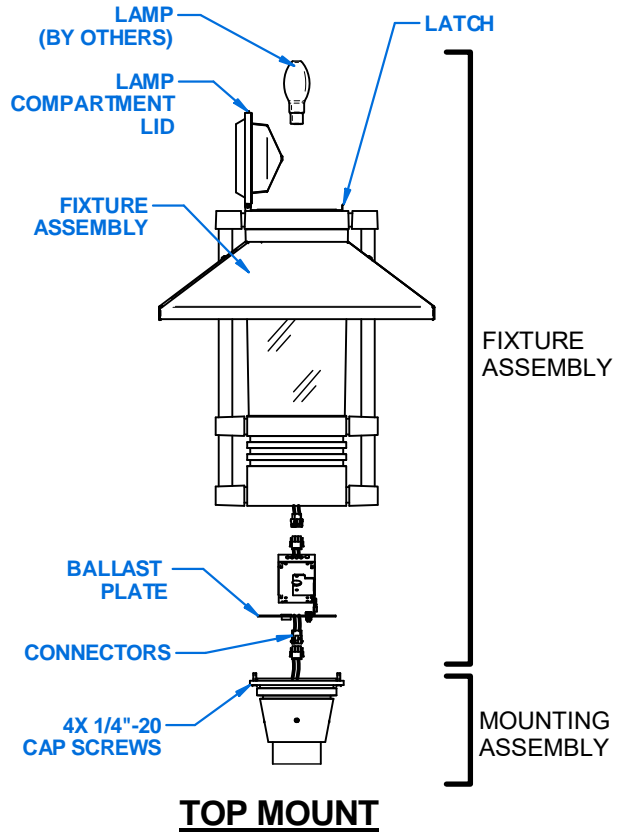

BALLAST SERVICING – VERTICAL

1. MAKE CERTAIN ELECTRICAL POWER IS **OFF** BEFORE STARTING INSTALLATION.
2. USE A 5/32" HEX DRIVER TO RELEASE FIXTURE ASSEMBLY FROM MOUNTING ASSEMBLY BY LOOSENING 4X CAPTIVE 1/4-20 X 3/4" SOCKET HEAD CAP SCREWS.
3. LIFT FIXTURE ASSEMBLY, UNPLUG WIRE CONNECTORS AND REMOVE FROM MOUNTING ASSEMBLY.
4. USE A #3 PHILIPS SCREW DRIVER TO LOOSEN 2X 1/4-20 X 3/8" PHILIPS SCREWS AT BALLAST PLATE, ONCE THE SCREWS ARE LOOSENED, ROTATE BALLAST PLATE ALONG KEYHOLE SLOTS TO DISENGAGE BALLAST ASSEMBLY FROM FIXTURE ASSEMBLY.
5. UNPLUG CONNECTORS AND REPLACE BALLAST.
6. PLUG IN ALL CONNECTORS AND PLACE BALLAST INTO FIXTURE ASSEMBLY USING KEYHOLE SLOTS AND 2X 1/4-20 X 3/8 PHILIPS SCREWS. USE A #3 PHILIPS SCREW DRIVER TO SECURELY TIGHTEN 2X 1/4-20 X 3/8 PHILIPS SCREWS AT BALLAST PLATE.
7. PLUG IN WIRE CONNECTORS AND USE 5/32" HEX DRIVER TO SECURE FIXTURE ASSEMBLY TO MOUNTING ASSEMBLY WITH 4X CAPTIVE 1/4-20 X 3/4" SOCKET HEAD CAP SCREWS.
8. TURN ON ELECTRICAL POWER TO CHECK FIXTURE OPERATION.
9. INSTALLATION COMPLETE.

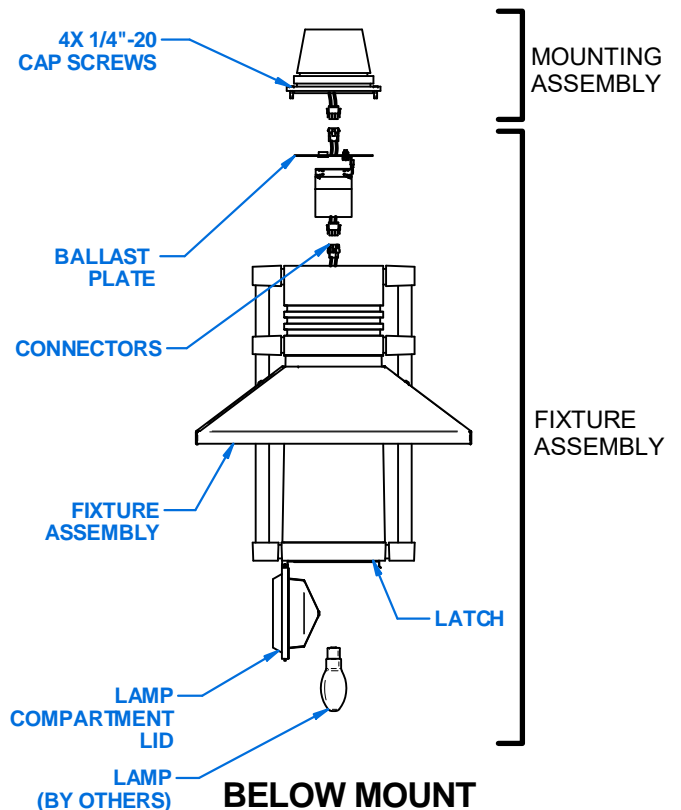

INSTALLATION INSTRUCTIONS

PARKWAY SQUARE - PEDESTRIAN SCALE LUMINARE

HORIZONTAL OPTICAL SYSTEMS: H2, H3, H4, H5, T2, T3, T4, T5.

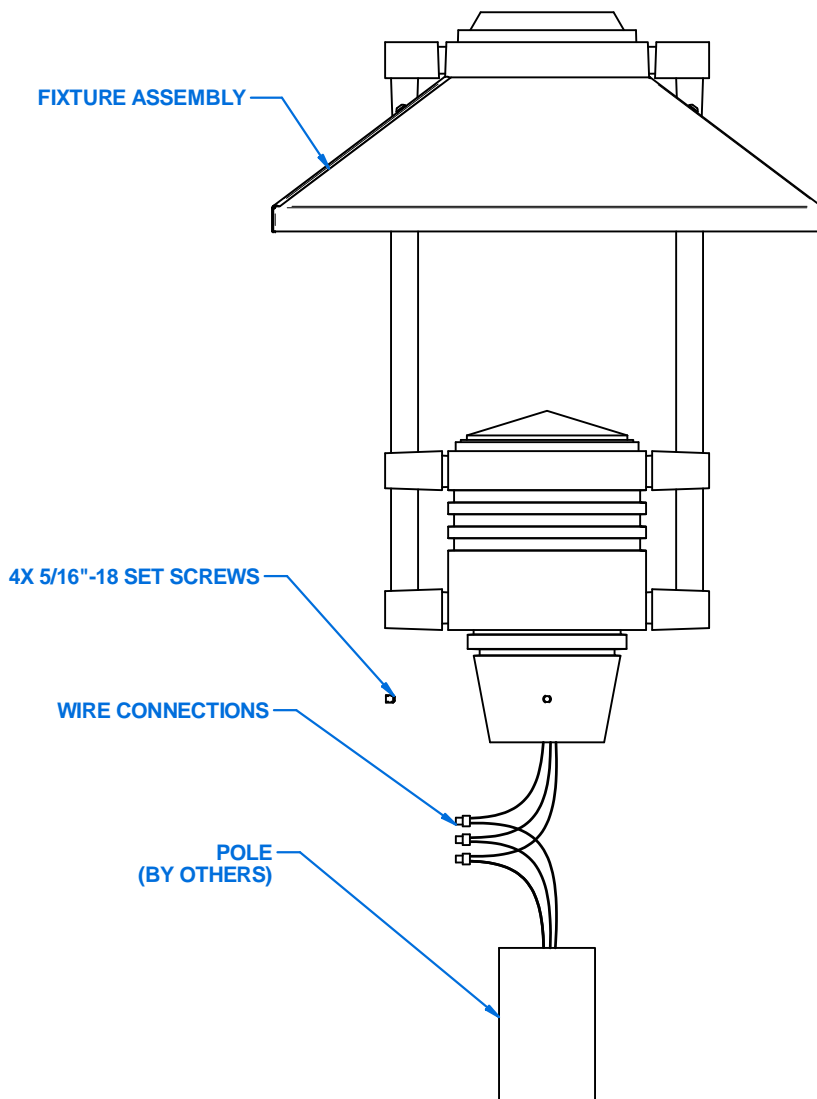

POST TOP MOUNTING - INSTALLATION STEPS:

1. MAKE CERTAIN ELECTRICAL POWER IS **OFF** BEFORE STARTING INSTALLATION.
2. MAKE WIRE CONNECTIONS FROM INCOMING WIRE LEADS TO FIXTURE ASSEMBLY OBSERVING POLARITY (WHITE TO COMMON, BLACK TO HOT AND GREEN TO GROUND). NOTE ASSEMBLY MUST BE GROUNDED TO THE INCOMING EQUIPMENT'S GROUND SUPPLY.
3. PLACE WIRING IN POLE AND SLIP FIXTURE OVER POLE AND USE 5/32" HEX DRIVER TO SECURE FIXTURE TO POLE WITH 4X 5/16" SET SCREWS.
4. INSTALL LAMP PER INSTRUCTIONS ON PAGE 4 IF NECESSARY.
5. TURN ON ELECTRICAL POWER TO CHECK FIXTURE OPERATION.
6. INSTALLATION COMPLETE.

WALL MOUNTING INSTRUCTIONS

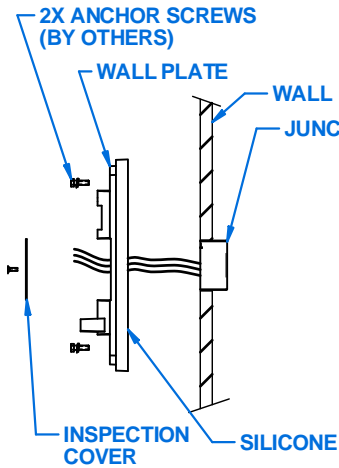

WALL PLATE

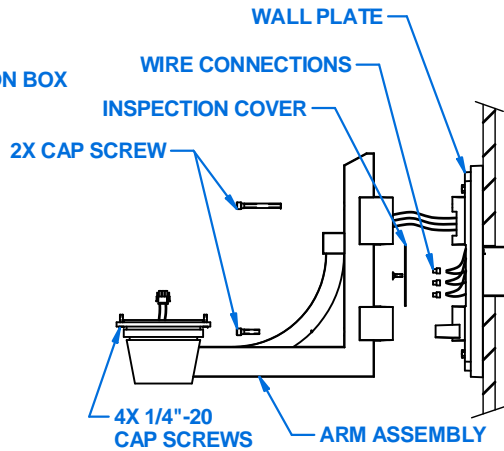

ARM TO WALL PLATE

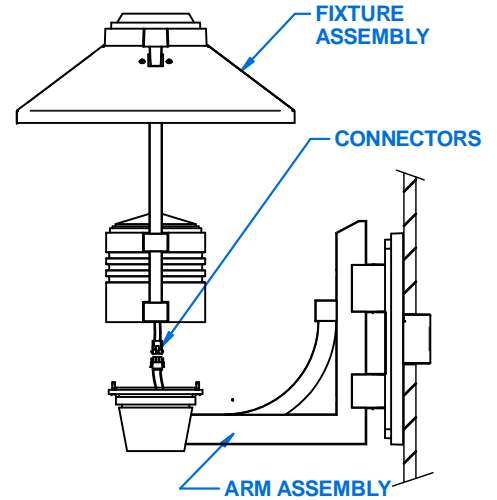

FIXTURE ASSEMBLY

WALL MOUNT ARM - INSTALLATION STEPS:

1. MAKE CERTAIN ELECTRICAL POWER IS **OFF** BEFORE STARTING INSTALLATION.
2. SILICONE ALL AROUND WALL PLATE AT MOUNTING SURFACE, SECURE WALL PLATE TO WALL WITH 2 ANCHOR BOLTS (MOUNTING HARDWARE BY OTHERS). PULL INCOMING WIRE LEADS THROUGH WIRE-WAY.
3. PULL WIRES FROM ARM ASSEMBLY THROUGH WALL PLATE SO THEY ARE ACCESSIBLE AT THE WIRE-WAY INSPECTION HOLE. USE 5/16" HEX DRIVER TO SECURE ARM ASSEMBLY TO WALL PLATE WITH 2X 3/8 SOCKET HEAD CAP SCREWS.
4. MAKE WIRE CONNECTIONS FROM INCOMING WIRE LEADS TO FIXTURE ASSEMBLY OBSERVING POLARITY (WHITE TO COMMON, BLACK TO HOT AND GREEN TO GROUND). NOTE ASSEMBLY MUST BE GROUNDED TO THE INCOMING EQUIPMENT'S GROUND SUPPLY.
5. USE 5/32" HEX DRIVER TO SECURE FIXTURE ASSEMBLY TO ARM ASSEMBLY WITH 4X CAPTIVE 1/4-20 X 3/4" CAP SCREWS.
6. PLACE WIRING IN JUNCTION BOX AND USE 5/32" HEX DRIVER TO SECURE INSPECTION COVER.
7. INSTALL LAMP PER INSTRUCTIONS ON PAGE 4 IF NECESSARY.
8. TURN ON ELECTRICAL POWER TO CHECK FIXTURE OPERATION.
9. INSTALLATION COMPLETE.

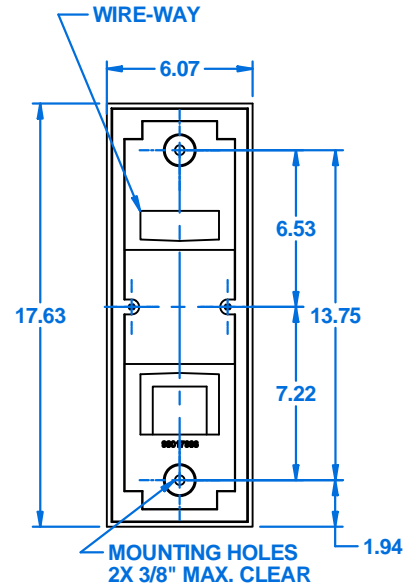

BACK VIEW

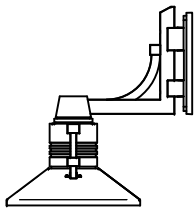

PSWM-BD

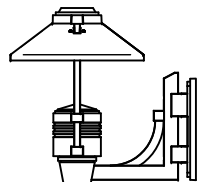

PSWM-TD

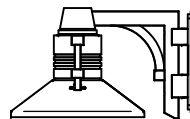

PSWM-BU

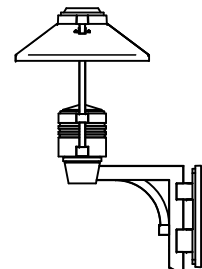

PSWM-TU

POLE ARM MOUNTING INSTRUCTIONS

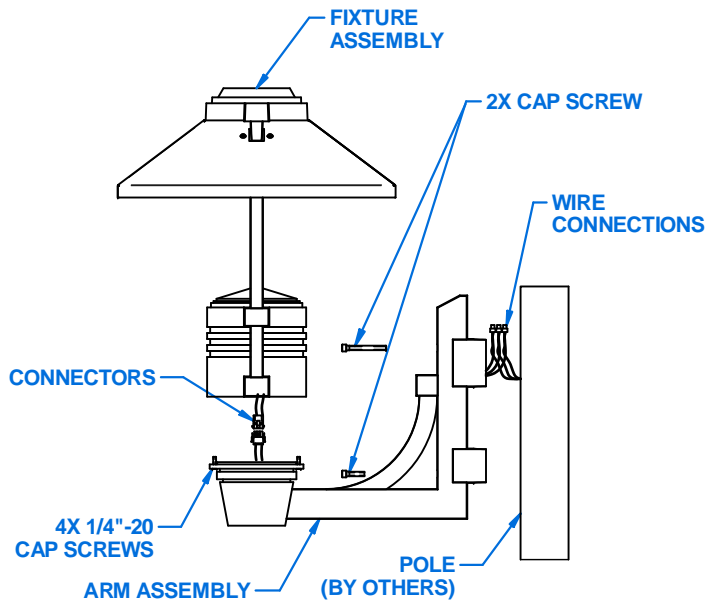

PSA-TD/TU

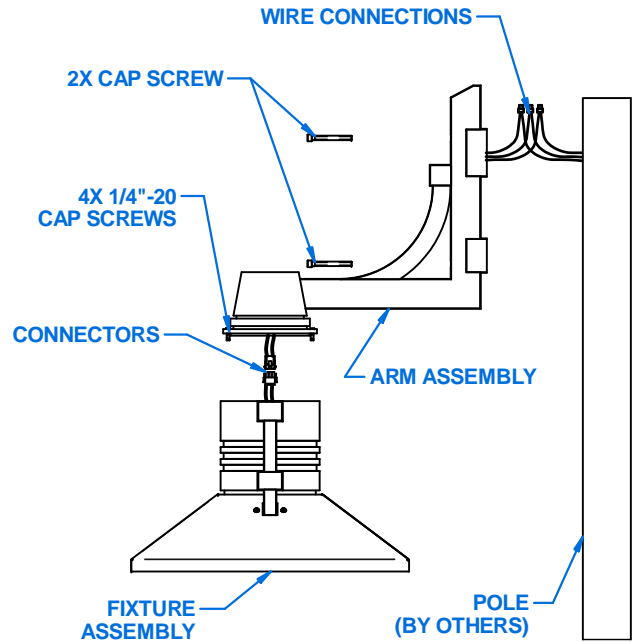

PSA-BD/BU

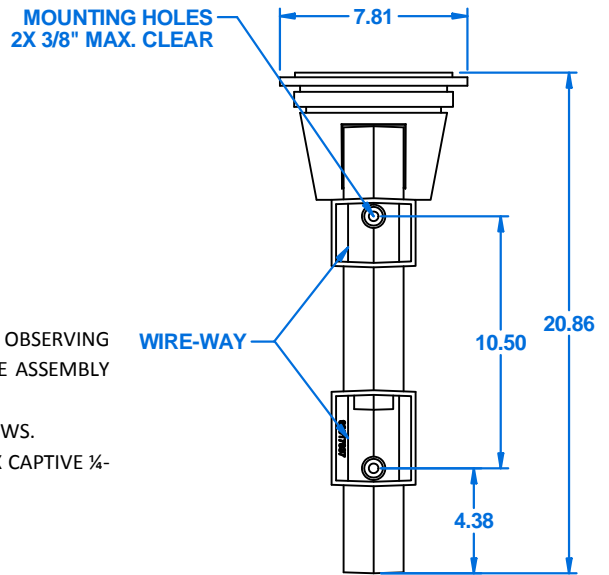

BACK VIEW

POLE MOUNT ARM - INSTALLATION STEPS:

1. MAKE CERTAIN ELECTRICAL POWER IS **OFF** BEFORE STARTING INSTALLATION.
2. MAKE WIRE CONNECTIONS FROM INCOMING WIRE LEADS TO FIXTURE ASSEMBLY OBSERVING POLARITY (WHITE TO COMMON, BLACK TO HOT AND GREEN TO GROUND). NOTE ASSEMBLY MUST BE GROUNDED TO THE INCOMING EQUIPMENT'S GROUND SUPPLY.
3. USE 5/16" HEX DRIVER TO SECURE ARM ASSEMBLY TO POLE WITH 2X 3/8" CAP SCREWS.
4. USE 5/32" HEX DRIVER TO SECURE FIXTURE ASSEMBLY TO ARM ASSEMBLY WITH 4X CAPTIVE 1/4-20 X 3/4" CAP SCREWS.
5. INSTALL LAMP PER INSTRUCTIONS ON PAGE 4 IF NECESSARY.
6. TURN ON ELECTRICAL POWER TO CHECK FIXTURE OPERATION.
7. INSTALLATION COMPLETE.

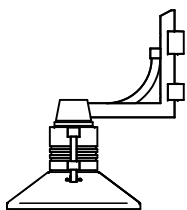

PSA-BD

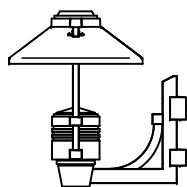

PSA-TD

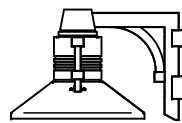

PSA-BU

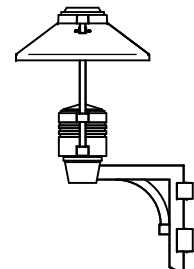

PSA-TU

LAMP/BALLAST SERVICE INSTRUCTIONS

RE-LAMPING – HORIZONTAL

1. MAKE CERTAIN ELECTRICAL POWER IS **OFF** BEFORE STARTING INSTALLATION.
2. PULL 2X LATCHES ON UNDERSIDE OF LENS FRAME RELEASING LAMP COMPARTMENT TO ACCESS LAMP.
3. REPLACE LAMP.
4. CLOSE LAMP COMPARTMENT UNTIL LATCHES ARE SECURELY ENGAGED.
5. TURN ON ELECTRICAL POWER TO CHECK FIXTURE OPERATION.
6. INSTALLATION COMPLETE.

BALLAST SERVICING – VERTICAL AND HORIZONTAL

1. MAKE CERTAIN ELECTRICAL POWER IS **OFF** BEFORE STARTING INSTALLATION.
2. USE 5/32" HEX DRIVER TO RELEASE FIXTURE ASSEMBLY FROM MOUNTING ASSEMBLY BY LOOSENING 4X CAPTIVE 1/4"-20 X 3/4" SOCKET HEAD CAP SCREWS.
3. LIFT FIXTURE ASSEMBLY AWAY FROM MOUNTING ASSEMBLY, UNPLUG WIRE CONNECTIONS.
4. USE A #3 PHILIPS SCREW DRIVER TO LOOSEN 2X 1/4"-20 X 3/8 PHILIPS SCREWS AT BALLAST PLATE, ONCE THE SCREWS ARE LOOSENED, ROTATE BALLAST PLATE ALONG KEYHOLE SLOTS TO DISENGAGE BALLAST ASSEMBLY FROM FIXTURE ASSEMBLY.
5. UNPLUG CONNECTORS AND REPLACE BALLAST.
6. PLUG IN ALL CONNECTORS AND PLACE BALLAST INTO FIXTURE ASSEMBLY USING KEYHOLE SLOTS AND 2X 1/4"-20 X 3/8 PHILIPS SCREWS. USE A #3 PHILIPS SCREWDRIVER TO SECURELY TIGHTEN 2X 1/4"-20 X 3/8 PHILIPS SCREWS AT BALLAST PLATE.
7. PLUG IN WIRE CONNECTORS AND USE 5/32" HEX DRIVER TO SECURE FIXTURE ASSEMBLY TO MOUNTING ASSEMBLY WITH 4X CAPTIVE 1/4"-20 X 3/4" SOCKET HEAD CAP SCREWS.
8. TURN ON ELECTRICAL POWER TO CHECK FIXTURE OPERATION.
9. INSTALLATION COMPLETE.

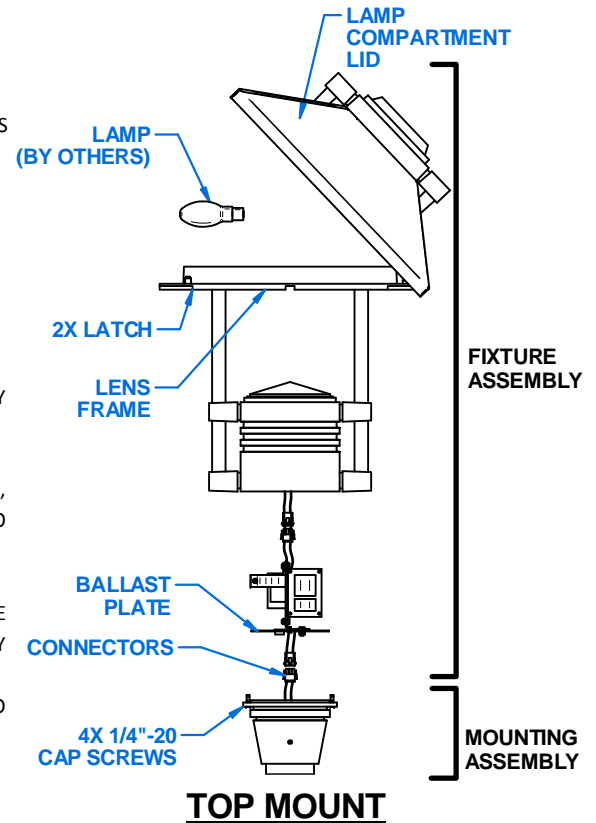

LED SERVICE INSTRUCTIONS

EMITTER DECK SERVICING

1. MAKE CERTAIN ELECTRICAL POWER IS **OFF** BEFORE STARTING INSTALLATION.
2. PULL 2X LATCHES ON UNDERSIDE OF LENS FRAME RELEASING LAMP COMPARTMENT LID TO ACCESS LAMP COMPARTMENT.
3. FIRMLY HOLD EMITTER DECK ASSEMBLY WHILE USING A #3 PHILIPS SCREWDRIVER TO REMOVE 4X 1/4"-20 SCREWS ON UNDERSIDE OF EMITTER DECK ASSEMBLY. ONCE SCREWS ARE REMOVED, LIFT EMITTER DECK ASSEMBLY OUT OF LAMP COMPARTMENT AND UNPLUG WIRE CONNECTORS.
4. USE A #3 PHILIPS SCREWDRIVER TO REMOVE 2X 1/4"-20 SCREWS AND LIFT DRIVER TRAY AWAY FROM CARRIER PLATE.
5. REPLACE MICROEMITTER(S), DRIVER, SURGE PROTECTOR OR LIFESHIELD AS NEEDED.
6. PLACE DRIVER TRAY ONTO CARRIER PLATE AND USE A #3 PHILIPS SCREWDRIVER TO SECURELY FASTEN THE DRIVER TRAY TO THE CARRIER PLATE WITH 2X 1/4"-20 PHILIPS SCREWS.
7. PLUG IN ALL CONNECTORS AND PLACE EMITTER DECK ASSEMBLY INTO FIXTURE. FIRMLY HOLD EMITTER DECK ASSEMBLY WHILE USING A #3 PHILIPS SCREWDRIVER TO SECURE THE EMITTER DECK ASSEMBLY TO THE LAMP COMPARTMENT WITH 4X 1/4"-20 PHILIPS SCREWS.
8. CLOSE LAMP COMPARTMENT UNTIL LATCHES ARE SECURELY ENGAGED.
9. TURN ON ELECTRICAL POWER TO CHECK FIXTURE OPERATION.
10. INSTALLATION COMPLETE.

