

INSTALLATION INSTRUCTIONS

CATALOG NUMBER
PKSP

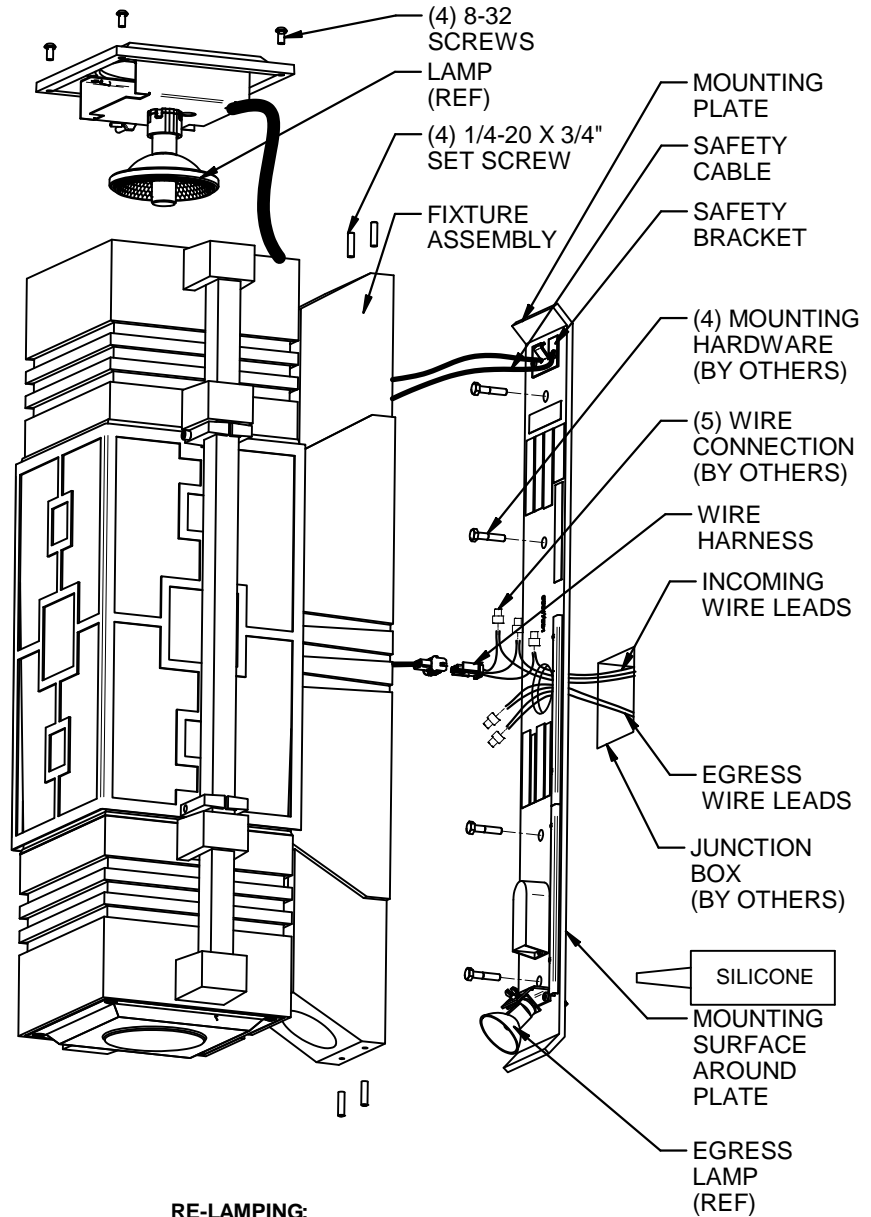
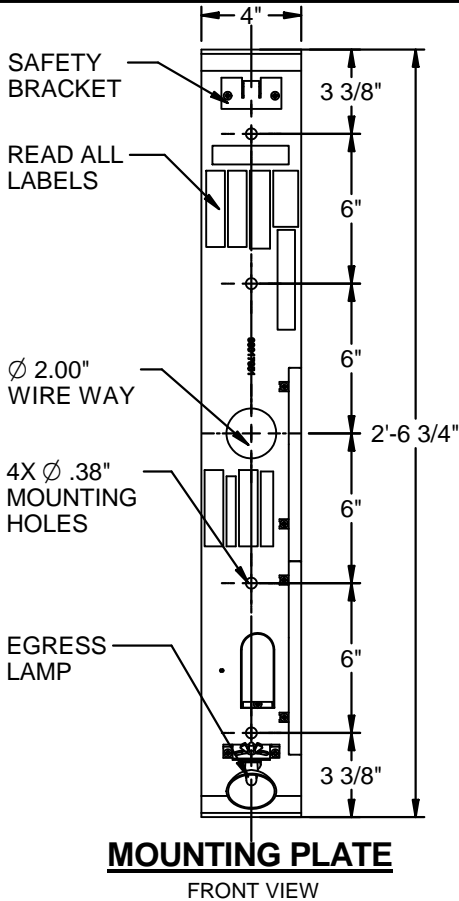

NOTE:

THIS PRODUCT MUST BE INSTALLED IN ACCORDANCE WITH THE APPLICABLE INSTALLATION CODE BY A PERSON FAMILIAR WITH THE CONSTRUCTION AND OPERATION OF THE PRODUCT AND THE HAZARDS INVOLVED.

INSTALLATION

1. **TURN OFF POWER.**
2. READ ALL WARNING LABELS ON THE MOUNTING PLATE.
3. PULL INCOMING WIRE LEADS THROUGH WIREWAY AND SECURE MOUNTING PLATE TO MOUNTING SURFACE. NOTE: TO BE MOUNTED INDEPENDENT OF JUNCTION BOX. **(MOUNTING HARDWARE BY OTHERS)**
4. APPLY SILICONE ALL AROUND MOUNTING PLATE WHERE PLATE MEETS THE MOUNTING SURFACE.
5. CONNECT INCOMING WIRES LEADS TO WIRE HARNESS WITH WIRE CONNECTIONS. **(WHITE TO WHITE, BLACK TO BLACK, GREEN TO GREEN.)**
6. SECURE SAFETY CABLE INTO THE SAFETY BRACKET ON THE MOUNTING PLATE
7. THE EGRESS SOCKET MUST BE WIRED TO A SEPARATE LISTED EMERGENCY CIRCUIT (LISTED TO UL924 AND CSA 141).
8. SECURE FIXTURE ASSEMBLY TO WALL PLATE WITH (4) 1/4-20 x 3/4" SET SCREWS.
9. TURN POWER ON AND CHECK FOR OPERATION.
10. **INSTALLATION COMPLETE.**

RE-LAMPING EGRESS LAMP

1. **TURN OFF POWER.**
2. LOOSEN (4) 1/4-20 x 3/4" SET SCREWS ON WALL CANOPY, MOVE FIXTURE ASSEMBLY AWAY FROM WALL PLATE.
3. REMOVE EGRESS LAMP GENTLY BY PULLING AWAY FROM EGRESS LAMP SOCKET.
4. REPLACE MR-16 LAMP.
5. TO RE-ASSEMBLE, REVERSE PROCEDURE.

RE-LAMPING:

1. **TURN OFF POWER.**
2. REMOVE (4) 8-32 SCREWS FROM TOP OR BOTTOM LID. PULL ON LID TO ACCESS LAMP SOCKET, AND INSTALL LAMP.
3. RETURN LID AND SCREWS TO ORIGINAL POSITION AND TIGHTEN SCREWS SECURELY.
4. **INSTALLATION COMPLETE.**

BALLAST SERVICING:

1. **TURN OFF POWER.**
2. LOOSEN (4) 1/4-20 x 3/4" SET SCREWS ON WALL CANOPY, DISCONNECT WIRING & MOVE FIXTURE AWAY FROM WALL PLATE. FIXTURE MUST BE SUPPORTED DURING SERVICING.
3. SERVICE BALLAST.
4. MAKE WIRE CONNECTIONS. (REFER TO WIRING DIAGRAM)
5. RETURN FIXTURE ASSEMBLY TO WALL PLATE AND SECURE WITH (4) 1/4-20 x 3/4" SET SCREWS.
6. **INSTALLATION COMPLETE.**

INSTALLATION INSTRUCTIONS

CATALOG NUMBER
PKSA

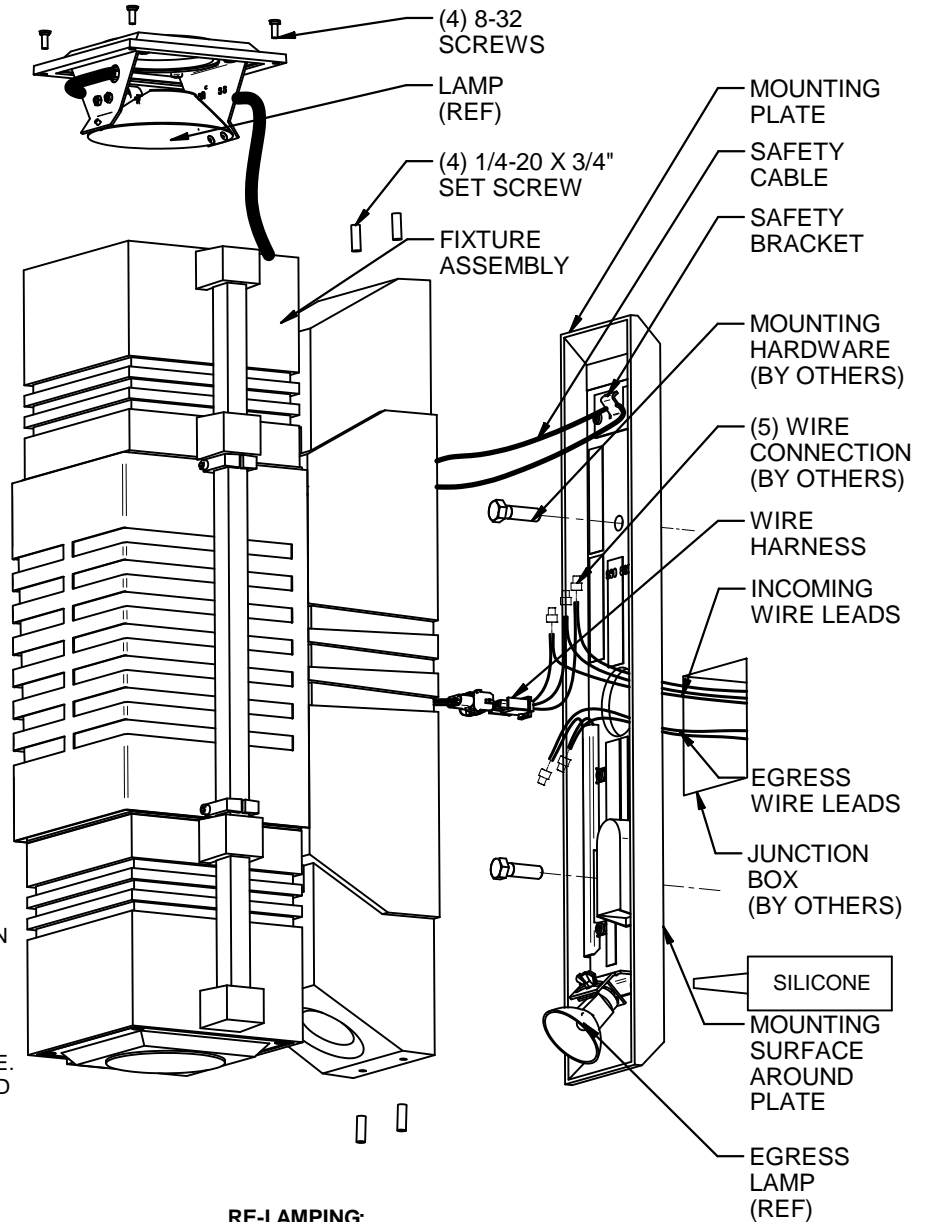
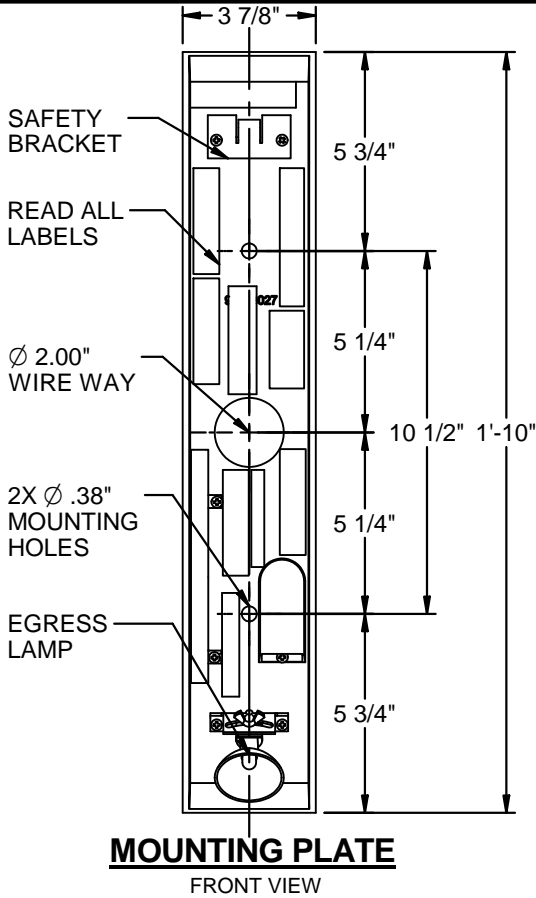

NOTE:

THIS PRODUCT MUST BE INSTALLED IN ACCORDANCE WITH THE APPLICABLE INSTALLATION CODE BY A PERSON FAMILIAR WITH THE CONSTRUCTION AND OPERATION OF THE PRODUCT AND THE HAZARDS INVOLVED.

INSTALLATION

1. **TURN OFF POWER.**
2. READ ALL WARNING LABELS ON THE MOUNTING PLATE.
3. PULL INCOMING WIRE LEADS THROUGH WIREWAY AND SECURE MOUNTING PLATE TO MOUNTING SURFACE.
NOTE: TO BE MOUNTED INDEPENDENT OF JUNCTION BOX. (MOUNTING HARDWARE BY OTHERS)
4. APPLY SILICONE ALL AROUND MOUNTING PLATE WHERE PLATE MEETS THE MOUNTING SURFACE.
5. CONNECT INCOMING WIRES LEADS TO WIRE HARNESS WITH WIRE CONNECTIONS. (WHITE TO WHITE, BLACK TO BLACK, GREEN TO GREEN.)
6. SECURE SAFETY CABLE INTO THE SAFETY BRACKET ON THE MOUNTING PLATE
7. THE EGRESS SOCKET MUST BE WIRED TO A SEPARATE LISTED EMERGENCY CIRCUIT (LISTED TO UL924 AND CSA 141).
8. SECURE FIXTURE ASSEMBLY TO WALL PLATE WITH (4) 1/4-20 x 3/4" SET SCREWS.
9. TURN POWER ON AND CHECK FOR OPERATION.
10. **INSTALLATION COMPLETE.**

RE-LAMPING EGRESS LAMP

1. **TURN OFF POWER.**
2. LOOSEN (4) 1/4-20 x 3/4" SET SCREWS ON WALL CANOPY, MOVE FIXTURE ASSEMBLY AWAY FROM WALL PLATE.
3. REMOVE EGRESS LAMP GENTLY BY PULLING AWAY FROM EGRESS LAMP SOCKET.
4. REPLACE MR-16 LAMP.
5. TO RE-ASSEMBLE, REVERSE PROCEDURE.

RE-LAMPING:

1. **TURN OFF POWER.**
2. REMOVE (4) 8-32 SCREWS FROM TOP OR BOTTOM LID. PULL ON LID TO ACCESS LAMP SOCKET, AND INSTALL LAMP.
3. RETURN LID AND SCREWS TO ORIGINAL POSITION AND TIGHTEN SCREWS SECURELY.
4. **INSTALLATION COMPLETE.**

BALLAST SERVICING:

1. **TURN OFF POWER.**
2. LOOSEN (4) 1/4-20 x 3/4" SET SCREWS ON WALL CANOPY, DISCONNECT WIRING & MOVE FIXTURE AWAY FROM WALL PLATE. FIXTURE MUST BE SUPPORTED DURING SERVICING.
3. SERVICE BALLAST.
4. MAKE WIRE CONNECTIONS. (REFER TO WIRING DIAGRAM)
5. RETURN FIXTURE ASSEMBLY TO WALL PLATE AND SECURE WITH (4) 1/4-20 x 3/4" SET SCREWS.
6. **INSTALLATION COMPLETE.**

WIRING DIAGRAMS

CATALOG NUMBER
PKSA

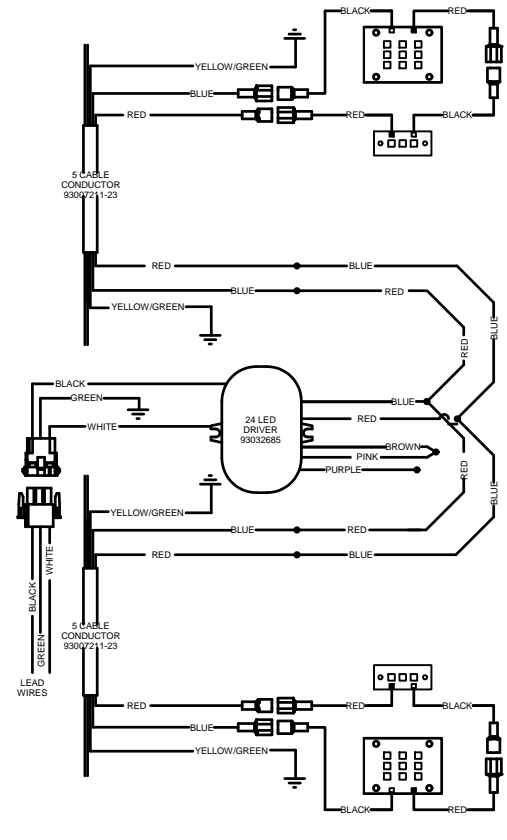
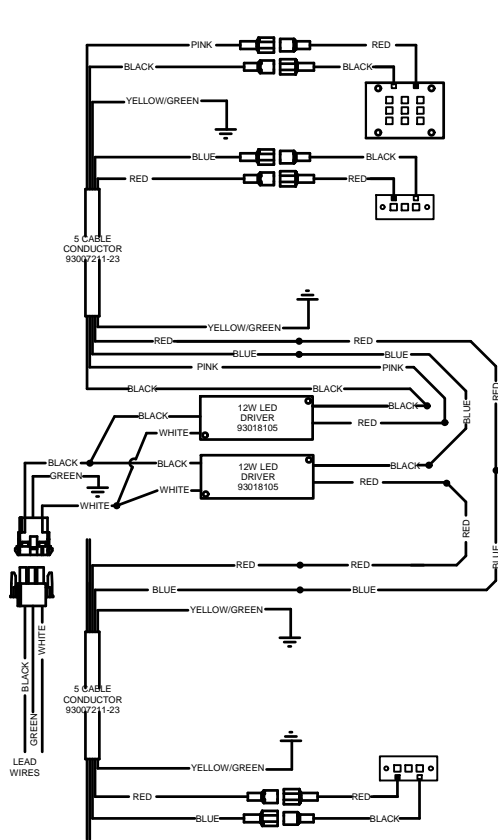
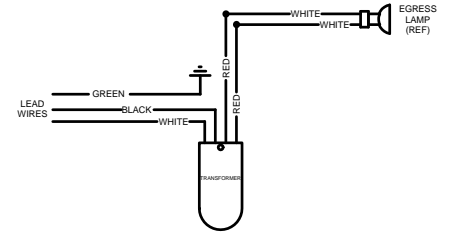
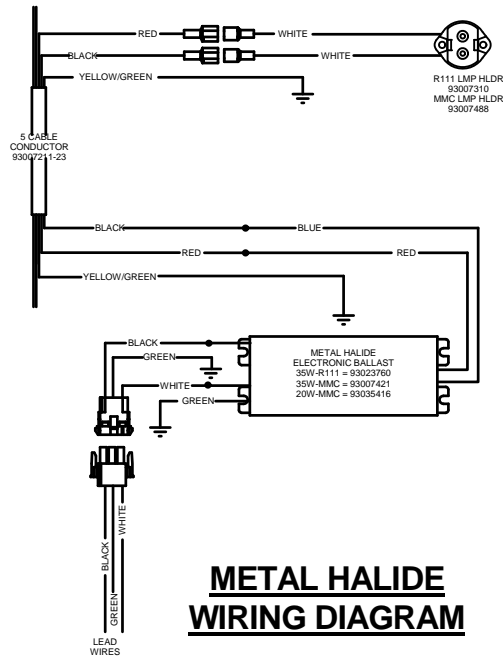
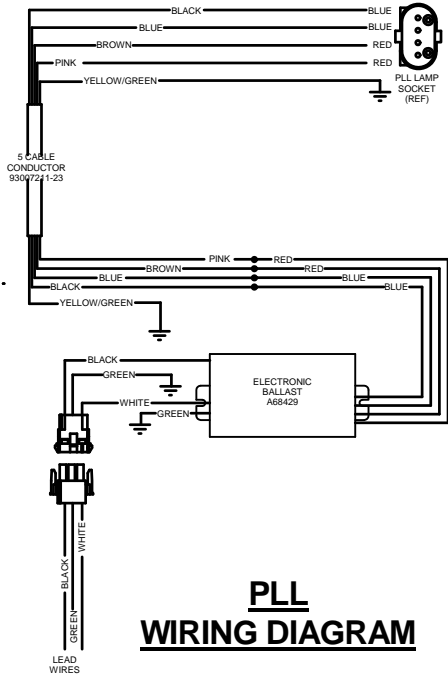

WIRING DIAGRAMS

CATALOG NUMBER
PKSP

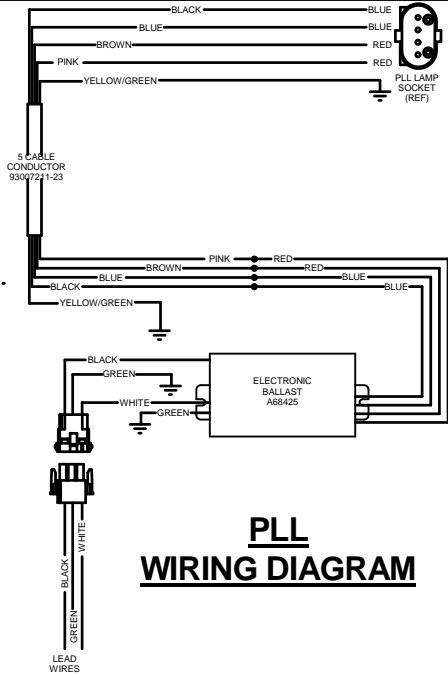

**PLL
WIRING DIAGM**

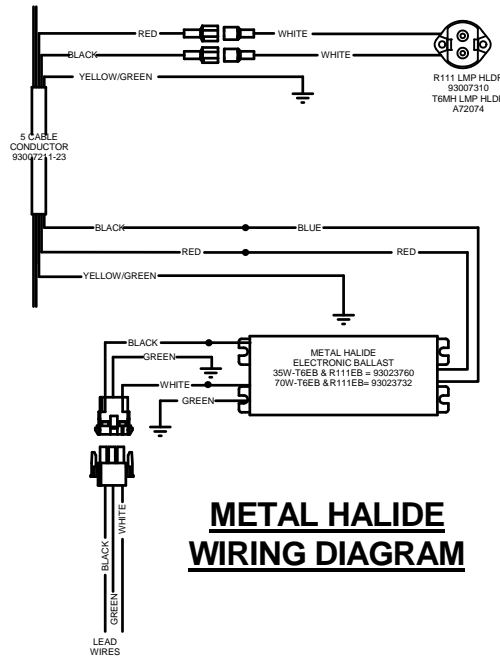

**METAL HALIDE
WIRING DIAGM**

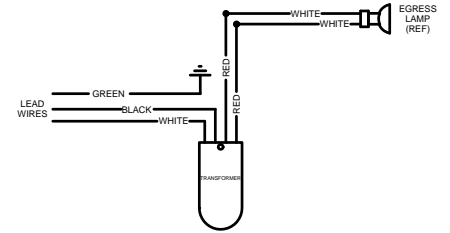

**EGRESS
WIRING DIAGM**

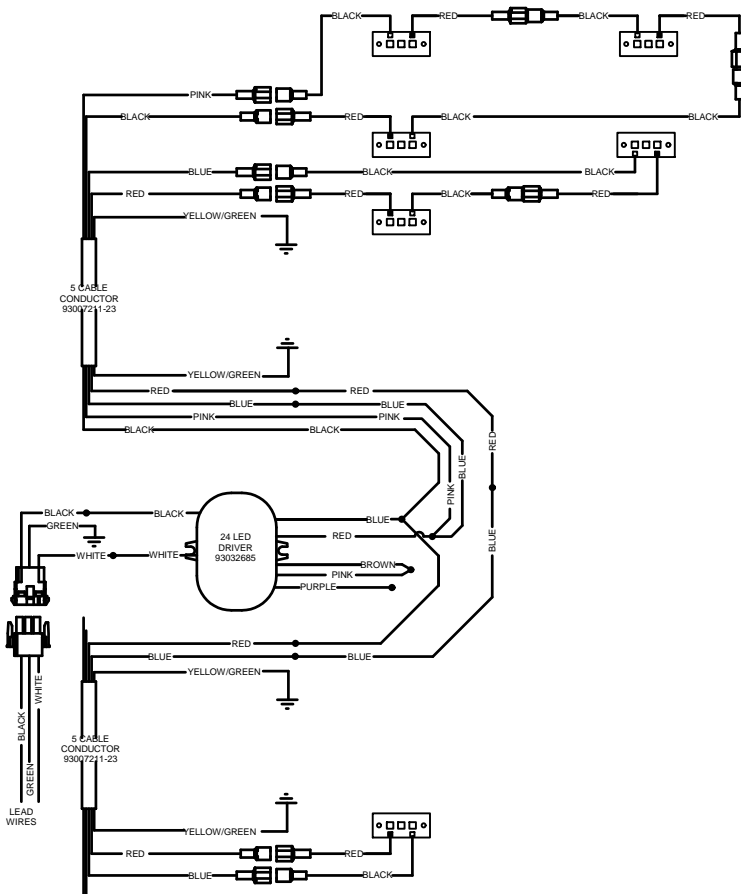

**18 LED
WIRING DIAGM**

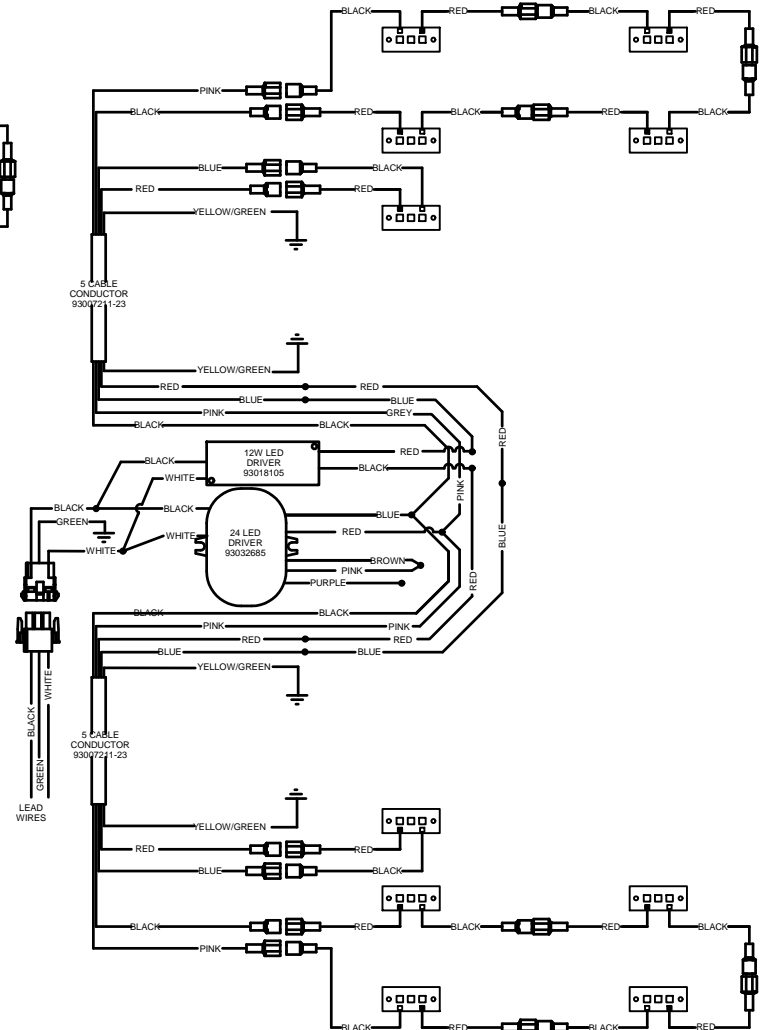

**30 LED
WIRING DIAGM**