

32LED Optical Assembly Retrofit Kit Installation Guide

Fixture: SP1 - Spectra™ Large Scale



WARNING: Fixtures must be grounded in accordance with local codes or the National Electrical Code. Failure to do so may result in serious personal injury.

MAINTENANCE: A regularly scheduled maintenance program should be established to retain optimum light output and reduce heat retention. Dusting with a soft, clean, dry cloth is normally sufficient for the optics.

CAUTION: All wiring must be done by a qualified electrician. KEEP THIS SHEET FOR FUTURE REFERENCE.

PACKAGE CONTENTS:

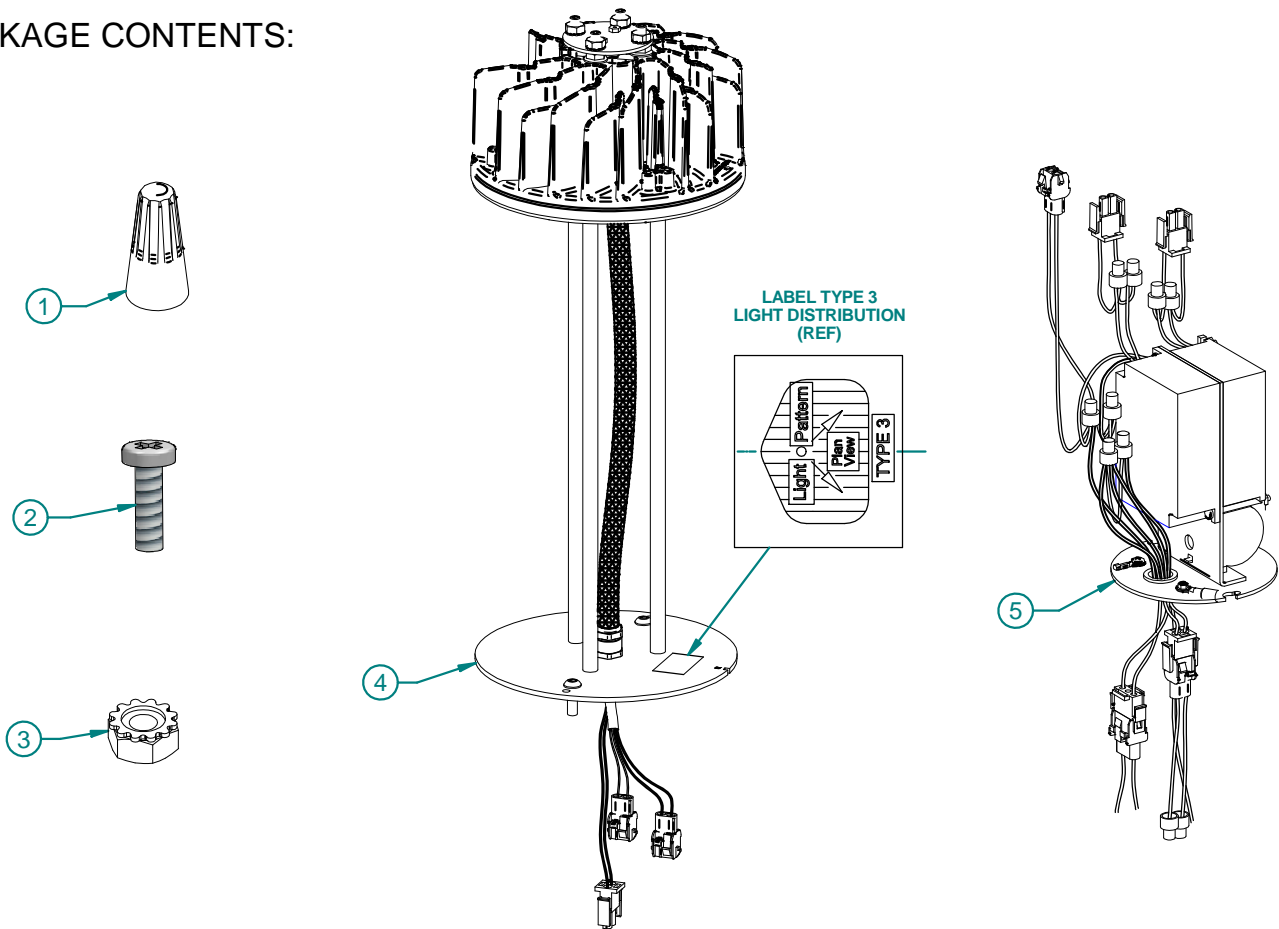

7	1	88033	CABLE TIE 4in HEAT STABILIZED	(NOT SHOWN)
6	1	A96103/A96194/A96195	SP1 INSTALLATION INSTRUCTIONS	SEE PAGE 3
5	1	DRIVER	DRIVER ASS'Y	
4	1	LED	LED OPTICAL ASS'Y	
3	2	A84203	NUT 1/4-20 HEX KEP	
2	2	A84023	SCR-8-32 X 1/2 PHH PHMS SS	
1	5	88481	WIRE NUT (HIGH TEMP)	
ITEM #	QTY	PART #	DESCRIPTION	NOTES

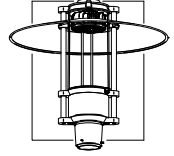

32LED Optical Assembly Retrofit Kit Installation Guide

Fixture: SP1 - Spectra™ Large Scale

REMOVE EXISTING LAMP/BALLAST COMPONENTS:

A. FIXTURE REMOVAL

- !** 1. TURN OFF ALL POWER TO THE UNIT AND TAKE PROPER SAFETY PRECAUTIONS.
- 2. LOOSEN (2) SOCKET HEAD BOLTS (ITEM 8) UNDERNEATH CAST FITTER (ITEM 9).
- 3. LIFT FIXTURE UP AND DISCONNECT WIRE LEAD BETWEEN BALLAST (ITEM 10) AND LAMP (ITEM 13).
- 4. REMOVE FIXTURE ASS'Y FROM CAST FITTER (ITEM 9) AND SET ASIDE.

B. REFLECTOR CONE REMOVAL

- 1. LOOSEN 2X 1/4-20 SCREWS (ITEM 1) AND REMOVE CAP ASS'Y (ITEM 2).
- 2. LOOSEN 1/4-20 CENTER SCREW (ITEM 4) AND REMOVE REFLECTOR CONE (ITEM 5).
- 3. DISCARD THE ITEMS.

C. LAMP ASSEMBLY REMOVAL

- 1. REMOVE EXISTING LAMP ASS'Y (ITEM 13) AND ALL ASSOCIATED HARDWARE (ITEM 12) FROM TOP AND/OR UNDERNEATH CAST HOUSING (ITEM 6). (APPLICATIONS VARY).
- 2. REMOVE GASKET (ITEM 3) IF NEEDED.
- 3. PULL LAMP ASS'Y (ITEM 13) OUT AND DISCARD.

D. BALLAST ASSEMBLY REMOVAL

- 1. LOOSEN 2X 8-32 SCREWS (ITEM 7) AND LIFT BALLAST ASSEMBLY (ITEM 10) UP.
- 2. DISCONNECT INCOMING WIRE LEADS AND REMOVE BALLAST ASSEMBLY.

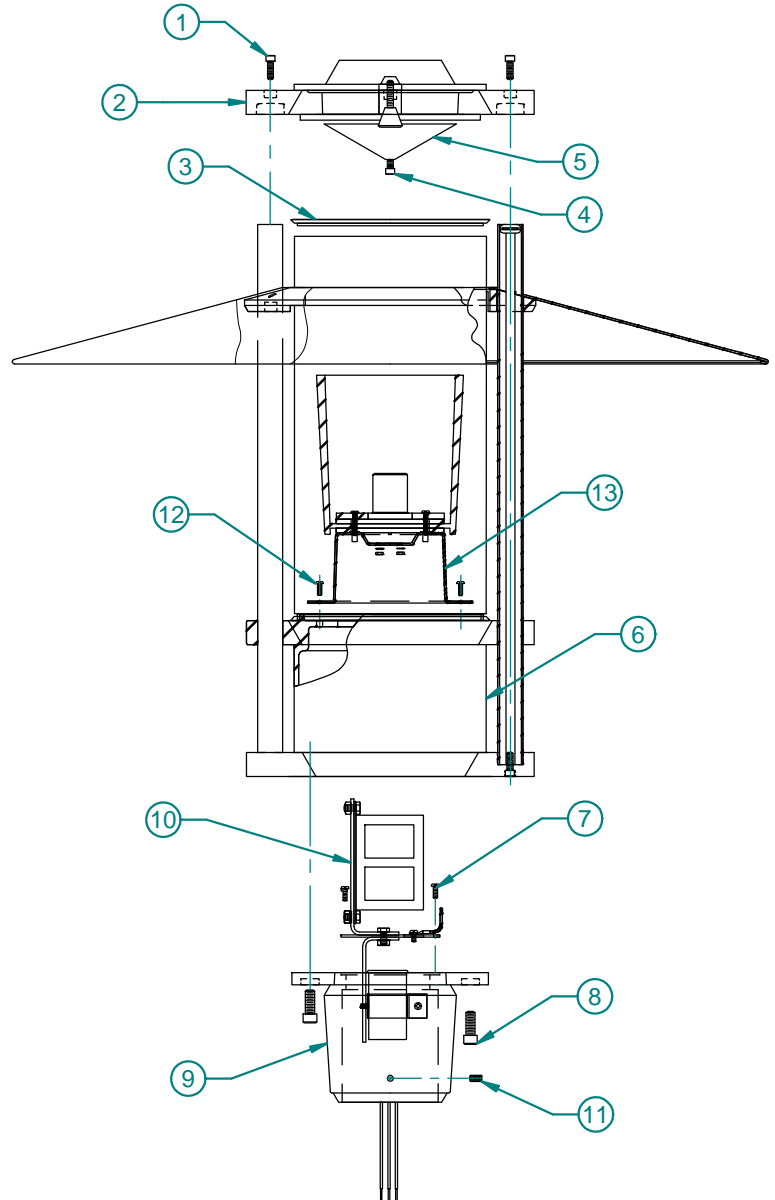

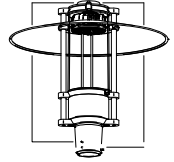

32LED Optical Assembly Retrofit Kit Installation Guide

Fixture: SP1 - Spectra™ Large Scale

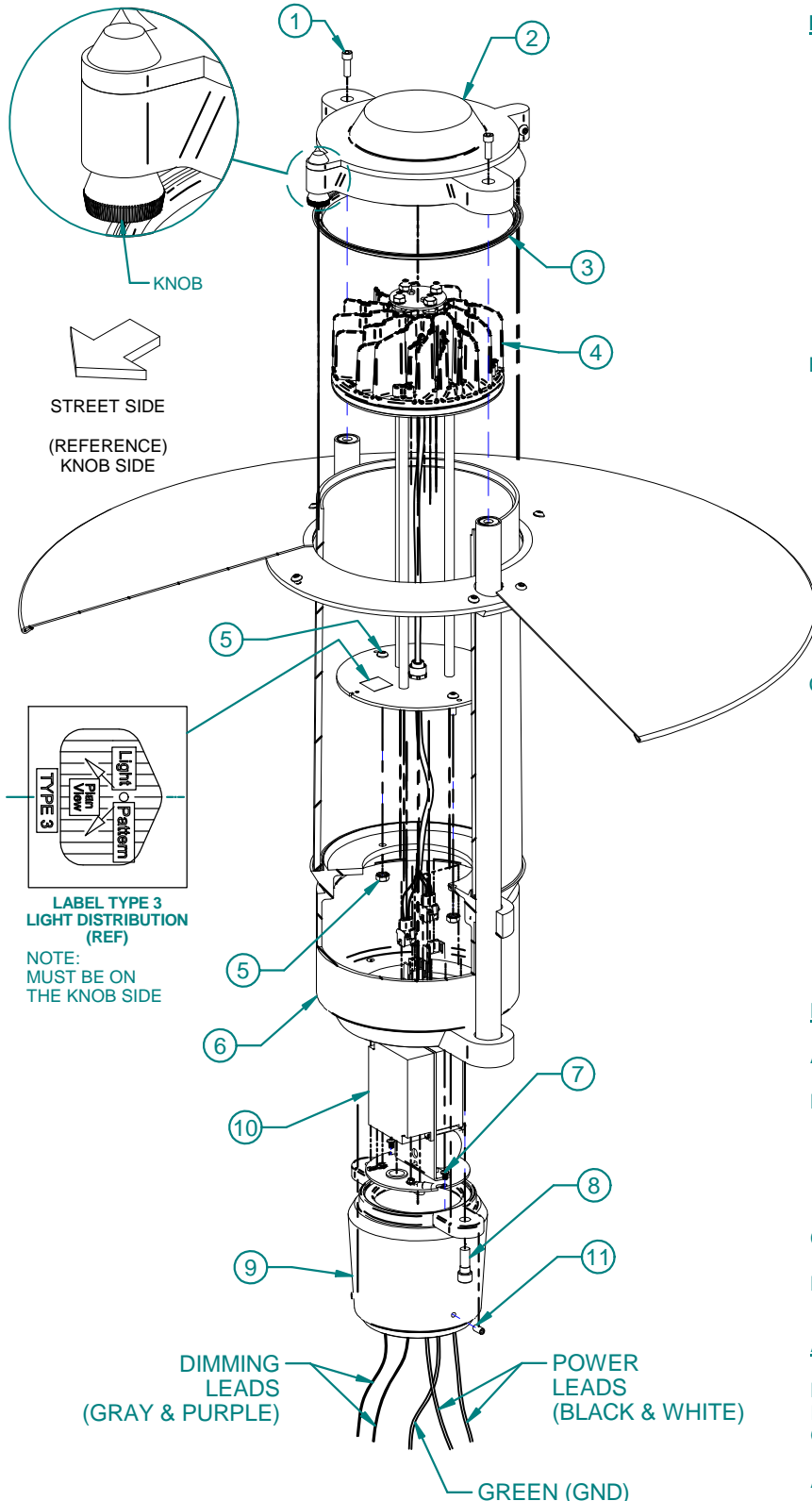

INSTALL LED LIGHT ENGINE/DRIVER ASSEMBLY:

A. LED OPTICAL ASSEMBLY INSTALLATION

1. CAREFULLY DROP IN THE OPTICAL ASS'Y (ITEM 4) INSIDE THE LENS. DEPENDS ON THE APPLICATION, USE EITHER 2X 8-32 OR 2X 1/4-20 SCREWS & NUTS (ITEM 5) TO SECURE THE OPTICAL ASS'Y PLATE.
2. SECURE OPTICAL ASS'Y (ITEM 4) TO CAST HOUSING (ITEM 6) AS SHOWN.
3. REINSTALL GASKET (ITEM 3) AND CAST CAP ASS'Y (ITEM 2).
4. SECURE FIXTURE ASS'Y WITH 2X 1/4-20 SCREWS (ITEM 1).

B. DRIVER ASSEMBLY INSTALLATION

1. MAKE WIRE CONNECTIONS FROM DRIVER ASS'Y (ITEM 10) TO INCOMING SUPPLY.

NOTE:

- a) ASSEMBLY MUST BE GROUNDED TO THE INCOMING EQUIPMENT GROUND SUPPLY.
- b) IF NO DIMMING IS REQUIRED, CAP OFF THE DIMMING LEADS SEPERATELY.

2. SECURE DRIVER PLATE TO CAST FITTER (ITEM 9) WITH 2 X 8-32 SCREWS (ITEM 7).

C. FIXTURE INSTALLATION

1. MAKE WIRE CONNECTIONS BETWEEN DRIVER ASS'Y (ITEM 10) AND OPTICAL ASS'Y (ITEM 4).
2. PLACE FIXTURE OVER CAST FITTER (ITEM 9) AND SECURE WITH 2 SOCKET HEAD BOLTS (ITEM 8).
3. LOOSEN 3 SET SCREWS (ITEM 11) AND ROTATE FIXTURE TO THE DESIRE POSITION WITH CUTOUT NOTCH "R" LINE UP TO THE STREET.
4. SECURE THE 3 SET SCREWS (ITEM 11), TURN ON POWER AND CHECK FOR OPERATION.
5. **INSTALLATION COMPLETE.**

DRIVER SERVICING:

A. SEE FIXTURE REMOVAL STEPS (A1-4, PG 2).

B. DRIVER REMOVAL

1. LOOSEN 2X 8-32 SCREWS (ITEM 7) AND LIFT DRIVER ASSEMBLY UP.
2. DISCONNECT INCOMING WIRE LEADS AND REMOVE DRIVER ASSEMBLY.

C. SERVICE DRIVERS OR REPLACE DRIVERS.

D. SEE FIXTURE INSTALLATION STEPS (C1-5, PG 3).

ADDITIONAL INSTALLATION INSTRUCTIONS:

MAY REQUIRE ONE OF THE FOLLOWING INSTRUCTIONS FOR DIFFERENT MOUNTING OPTIONS:

- A96193: SP1/SP2 - AWM1/AWM2
- A96194: SP1/SP2 - SAP/TAP
- A96195: SP1/SP2 - STD MNT

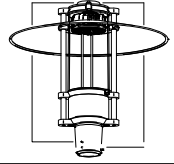

32LED Optical Assembly Retrofit Kit Installation Guide

Fixture: SP1 - Spectra™ Large Scale

WIRING DIAGRAM

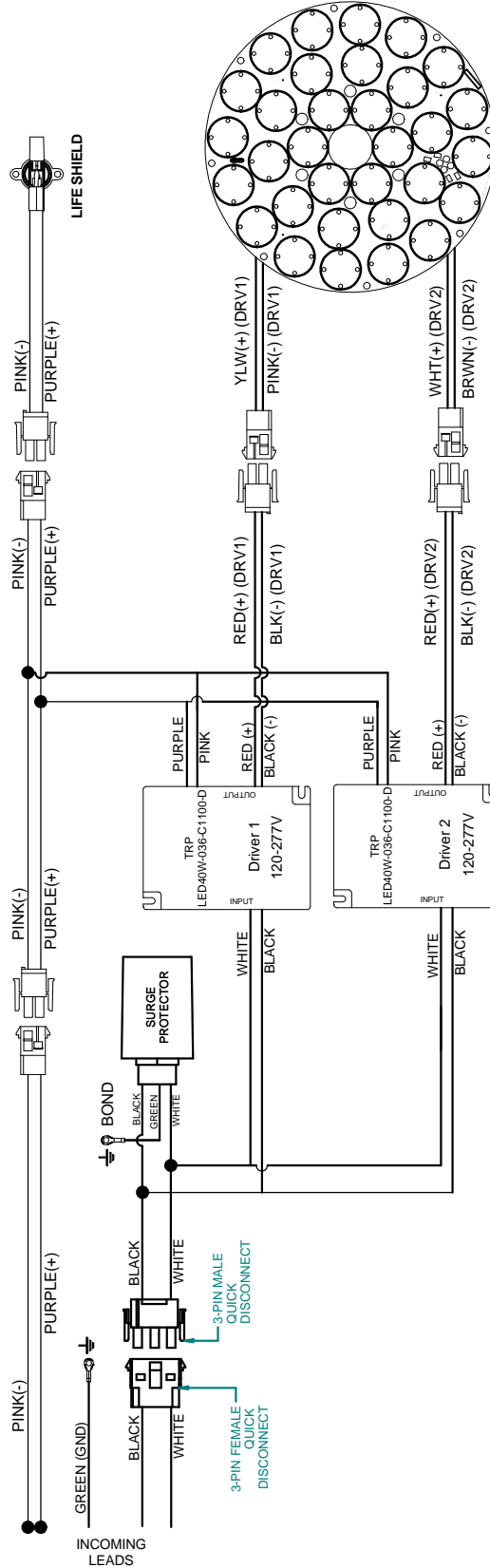

INSTALLATION INSTRUCTIONS

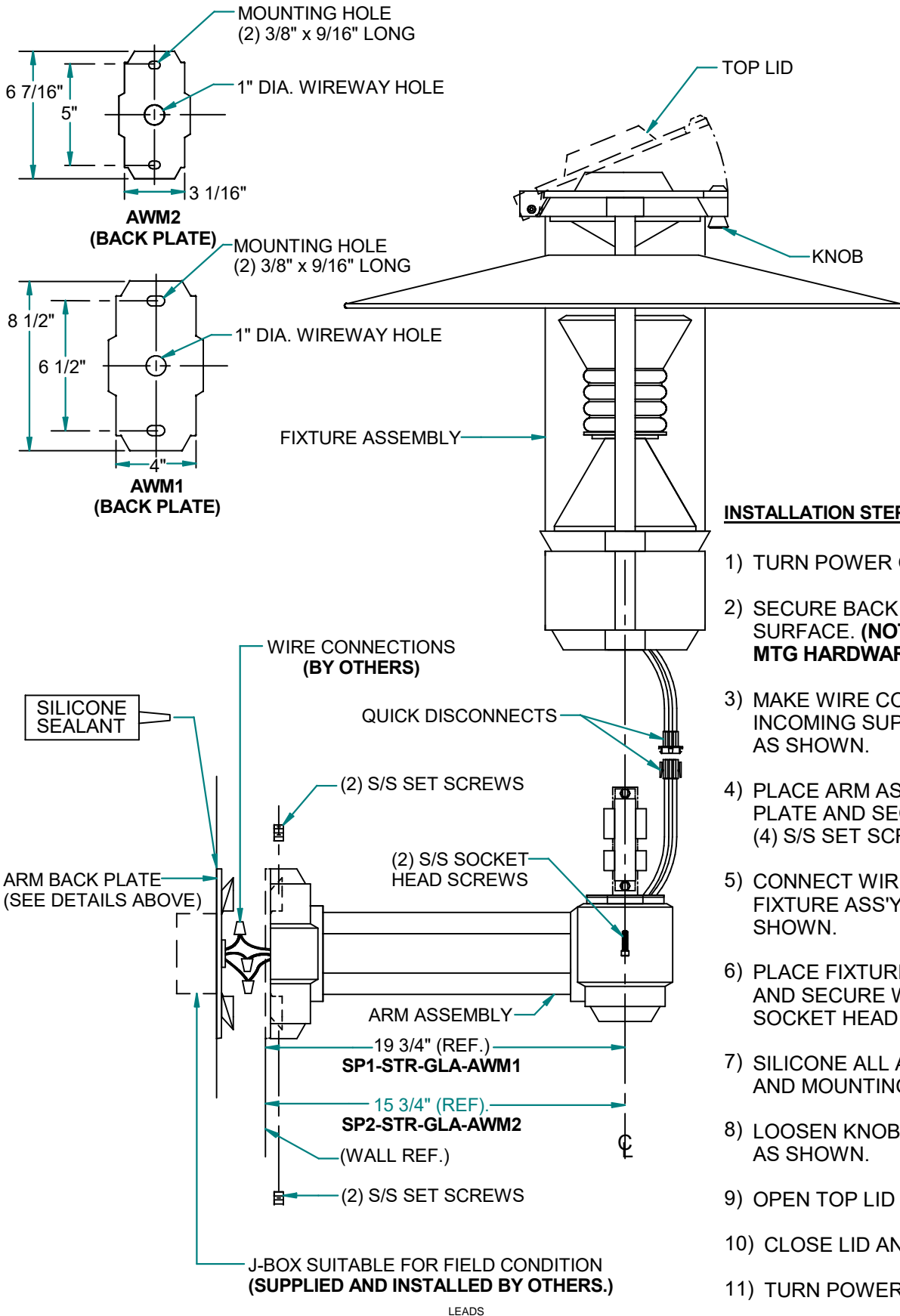

INSTALLATION STEPS:

- 1) TURN POWER OFF
- 2) SECURE BACK PLATE TO MTG SURFACE. **(NOT FOR J-BOX MOUNTING. MTG HARDWARE BY OTHERS).**
- 3) MAKE WIRE CONNECTIONS FROM INCOMING SUPPLY TO ARM ASS'Y AS SHOWN.
- 4) PLACE ARM ASSEMBLY OVER BACK PLATE AND SECURE FIRMLY WITH (4) S/S SET SCREWS.
- 5) CONNECT WIRE HARNESS FROM FIXTURE ASS'Y TO ARM ASS'Y AS SHOWN.
- 6) PLACE FIXTURE ASS'Y ONTO ARM ASS'Y AND SECURE WITH (2) S/S 1/4-20 x 3/4" SOCKET HEAD SCREWS.
- 7) SILICONE ALL AROUND BACK PLATE AND MOUNTING SURFACE AS SHOWN.
- 8) LOOSEN KNOB FROM TOP LID AS SHOWN.
- 9) OPEN TOP LID AND INSTALL LAMP.
- 10) CLOSE LID AND SECURE.
- 11) TURN POWER ON.

LEADS

INSTALLATION INSTRUCTIONS

CATALOG NUMBER
SP1-IND

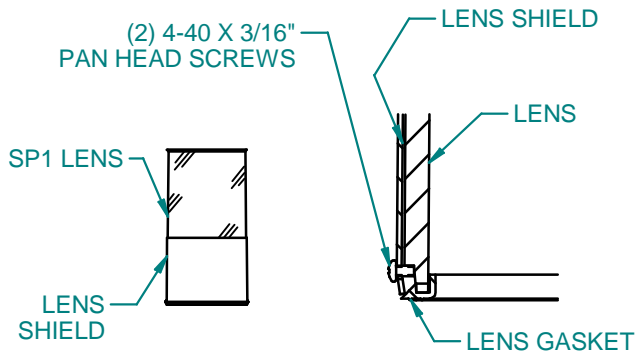
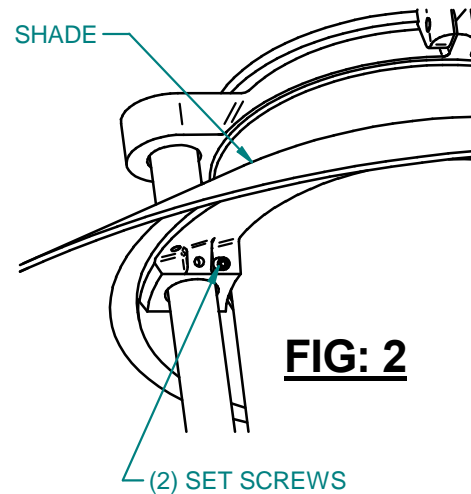
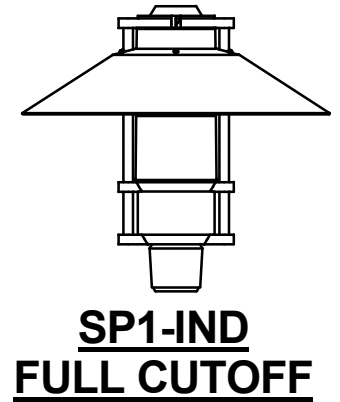
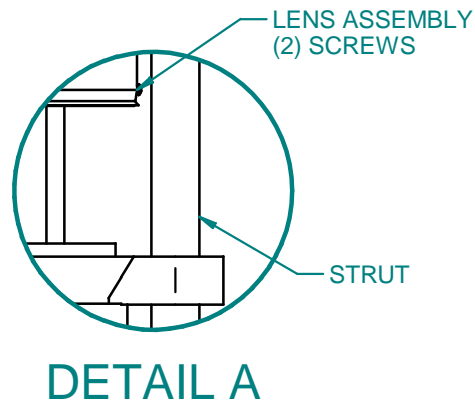
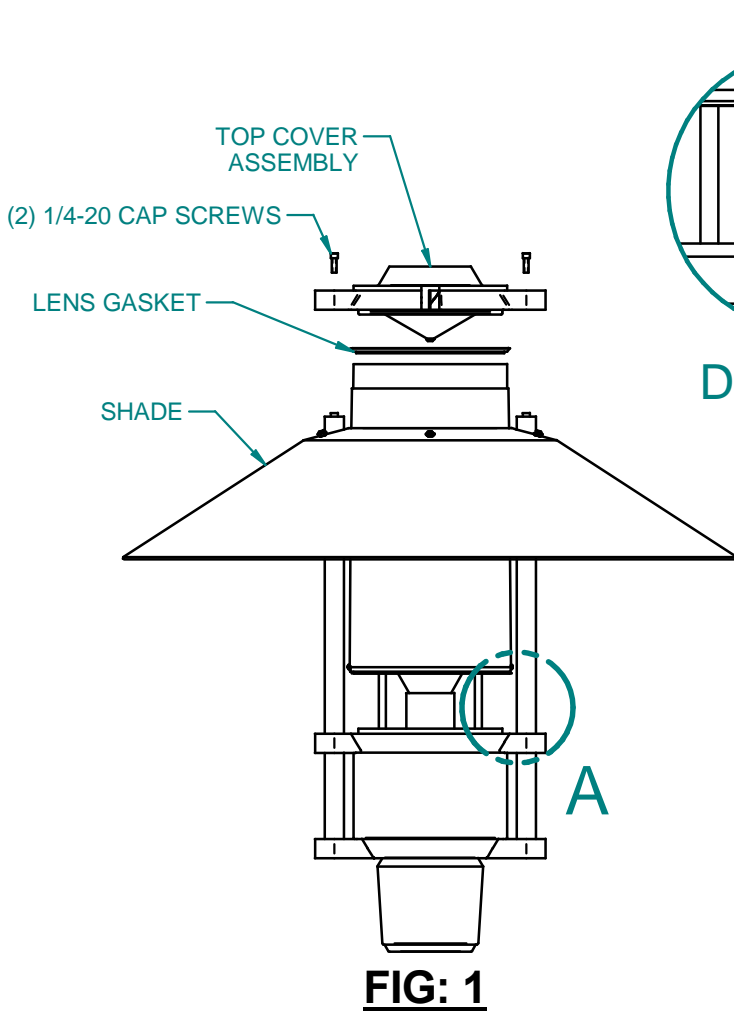

LENS ASSY

FIG: 3

INSTALLATION STEPS:

1. TURN OFF POWER.
2. REMOVE (2) 1/4-20 CAP SCREWS FROM TOP COVER ASSEMBLY (SEE FIG. 1).
3. LOOSEN SET SCREWS FROM UNDERSIDE OF SHADE ASSEMBLY (SEE FIG. 2).
4. REMOVE EXISTING LENS, LENS GASKETS AND SHADE ASSEMBLY.
5. ASSEMBLY SHIELDED LENS: SLIDE LENS SHIELD OVER LENS. SHIELD AND BOTTOM OF LENS ARE EVEN WITH GASKET BETWEEN (SEE FIG. 3).
6. SECURE LENS SHIELD ASSEMBLY WITH (2) 4-40 SCREWS (SEE FIG. 3).
7. INSTALL SHIELDED LENS ASSEMBLY AND ALIGN SCREWS BEHIND STRUTS.
8. INSTALL FULL CUTOFF SHADE ASSEMBLY OVER STRUTS (SEE DETAIL A).
9. REPLACE LENS GASKET OVER TOP OF LENS
10. INSTALL TOP COVER OVER LENS AND STRUTS AND SECURE WITH (2) 1/4-20 CAP SCREWS.
11. SECURE FULL CUTOFF SHADE ASSEMBLY AGAINST TOP COVER ASSEMBLY
12. INSTALLATION COMPLETE.