

OPERATION

Automatic Tests

The unit will automatically initiate a self-test/self-diagnostic cycle based on the following table:

Testing Period	Duration of Test
Once a month	1 minute
Once every 6 months	Alternating: 30 minutes or 60 minutes

Manual Tests

Using the unit test switch, users can initiate different duration test cycles based on the following table:

Initiating Action	Test Cycle
Press test switch once	1 minute
Press test switch twice	90 minutes

Pressing the test switch any time after a 90 minute test cycle has begun cancels the remainder of the 90 minute test and returns the unit to normal operation.

LED Status Indicator:

A green/red LED is provided on the control pane of all models equipped with the Spectron option.

Green Operating Status LED:

The green Operating Status LED serves as both an AC power and self-test indicator. During normal operation, the green Operating Status LED will be illuminated, indicating the presence of AC power. During all automatic or manual self-test cycles, the green Operating Status LED will blink "twice" per second for the 30 / 60 / 90 minute test.

Red Service Alert LED:

Under normal operating conditions, the red Service Alert LED indicator will remain off. If the Spectron controller detects a malfunction, the red Service Alert LED will blink in the pattern listed on the label around the test button.

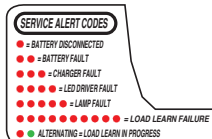

93052054

Temperature Codes and Maximum Temperature Ratings

Operating Temperature in C°			
Ambient C°	Class1 DIV. 2 A,B,C,D	CLASS II DIV. 1 E,F,G	Supply Wire Temp. C ° Min.
40	T6	T6	75
50	T5	T6	75

Service / Maintenance

Maintenance

This emergency lighting unit should be tested and maintained in accordance with National Electrical Code and NFPA 101 Life Safety Code requirements. It is recommended that emergency light fixtures be tested for 30 seconds once a month and for 90 minutes once a year.

Taking A Unit Out of Service

If a unit is to be deliberately taken out of service for an extended period, the battery lead connector should be disconnected from the charger circuit board and insulated so that the battery will go into storage in a fully charged condition.

Replacing the Battery:

1. De-energize the AC power.
2. Remove the front housing cover.
3. Disengage the battery and heater (if provided) harness from the charger PCB harness.
4. Disconnect the battery strap and remove battery pack.
5. Replace with new battery (see unit model label or battery label for correct p/n) and repeat steps above in reverse.

Replacing LED Lamps

The LED lamp heads are field replaceable. Please see the Dual-Lite website for further assistance.

Troubleshooting

Emergency circuit does not work

- Batteries are shipped uncharged, please charge for 24 hours before testing.
- Make sure the switch pcb and the button/light pipe is correctly seated and aligned.
- Check wiring connections.



RECYCLING INFORMATION

All steel, aluminum and thermoplastic parts are recyclable.
NOTICE: Emergency units contain rechargeable batteries which must be recycled or disposed of properly.

93049060
93049063
93055894
93055812
93055892
93055893
93055895
93055897
93055896
93061887

93066456_A 10/3/15



DYN Series

High-Capacity LED Industrial Emergency Lighting Unit
Wet Location, NEMA 4X & Food Processing
Standard, Remote Capacity and Spectron Equipped Models
Installation, Operation, and Service Instructions

Class1, Division 2 Groups A,B,C,D	Class 1, Zone2 Groups IIA, IIB, IIB+H ₂ , IIC
Class2, Division 1 Groups E,F,G	

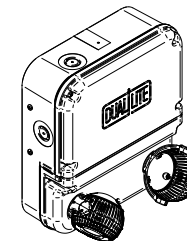

IMPORTANT SAFEGUARDS

When using electrical equipment, basic safety precautions should always be followed including the following.

READ AND FOLLOW ALL SAFETY INSTRUCTIONS

1. Do not let power supply cords touch hot surfaces.
2. Do not mount near gas or electric heaters.
3. Equipment should be mounted in locations and at heights where it will not readily be subject to tampering by unauthorized personnel.
4. The use of accessory equipment not authorized by the manufacturer may cause an unsafe condition.
5. Do not use this equipment for other than its intended purpose.
6. Servicing of this equipment should be performed by qualified service personnel.
7. Test cycling: the Life Safety Code (NFPA 101) requires testing of emergency lighting units once a month for a minimum of 30 seconds, and once a year for a minimum of 90 minutes.

INSTALLER:

- SEE UNIT LABEL FOR ADDITIONAL MODEL SPECIFICATIONS
- SAVE THESE INSTRUCTIONS FOR USE BY OWNER/OCCUPANT

WARNING- This product contains chemicals known to the State of California to cause cancer, birth defects, and/or other reproductive harm. Thoroughly wash hands after installing, cleaning, or otherwise touching this product.

INSTALLATION

This Industrial Unit is designed to be mounted on a wall, ceiling or pole (optional). Provide standard units with a single unswitched power supply from a 120 - 277VAC branch circuit used for normal lighting in the areas to be protected. For Spectron self-testing/self diagnostic units, provide unit with a 120/277VAC branch circuit.

The DYN Industrial unit is equipped with intelligent wiring. Connect the black wire from unit to the building hot wire (120 or 277VAC) and the white wire to the building com wire. (Exceptions: All Non-Spectron models should be connected to 120, 240 or 277VAC supplies only.)

Wall, Ceiling or Pole Mounting

1. The DYN mounting plate can be mounted directly to a wall, ceiling or pole (using appropriate hardware). If "J-box" mounted and the plastic housing back K.O. is removed the unit is not considered water proof.
2. Once mounting plate is secured, you can hang the DYN Industrial Unit and add security screws (qty 4).
3. If the DYN unit is mounted to the ceiling the 4 security screws are to be added to keep the unit secure to the mounting plate.
4. If "J-box" mounted & wired thru box, ground DYN mounting plate with green ground wire & green hex head screw (provided).
5. For all units wired using conduit, use 1 of the 3 conduit (K.O.) mounting locations.
6. Only use UL Listed water tight conduit fittings that meet the requirements of the UL 514B Standard for Conduit Tubing and Cable Fittings when using (K.O.'s see note 5).
7. Connect wire from the unit to the building leads and secure with wire nuts.
8. For remote capable DYN models, cut ORANGE wire connector from orange remote leads and strip 1/2 inch for both lead ends. Observe proper polarity when connecting remote leads to remote fixtures. Pos. (+) to red remote fixture lead and Neg. (-) to black remote fixture lead.
9. Connect battery pack harness to PCB charger harness.
10. For pole mounting used additional #8-32 x 1/4 long screws (qty 2) and both toothed mounting brackets as shown. Banding straps are not provided due to varying pole and column dimensions.

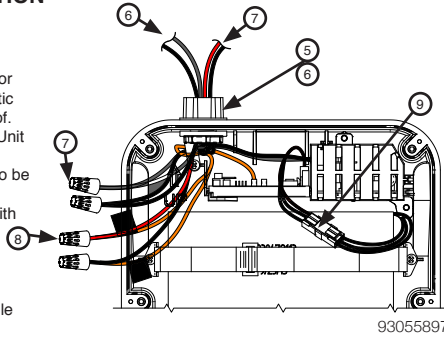

93055897

Pole Mounting

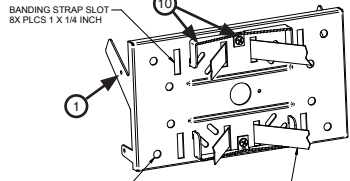

93061887

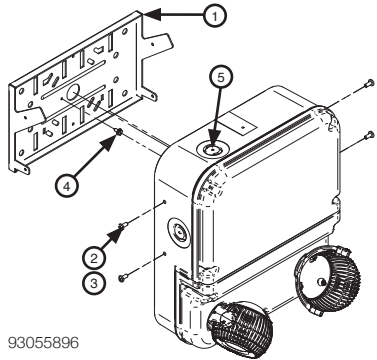

93055896

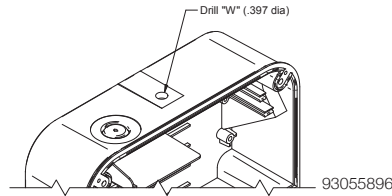

93055896

UNIT CAN BE HUNG BY THREADED ROD
 3/8 THREADED ROD IS RECOMMENDED
 USE APPROPRIATE HARDWARE TO SUPPORT THIS
 UNIT WHEN THREADED ROD MOUNTED. LOCK-TIGHT
 BLUE IS RECOMMENDED FOR ALL MOUNTING HARDWARE.

Lamp Head Adjustment

1. Loosen the three captive screws on the Food Processing clear cover.
2. Remove cover. (all models without clear cover skip step 1 & 2)
3. Rotate lamp heads to desired position.
4. Loosen set screws 2 per head and adjust axially on stem.
5. Lock set screws once desired position is set (hex wrench provided).
6. Reverse steps 2 & 1 (if required).

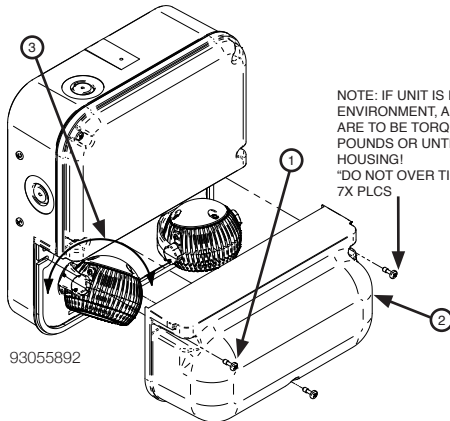

93055892

NOTE: IF UNIT IS IN A WET LOCATION ENVIRONMENT, ALL COVER SCREWS ARE TO BE TORQUED TO 5-6 INCH POUNDS OR UNTIL COVER SEATS WITH HOUSING!
 "DO NOT OVER TIGHTEN SCREWS" 7X PLCS

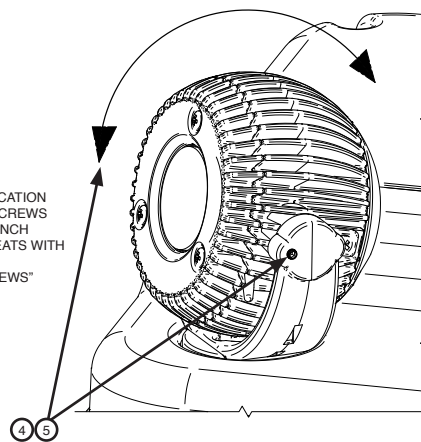

93055893

DYN Wiring Diagram

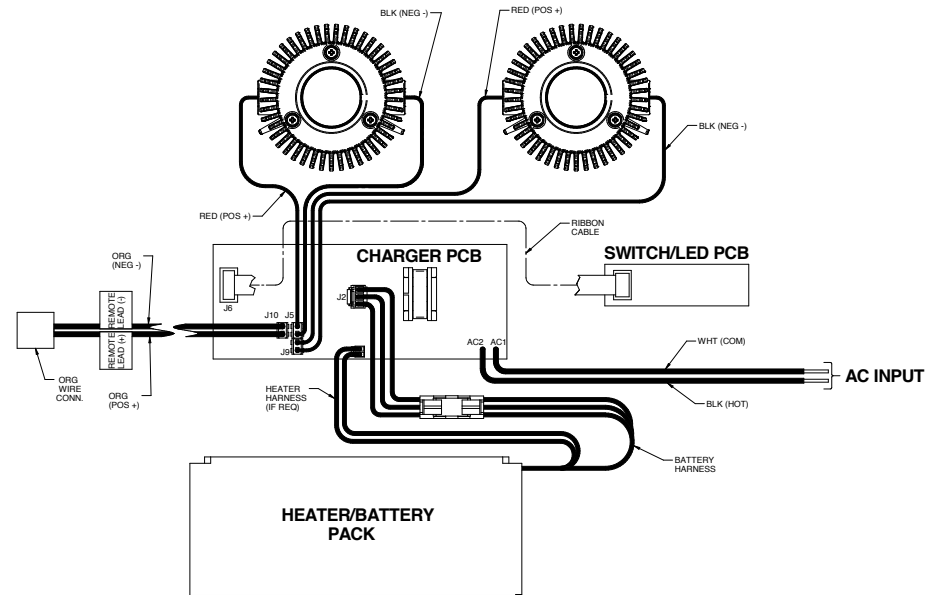

93055812

OPERATION

Once remote capacity base models DYN12 or DYN12I have been installed press and hold the test button for more than 5 seconds to initiate the "LOAD LEARN" process.

"AC ON" LED is illuminated when AC power is present.

NOTE: All models are supplied with an AC Lockout circuit, which prevents the emergency lights from illuminating when the battery is connected and no AC power is present.

NOTE: All models are supplied with Low Voltage Disconnect circuit, which prevents damage to the battery from deep discharge during prolonged emergency operation.

NOTE: Batteries are often shipped in a discharged state – this is normal. The battery will require charging. Allow 24 hours of charging before testing the unit.

Models without SPECTRON® Self-Diagnostic

Models without Spectron® self diagnostic electronics system provide:

- Visual indication of AC power status
- Visual indication of any unit malfunctions include –**
 - Battery Disconnected
 - Charger Fault

Models with SPECTRON® Self-Testing/Self-Diagnostic Circuitry

Models equipped with the Spectron® self-testing/self-diagnostic electronics system provide:

- Visual indication of AC power status
- Visual indication on self-diagnostic status and results
- Visual indication of any unit malfunctions include –**
 - Battery Disconnected
 - Battery Fault
 - Charger Fault
 - LED Driver Fault
 - Lamp Fault
 - Load Learn Failure

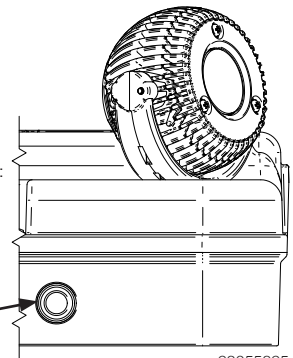

93055895

Spectron equipped units also include:

Brownout protection: Unit will automatically transfer to emergency operation upon detection of low AC power (approximately 80% of nominal line.)

Time Delay Retransfer: upon return of normal AC power, unit will remain in emergency mode for an additional 15 minutes to allow AC power to stabilize.