



KIT - LASER REMOTE TESTER

Laser activated Self-Diagnostics



IMPORTANT SAFEGUARDS

When using electrical equipment, basic safety precautions should always be followed including the following.

READ AND FOLLOW ALL SAFETY INSTRUCTIONS

1. Do not let power supply cords touch hot surfaces.
2. Do not mount near gas or electric heaters.
3. Equipment should be mounted in locations and at heights where it will not readily be subject to tampering by unauthorized personnel.
4. The use of accessory equipment not authorized by the manufacturer may cause an unsafe condition.
5. Do not use this equipment for other than its intended purpose.
6. Servicing of this equipment should be performed by qualified service personnel.
7. Test cycling: the Life Safety Code (NFPA 101) requires testing of emergency lighting units once a month for a minimum of 30 seconds, and once a year for a minimum of 90 minutes.

INSTALLER:

- SEE UNIT LABEL FOR ADDITIONAL MODEL SPECIFICATIONS
- SAVE THESE INSTRUCTIONS FOR USE BY OWNER/OCCUPANT

WARNING- This product contains chemicals known to the State of California to cause cancer, birth defects, and/or other reproductive harm. Thoroughly wash hands after installing, cleaning, or otherwise touching this product.

WARNING: Laser pointer is not a toy!

Avoid direct eye exposure, as this product emits laser radiation.

Follow laser manufacturer's operation instructions and safety precautions.

When operating laser, always use safety glasses. Pair supplied with kit.



RECYCLING INFORMATION

All steel, aluminum and thermoplastic parts are recyclable.
 NOTICE: Emergency units contain rechargeable batteries which must be recycled or disposed of properly.

LED Status Indicator:

A green/red LED is provided on the control pane of all models equipped with the Spectron option.

Green Operating Status LED:

The green Operating Status LED serves as both an AC power and self-test indicator. During normal operation, the green Operating Status LED will be illuminated, indicating the presence of AC power. During all automatic or manual self-test cycles, the green Operating Status LED will blink "twice" per second for the 30 / 90 minute test.

Red Service Alert LED:

Under normal operating conditions, the red Service Alert LED indicator will remain off. If the Spectron controller detects a malfunction, the red Service Alert LED will blink in the pattern listed on the label around the test button.

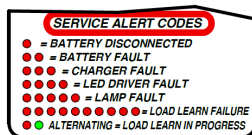

Manual Tests

With the laser pointer, users can initiate different duration test cycles based on the following table, simulating the pressing of the test button.

Initiating Action	Test Cycle
Flash laser sensor once	1 minute
Flash laser sensor twice	90 minutes

Flashing the laser sensor at any time after a 90 minute test cycle has begun cancels the remainder of the 90 minute test and returns the unit to normal operation.

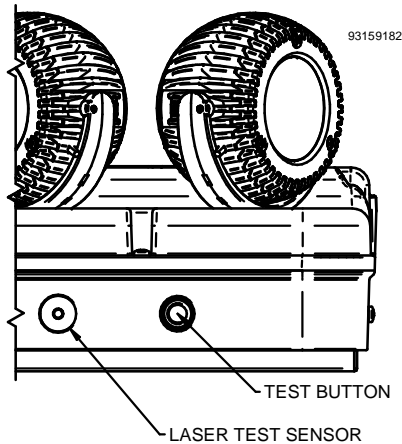

Safety Glasses

Laser Activated Testing

Units are equipped with a laser activated testing feature which allows test initiation with a laser pointer (sold separately).

- For a 1 minute test, aim laser beam onto area shown until the unit's lamp heads turn on and the green LED Status Indicator starts blinking twice every second. The unit will stay in this mode for the complete duration of the test.
- To change from a 1 minute test to a 90 minute test, aim laser onto area shown again until the green LED Status Indicator starts blinking at a slower pace, once every second. The unit will stay in this mode for the complete duration of the test.
- To cancel test cycle, aim laser onto area shown while the 90 minute test is in progress until the unit's lamp heads turn off and LED Status Indicator stops blinking and comes back to a solid green.

NOTE: Maintain a steady beam onto area shown.