



# LES Series Surface Mount Edge-Lit Pendant Mounting Kit Installation Instructions

1.

Connect leads supplied with kit and AC input conductors (use black wire for 120V and red wire for 277V). Connect building ground wire to the green wire connected to the canopy.

2.

Route wires through center of mounting adaptor plate. Affix adaptor plate using electrical box screws(not included).

3.

Using the two #8 screws (supplied with kit), mount upper pendant bracket (supplied with kit) to canopy.

4.

Prepare pendant stem pipe for mounting by installing nuts and locking washers. (For stem length longer than 12", multiple stems need to be connected using supplied couplers.)

5.

Assemble pendant stem pipe to canopy assembly in the sequence shown (including canopy cover plate). Thread stem pipe onto Upper Pendant Bracket. Tighten lower stem pipe nut to lock assembly together. Attach lower pendant bracket on the other side of the stem.

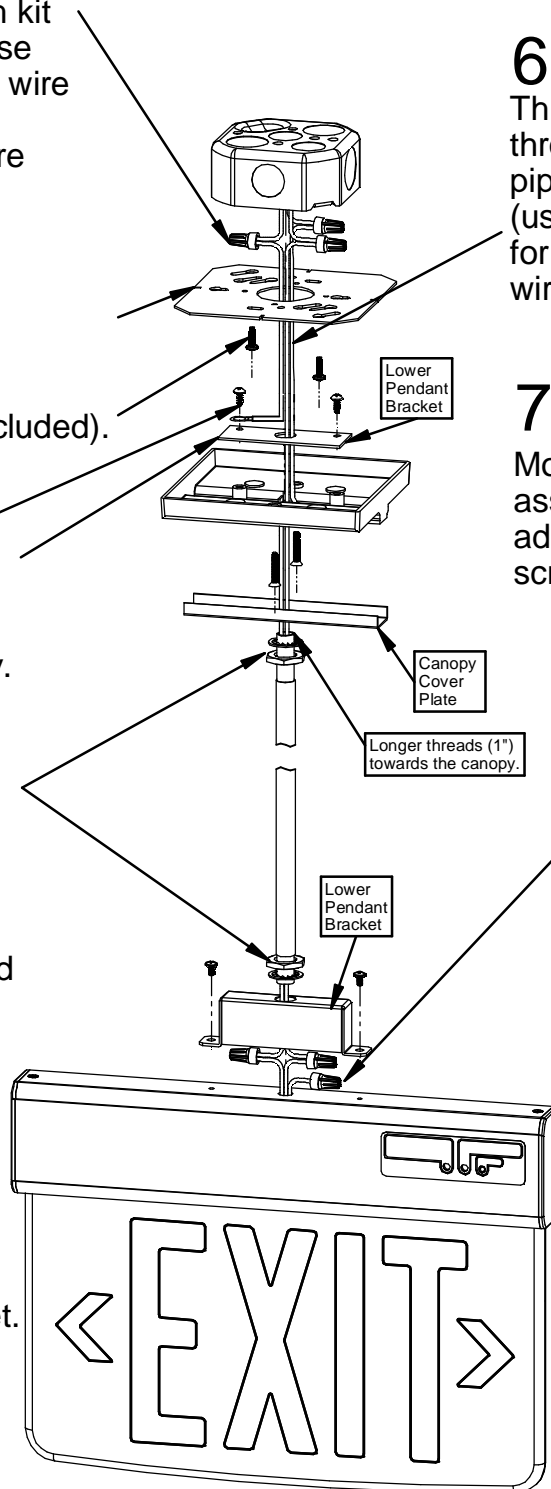

6.

Thread 2 conductor wires through canopy and stem pipe assembly as shown (use black and white wires for 120V, red and white wires for 277V).

7.

Mount canopy/stem pipe assembly to electrical box adaptor plate using captive screws included in the fixture.

8.

Connect the conductor wires, cap off the unused wire (cap off red wire if connecting to 120V input or black wire if connecting to 277V input)

9.

Push all the wires and connectors into Lower Pendant Bracket. (Trim the wires as needed.) Mount lower pendant bracket to exit housing using two #8-32 screws provided. (Make sure wires are not pinched)