

DTS Dimming Bypass Module

INTRODUCTION

OVERVIEW

The DTS is a dimming bypass module used with an inverter or generator in emergency systems. The DTS works by constantly sensing for the presence of utility power. When utility power is no longer sensed (during a power outage), the DTS will bypass any dimming or controls integral to or networked with the fixture. Fixtures that can be dimmed must return to an undimmed (or pre-determined) state with loss of utility power, to meet UL924 requirements.

LUMINAIRE USE

The DTS cannot be used in conjunction with GTD, ATSD or ELL14/40 (Emergency Battery Pack) options. Each luminaire has different restrictions of use, please check individual specification sheets for compatibility. The DTS is available only as a factory-installed option.

EMERGENCY CIRCUITS

While the DTS is UL924 listed, it is not used to transfer power. The transfer of power must happen through a UL1008 module, (such as an AETS – Automatic Emergency Transfer Switch), to meet building code. The DTS is to be used in conjunction with an emergency AC power supply, such as an inverter or generator.

These systems are designed/specified by qualified professionals.

CONNECTIONS FROM FIXTURE TO BUILDING SYSTEM

The following 10 cases are outlined in the included wiring diagram package if further information is needed. The following outlines key connections to perform when installing new fixtures, as well as wiring internal to the fixture.

DTS Dimming Bypass Module

SYSTEM LAYOUT EXAMPLES

EXAMPLE OF BASIC SYSTEM LAYOUT

Below are 3 situations of a system layout using a DTS module

*Specific layouts may vary

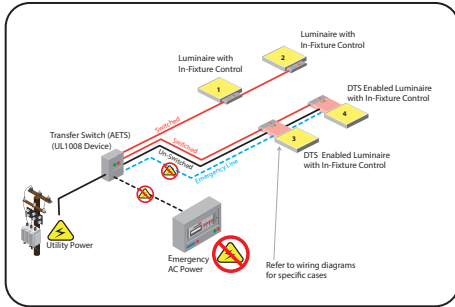

SITUATION 1 (below)
Normal Undimmed Operation

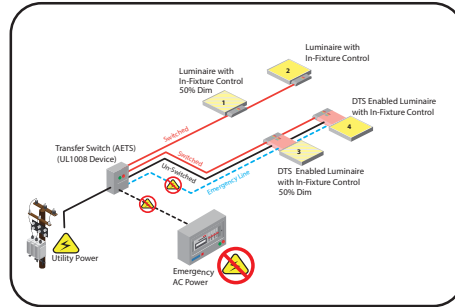

SITUATION 2 (pg. 3)
Dimmed Operation

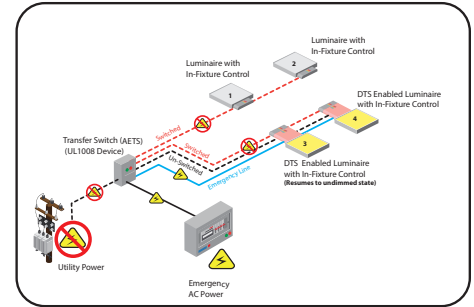

SITUATION 3 (pg. 4)
Emergency Operation

SITUATION 1: NORMAL UNDIMMED OPERATION

- Each luminaire has in-fixture control and is not dimmed
- Luminaires 3 & 4 are also emergency enabled with DTS modules

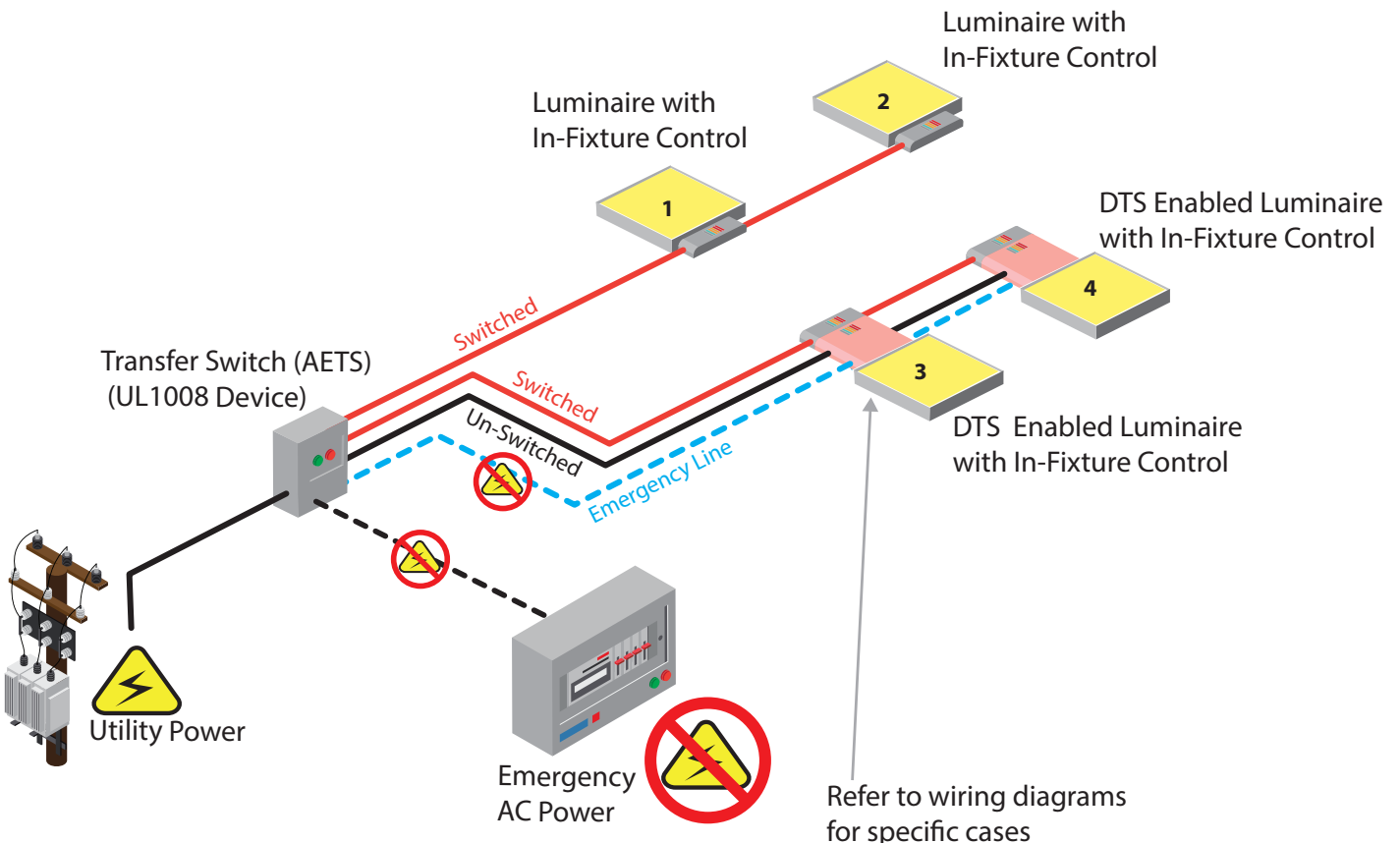

DTS Dimming Bypass Module

SYSTEM LAYOUT EXAMPLES

SITUATION 2: NORMAL UTILITY POWER OPERATION, INDIVIDUAL DIMMING CONTROL

- Luminaires 1 & 3 are in a dimmed state by user choice

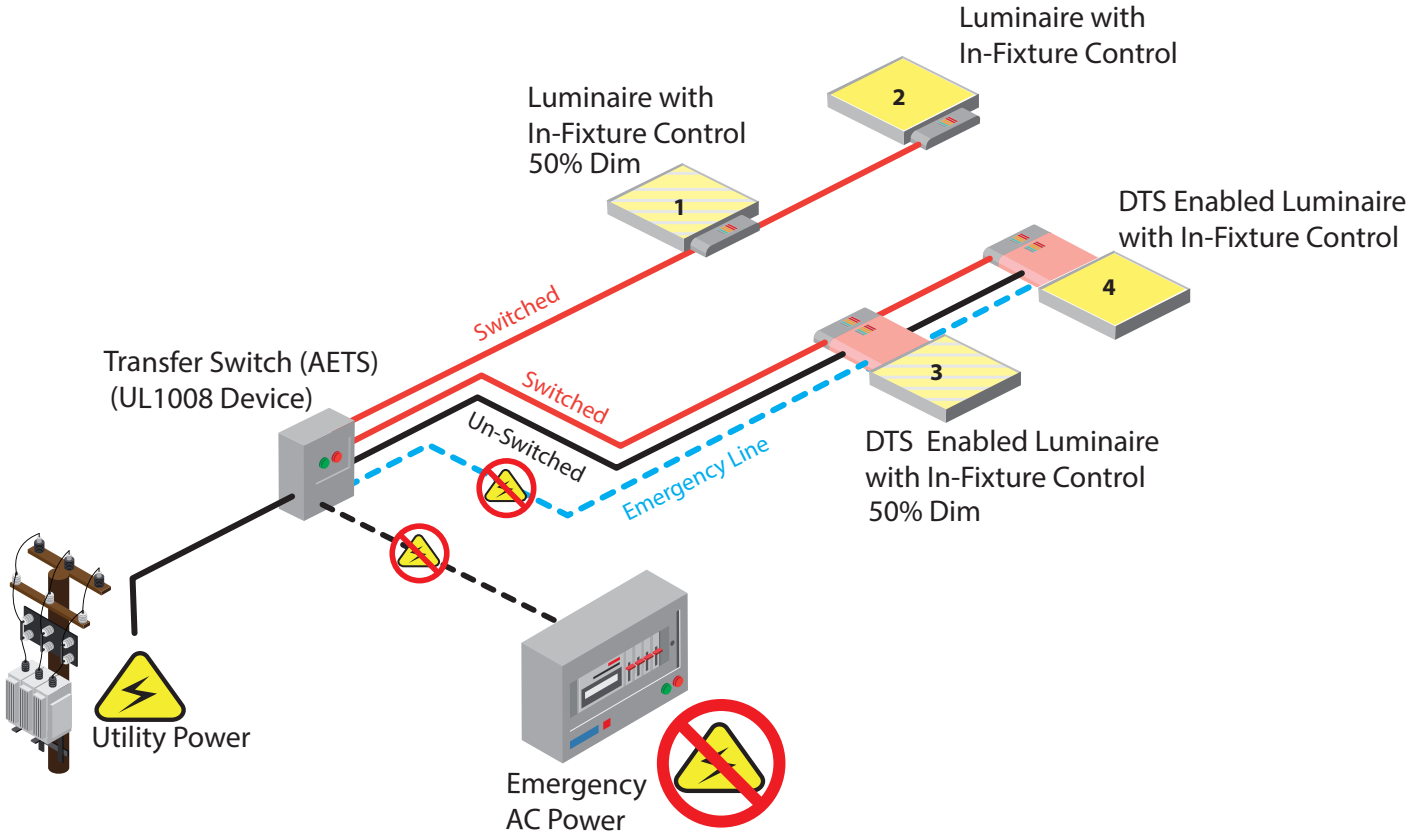

DTS Dimming Bypass Module

SYSTEM LAYOUT EXAMPLES

SITUATION 3: LOSS OF UTILITY POWER

- Transfer switch will transfer power from utility to emergency power source
- Luminaires 1 & 2 lose power
- DTS opens dimming circuits in luminaires 3 & 4 which then resume their undimmed state to meet UL924 requirements

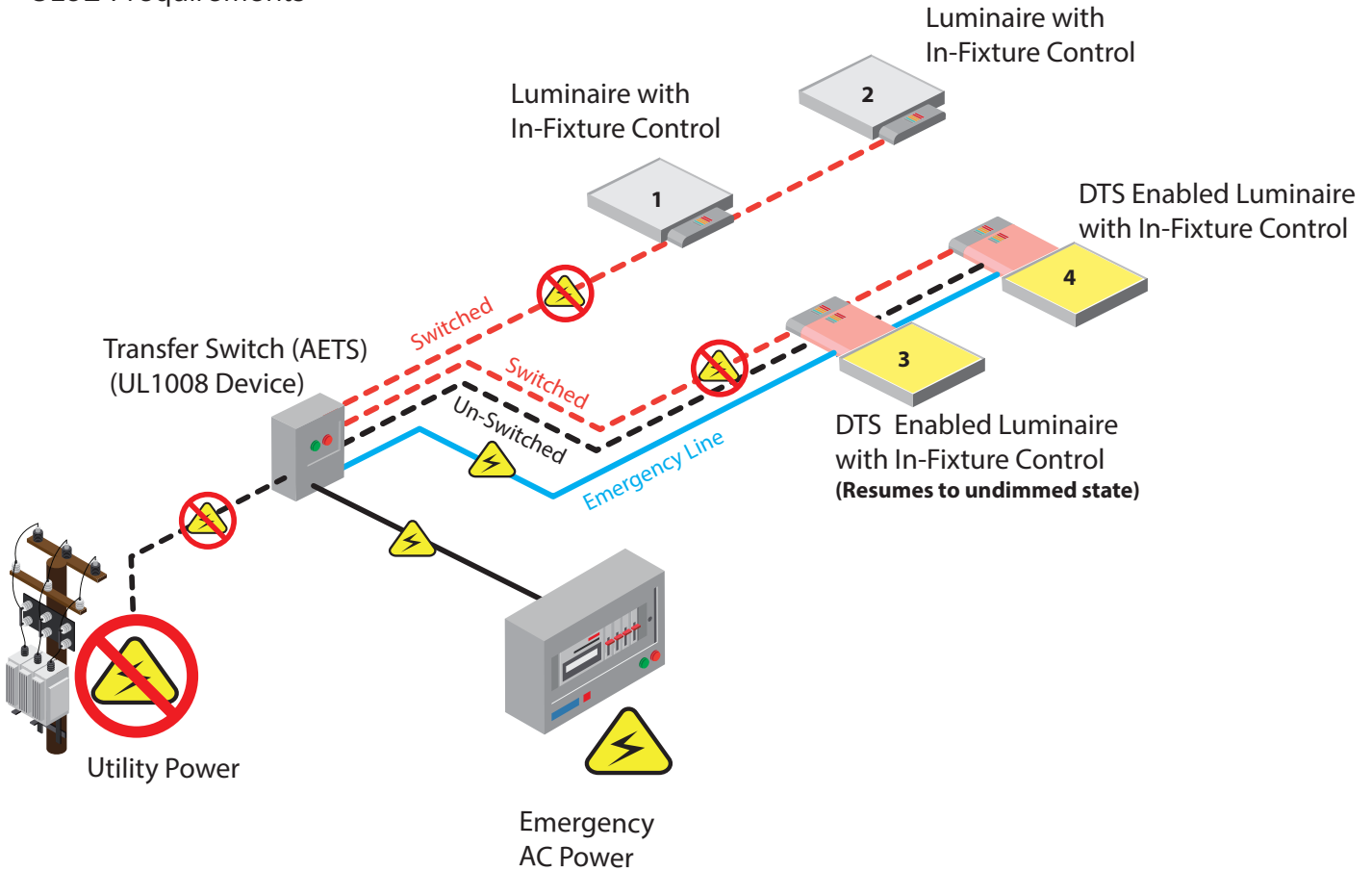

DTS Dimming Bypass Module

WIRING DIAGRAMS

CASE 1: DTS WITH EXTERNAL DIMMING CONTROL

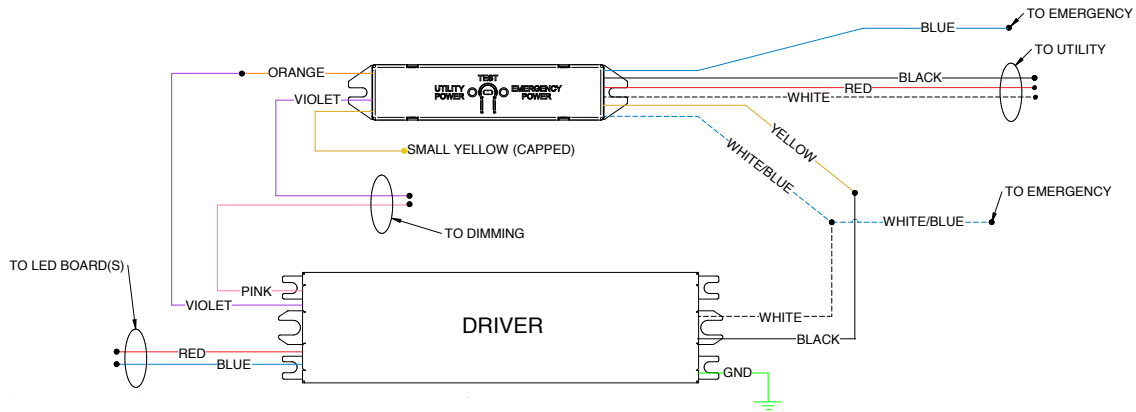

KEY	
Color	Connects With
White/Blue	Emergency Neutral
Blue	Emergency Line
Black	Utility line (Unswitched Hot)
White	Utility Neutral
Red	Switched Hot
Violet	Dimming
Pink	Dimming

CASE 2: DTS WITH INTERNAL NXFM-O OR NXFM-I

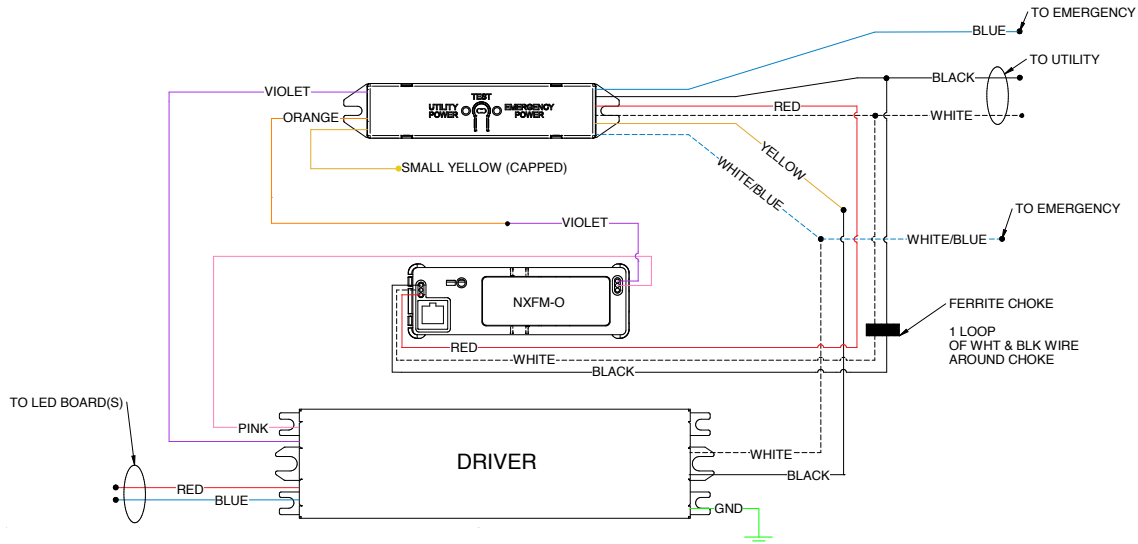

KEY	
Color	Connects With
White/Blue	Emergency Neutral
Blue	Emergency Line
Black	Utility line (Unswitched Hot)
White	Utility Neutral

DTS Dimming Bypass Module

WIRING DIAGRAMS

CASE 3: DTS WITH INTERNAL NXFM-LV

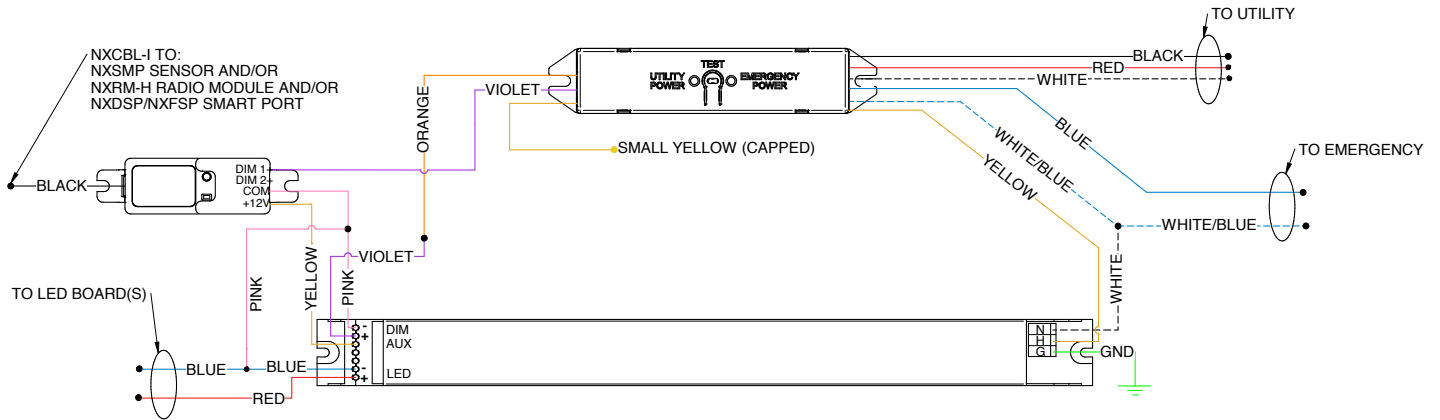

KEY	
Color	Connects With
White/Blue	Emergency Neutral
Blue	Emergency Line
Black	Utility line (Unswitched Hot)
White	Utility Neutral
Red	Switched Hot

CASE 4: DTS WITH INTERNAL CTC MODULE FOR SpectraSync™

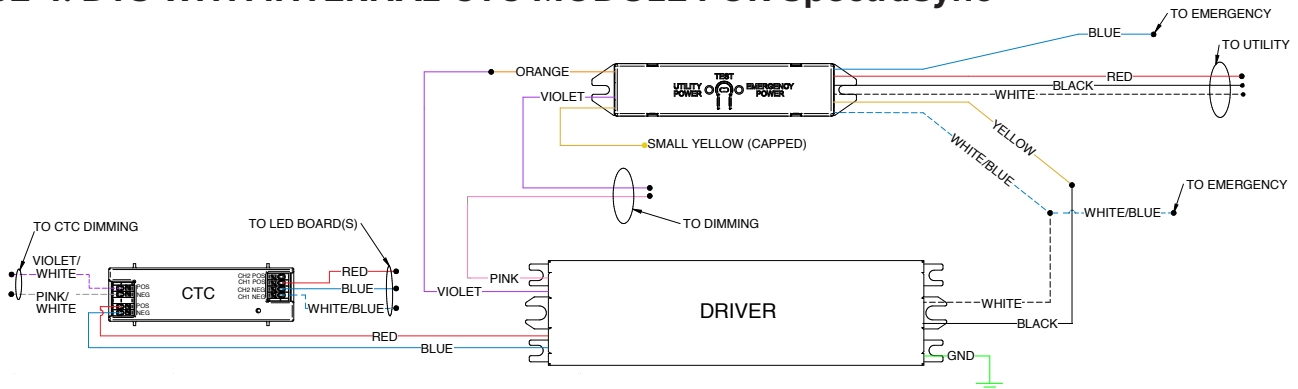

KEY	
Color	Connects With
White/Blue	Emergency Neutral
Blue	Emergency Line
Black	Utility line (Unswitched Hot)
White	Utility Neutral
Red	Switched Hot
Violet	Dimming (+)
Pink	Dimming (-)
Violet/White	CCT Dimming (+)
Pink/White	CCT Dimming (-)

DTS Dimming Bypass Module

WIRING DIAGRAMS

CASE 5: DTS WITH INTERNAL CTC AND NXFM-O OR NXFM-I FOR SpectraSync™ USED WITH NX

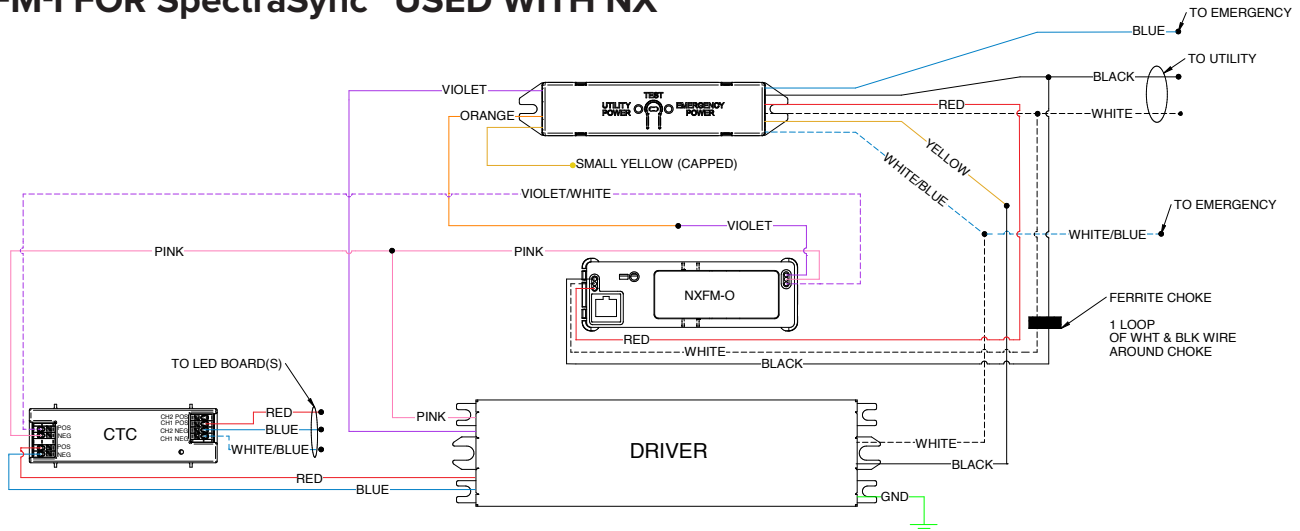

KEY	
Color	Connects With
White/Blue	Emergency Neutral
Blue	Emergency Line
Black	Utility line (Unswitched Hot)
White	Utility Neutral

CASE 6: DTS WITH LUTRON H SERIES DRIVER OR LUTRON 5 SERIES DRIVER

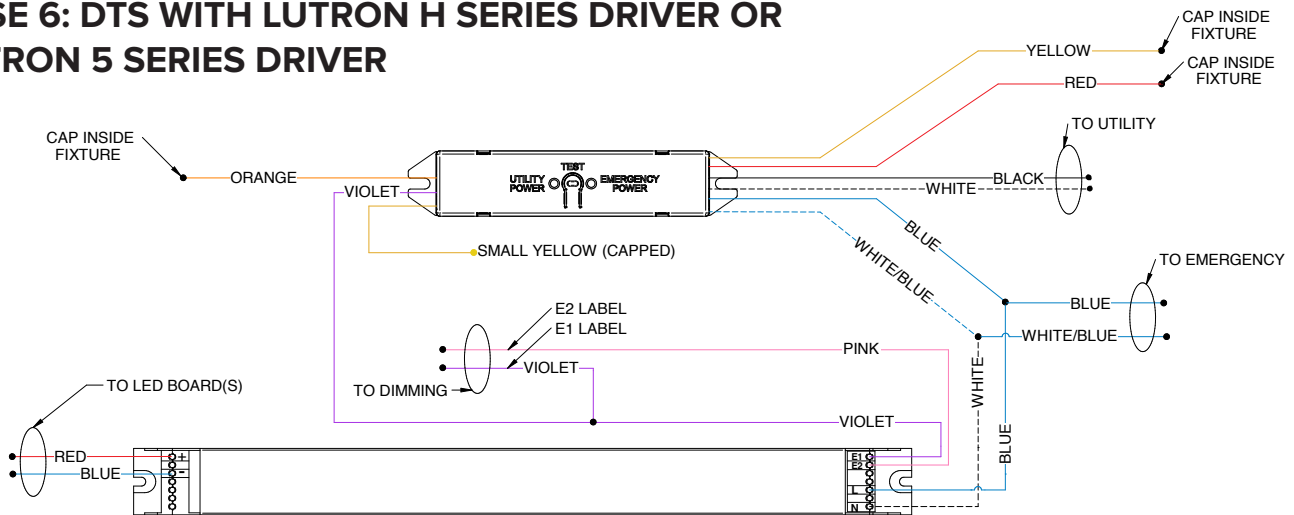

KEY	
Color	Connects With
White/Blue	Emergency Neutral
Blue	Emergency Line
Black	Utility line (Unswitched Hot)
White	Utility Neutral
Red	Switched Hot
Violet	Dimming
Pink	Dimming

DTS Dimming Bypass Module

WIRING DIAGRAMS

CASE 7: DTS WITH INDIVIDUAL FIXTURE LVR OR LVS SENSOR

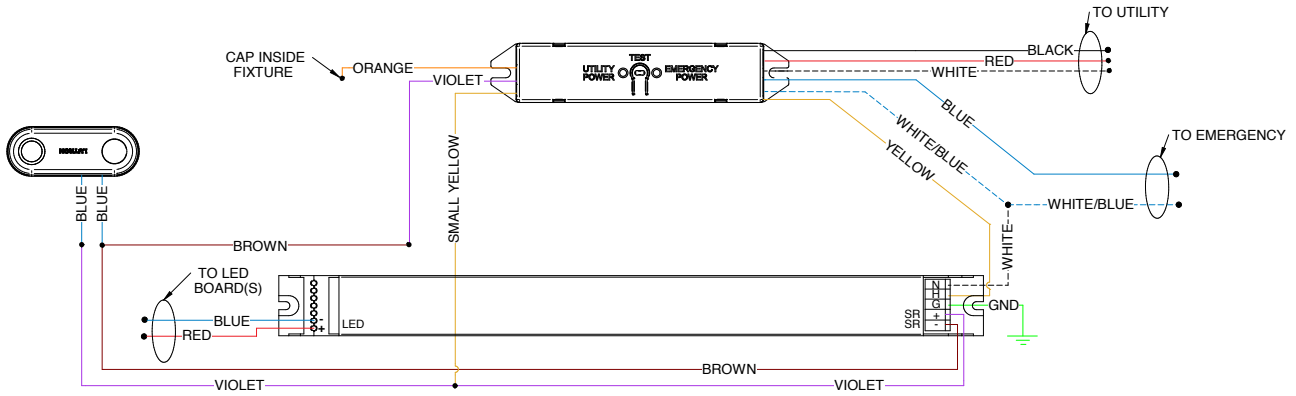

KEY	
Color	Connects With
White/Blue	Emergency Neutral
Blue	Emergency Line
Black	Utility line (Unswitched Hot)
White	Utility Neutral
Red	Switched Hot

CASE 8: DTS WITH INDIVIDUAL FIXTURE ODPG SENSOR

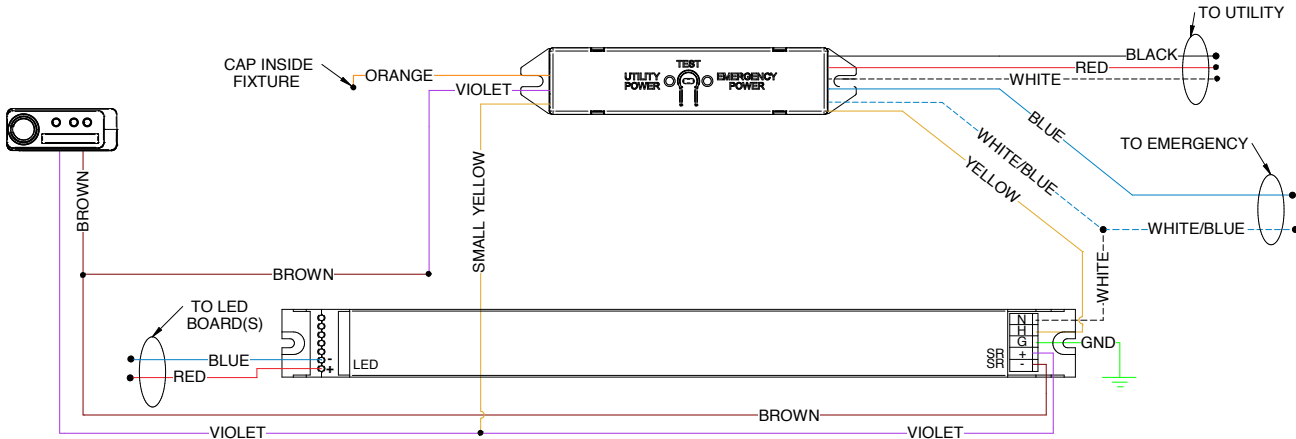

KEY	
Color	Connects With
White/Blue	Emergency Neutral
Blue	Emergency Line
Black	Utility line (Unswitched Hot)
White	Utility Neutral
Red	Switched Hot

DTS Dimming Bypass Module

WIRING DIAGRAMS

CASE 9: DTS WITH FLEX

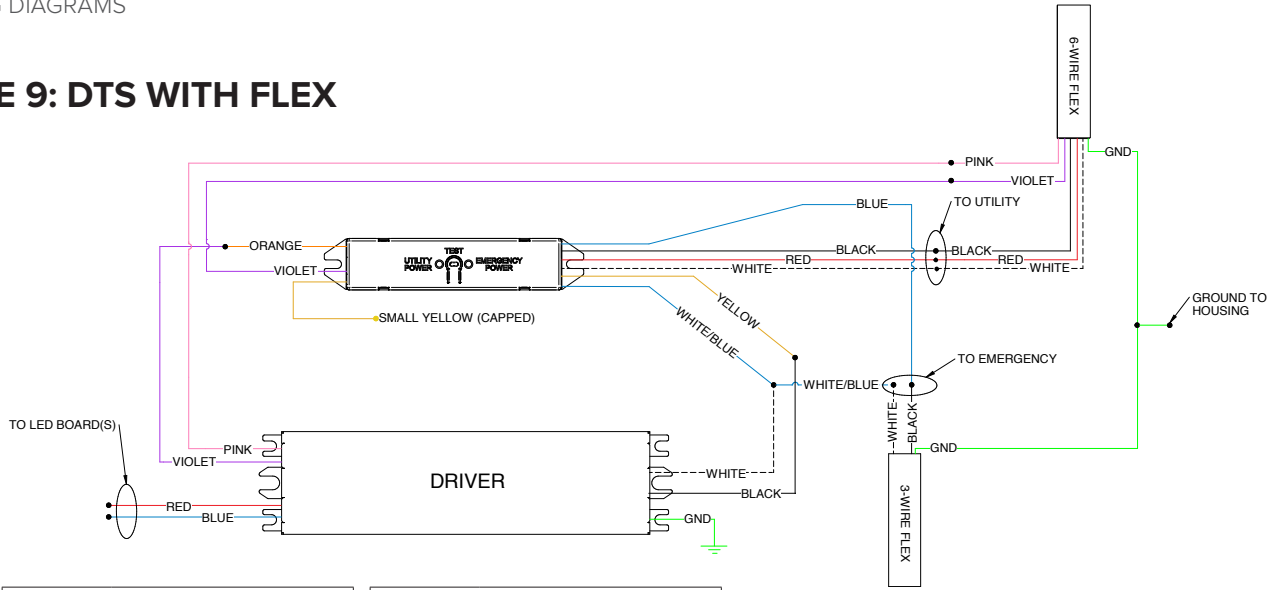

6-WIRE FLEX KEY	
Color	Connects With
Black	Utility Line (Unswitched Hot)
White	Utility Neutral
Red	Switched Hot
Violet	Dimming
Pink	Dimming
Green	Ground

3-WIRE FLEX KEY	
Color	Connects With
White	Emergency Neutral
Black	Emergency Line
Green	Ground

CASE 10: DTS/NXFM-0/I WITH FLEX

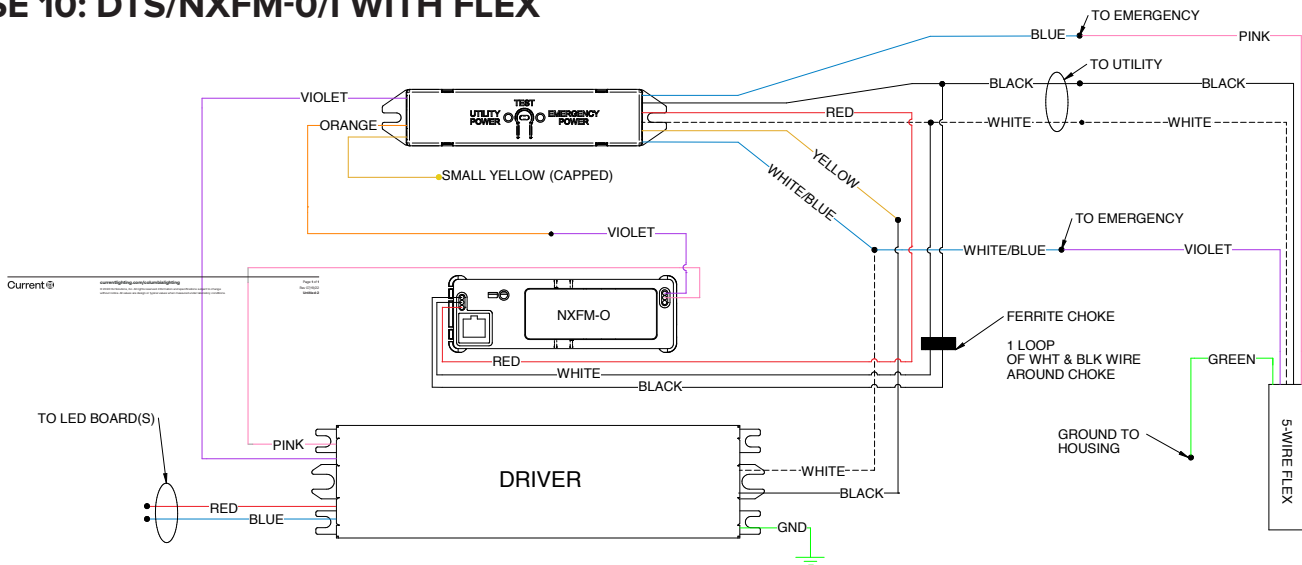

5-WIRE FLEX KEY	
Color	Connects With
Violet	Emergency Neutral
Pink	Emergency Line
Black	Utility line (Unswitched Hot)
White	Utility Neutral
Green	Ground