

WSA10 Wireless Sensor Adapter

Installat on Instruct ons

The Daintree Networks WSA10 Wireless Sensor Adapter is a control component within ControlScope™. The WSA10 enables open, standards based ZigBee wireless control communications with a variety of sensor devices used in HVAC systems.

The WSA10 provides up to four (4) thermistor temperature sensor inputs for temperature monitoring and logging, and up to two (2) 0-10V analog inputs suitable for connection to a broad range of transducers, enabling wireless control and management of wired end-devices within the ControlScope system.

Battery backup within the WSA10 provides continuous temperature logging in the event of a power failure.

Specifications

Input voltage	24VAC/VDC (10mA)
Battery Backup	Type: AA 3.6V lithium thionyl chloride, internal, not replaceable
Operating life:	7 years or more
Battery life:	Min. 5,000 hours (@25°C op. temp), Backup operation only
Data logging capacity when on battery	14 days; 5 minute sampling intervals, Thermistor inputs only
Inputs	
Resistance:	(4) Thermistor, 10K Type 2
Accuracy:	+/- 0.5°C @-10°C to 45°C (14°F to 113°F) +/- 1°C @-30°C to 65°C (-22°F to 149°F)
Voltage:	(2) 0-10VDC
Accuracy:	+/- 2% of span (without calibration)
Radio properties	2.4 GHz, +8 dBm, Range dependent on RF propagation variables
Operating environment	Relative humidity 5% to 95%, non-condensing Temperature: 32° to 122°F (0° to 50°C)
Compliance	US: FCC Part 15 Canada: IC
Mounting	Wall, ceiling, enclosure screw mount
Dimensions	1.18" W x 0.98" H x 7.03" L (30mm W x 25mm H x 178.5mm L)
ControlScope Manager compatibility	Release version 3.1 or later



Installation Process







- 1. Disconnect power to the 24V power supply before installation.** Confirm that power is off before continuing.
 - 2. IMPORTANT:** Use the provided Plan label to identify the wireless-adapted sensor location on the building's floorplan.
 - Mount the WSA10 on a flat surface in the HVAC packaged unit, or in the facility's electrical/mechanical room. See **Mounting**.
 - Connect low voltage wiring between the WSA10 and the power supply and sensors as appropriate. Connect the sensor cable shield drain wire as appropriate. Improper connection of the shield drain may cause incorrect or unstable sensor readings. See **Wiring**.
 - Check wiring then restore power to the power supply.
 - Ensure the WSA10 green Power  LED is On.
 - Press and hold the **Reset** button on the WSA10 for **3 seconds** to reset the unit. Release the button when the green Joined  LED and the red Error  LEDs begin flashing.
- IMPORTANT:** Reset the WSA10 as described above after adding sensors or making any change to wiring connections.

Fig. 1: LED indicators

-  **Error/Reset**—On when the Wireless Adapter is in an error state. Flashes to indicate unit Reset (red).
-  **Joined**—On when the Wireless Adapter has joined a ZigBee® network. Flashes to indicate Reset (green).
-  **Power**—On when power is applied to the Wireless Adapter (green).

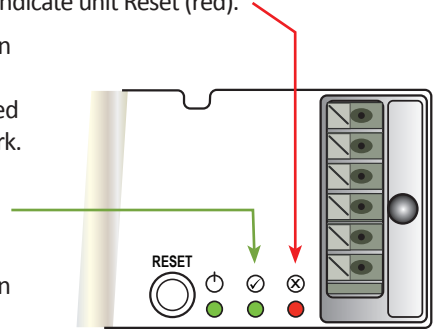

Wiring

Fig. 2: WSA10 terminal connections 0-10V sensors and NTC thermistors, using a DC Power Supply

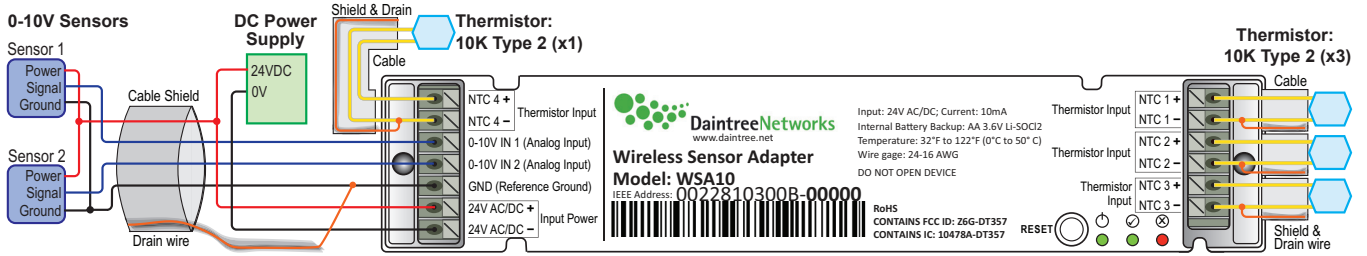

Fig. 3: WSA10 terminal connections for 0-10V sensors and NTC thermistors, using a WFA100-SN for DC Power Supply
 NOTE: WFA100-SN is inside an approved electrical fixture, or enclosure to provide double insulation of the line voltage wiring.

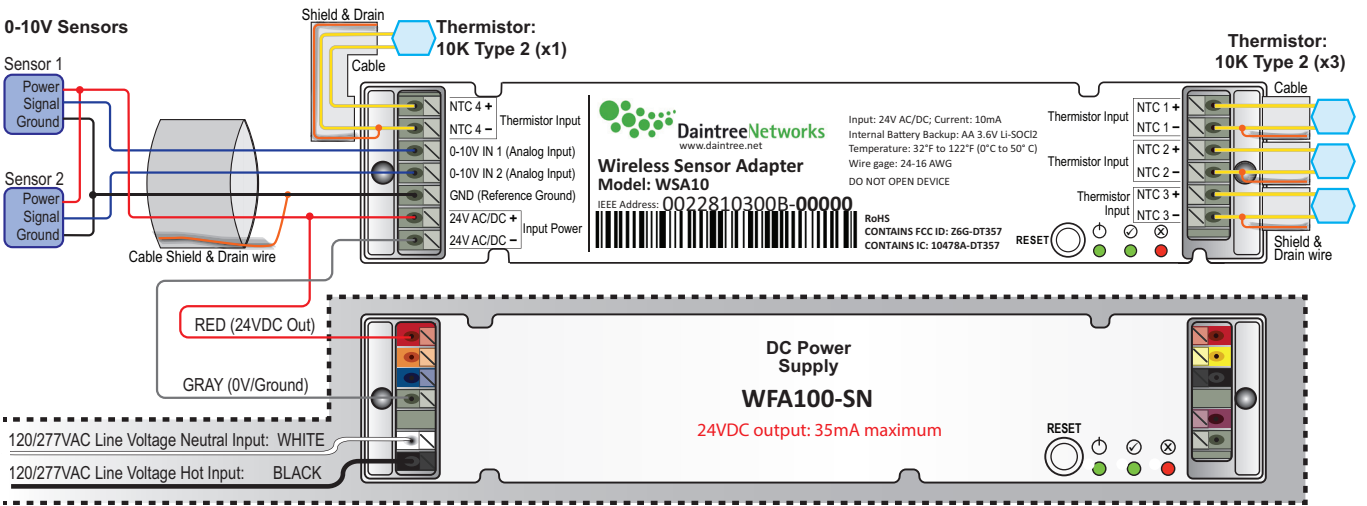

Fig. 4: WSA10 terminal connections for 0-10V sensor and NTC thermistors, using a WGA100 or WA100-family adaptor for DC Power Supply

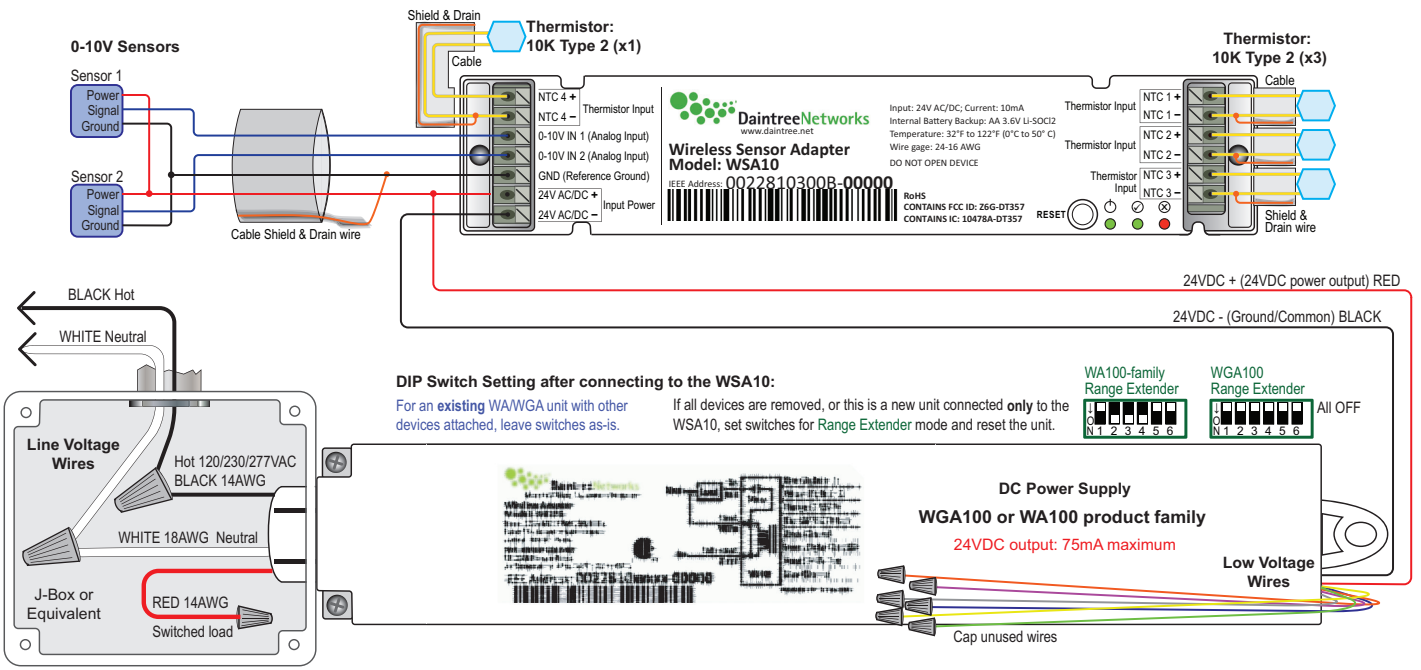

Fig. 5: WSA10 terminal connections for 0-10V sensors and NTC thermistors, using an AC Power Supply

To reduce AC noise on the sensor signal line, install the AC to DC power supply near the WSA10, rather than near the sensor(s).

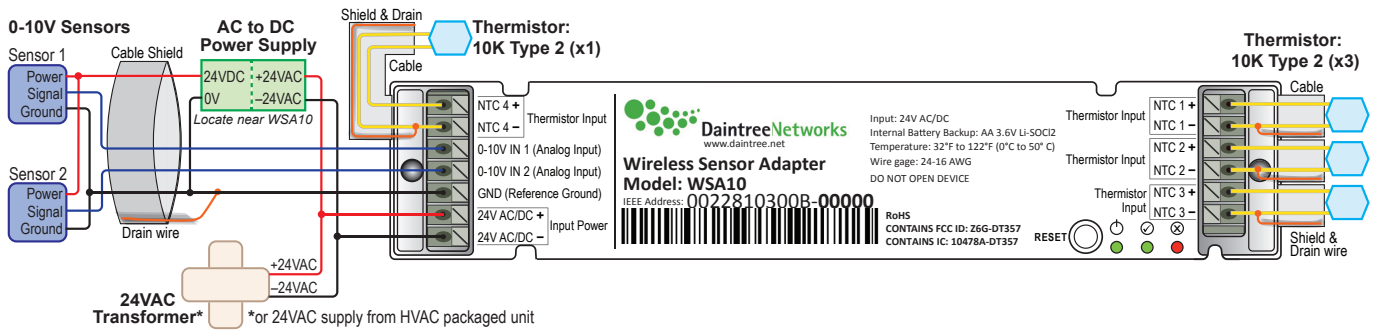

Fig. 6: WSA10 terminal connections for 4-20mA sensors and NTC thermistors, using a DC Power Supply

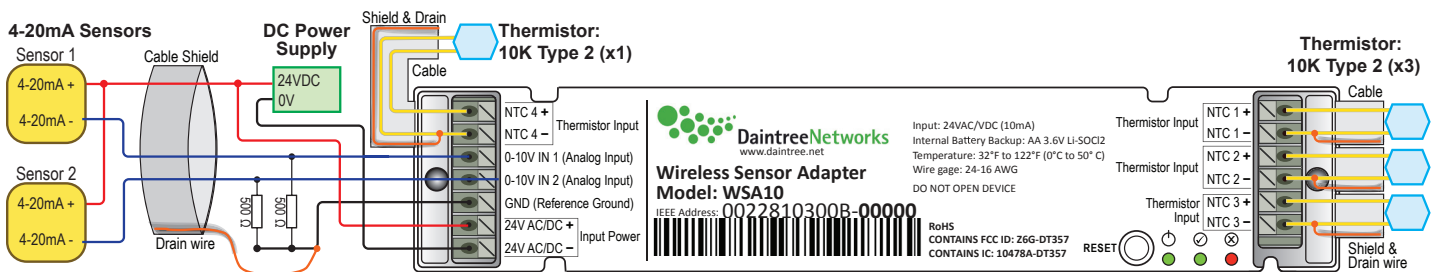
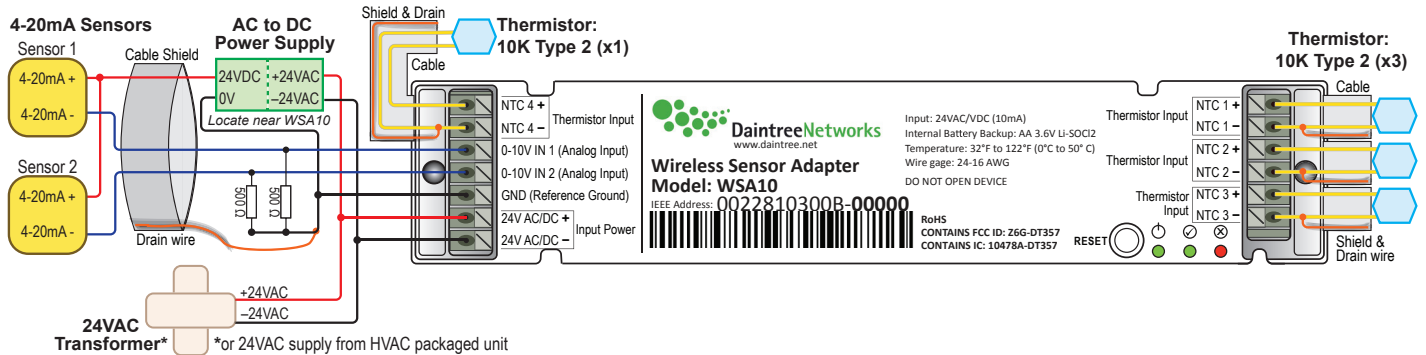

Fig. 7: WSA10 terminal connections for 4-20mA sensors and NTC thermistors, using an AC Power Supply

To reduce AC noise on the sensor signal line, install the AC to DC power supply near the WSA10, rather than near the sensor(s).



⚠ CAUTION: Risk of electrical shock ⚠

- Disconnect all power before installation •
- Wiring connectors are not supplied. UL recognized wiring connectors must be used in the installation •
- Each terminal can accept one conductor only. Connect only one 24AWG to 16AWG wire to any terminal •
- All installation and maintenance of line voltage equipment must be performed by a qualified electrician •
- The WSA10 must be installed in accordance with all local, state, and national electrical codes and requirements •
- **If the sensor cable includes a shield, terminate the end closest to the WSA10 as shown in the applicable wiring diagram •**
 - **Follow sensor manufacturer's instructions and recommendations for all sensor connections •**

CLASS 2 WIRING: All field wiring shall be suitable for Class 1, Electric Light and Power, or Class 2, 3 wirings are routed separately and secured to maintain separation between: 1) Class 2 wiring and all other class wiring, and 2) limited energy circuit conductors from unlimited energy circuit conductors.

Mounting

The WSA10 is designed to be mounted to a flat surface using two screws. Alternatively, the mounting tabs at the end of the WSA10 enclosure can be snapped off with pliers to make the unit length up to 0.63" (3/4" or 16mm) smaller to fit into tighter spaces. The grooves on the mounting tabs mark the snap-off point, approximately 3/8" (8mm) from each end of the unit. Note that when the tabs are removed the mounting holes are lost, so the unit has to be mounted or affixed by other means, such as permanent double-sided adhesive tape.

Fig. 8: Mounting Template (observe measurements, illustration may not be actual size).

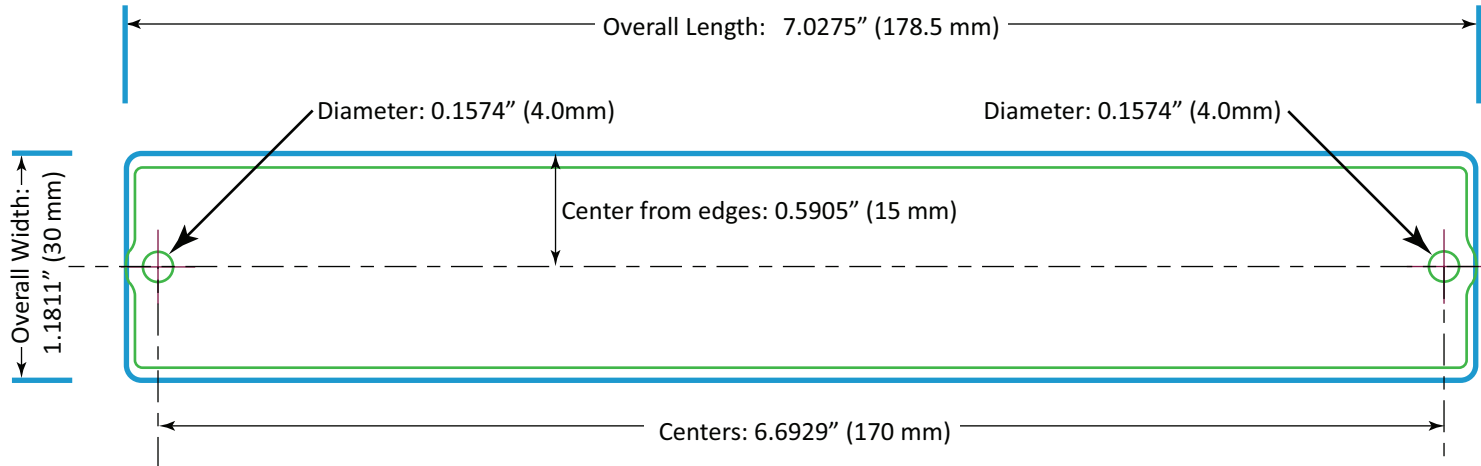

IMPORTANT NOTICES

Record IEEE Addresses

If you have not already done so, be sure that each WSA10's IEEE address (last 4 or 5 digits) is recorded on the facility floor plan. You can use the 4 or 5 digit **Plan** label supplied with the WSA10 or you can write the last 4 or 5 digits on the floor plan. This information will be used during the commissioning process.

After the system installation is complete, a marked-up copy of the facility floor plan showing the identity and location of each wireless adapter (including associated sensors) should be available. This will simplify and expedite the commissioning process.

Joining the ZigBee Network

After the WSA10 is powered-up, it is ready to communicate with the Daintree Wireless Area Controller (WAC) and the Daintree ControlScope Manager (CSM) web-based user interface. Upon commissioning, the WSA10 "Join" LED turns on solid and remains on as long as the WSA10 is included in the ZigBee Network.

After joining the network, signals from the low voltage devices connected to the WSA10 pass through the WSA10 and are sent wirelessly to the ControlScope network. For more information about configuring the system, see the instructions and on-line help provided with the ControlScope Manager application.

FCC warning message

This equipment has been tested and found to comply with the limits for a Class B digital device, pursuant to Part 15 of the FCC Rules. These limits are designed to provide reasonable protection against harmful interference in a residential installation. This equipment generates, uses and can radiate radio frequency energy and, if not installed and used in accordance with the instructions, may cause harmful interference to radio communications. However, there is no guarantee that interference will not occur in a particular installation. If this equipment does cause harmful interference to radio or television reception, which can be determined by turning the equipment off and on, the user is encourage to try to correct the interference by one or more of the following measures:

- Reorient or relocate the receiving antenna
- Increase the separation between the equipment and receiver
- Connect the equipment into an outlet on a circuit different from that to which the receiver is connected
- Consult the dealer or an experienced radio/TV technician for help

ZigBee® is a registered trademark of the ZigBee Alliance.