

Wireless Sensor Adapter

(WSA10)



BEFORE YOU BEGIN

Read these instructions completely and carefully. Save these instructions for future use.



⚠️ WARNING

Risk of electrical shock. Disconnect power before servicing or installing product.
Install in accordance with National Electric Code and local codes.

The **WSA10 Wireless Sensor Adapter** is a control component that enables open, standards based wireless control communications with a variety of sensor devices used in HVAC systems.

The WSA10 provides up to four (4) thermistor temperature sensor inputs for temperature monitoring and logging, and up to two (2) 0-10V analog inputs suitable for connection to a broad range of transducers, enabling wireless control and management of wired end-devices within the Daintree Networked platform.

① Installation Process

1. Disconnect power to the 24V power supply before installation. Confirm that power is off before continuing.
2. **IMPORTANT:** Use the provided Plan label to identify the wireless-adapted sensor location on the building's floorplan.
3. Mount the WSA10 on a flat surface in the HVAC packaged unit, or in the facility's electrical/mechanical room. See **Mounting**.
4. Connect low voltage wiring between the WSA10 and the power supply and sensors as appropriate. Connect the sensor cable shield drain wire as appropriate. Improper connection of the shield drain may cause incorrect or unstable sensor readings. See **Wiring**.
5. Check wiring then restore power to the power supply.
6. Ensure the WSA10 green Power LED is On.
7. Press and hold the Reset button on the WSA10 for 3 seconds to reset the unit. Release the button when the green Joined LED and the red Error LEDs begin flashing.

IMPORTANT: Reset the WSA10 as described above after adding sensors or making any change to wiring connections.

⚠️ CAUTION

Risk of injury. Wear safety glasses and gloves during installation and servicing.

LED Indicators

	Error/Test — On when the Wireless Adapter is in an error state. Flashes to indicate unit Reset and during Installation Test Mode (red).
	Joined — On when the Wireless Adapter has joined a ZigBee® network. Flashes to indicate Reset and during sensor Installation Test Mode (green).
	Power — On when power is applied to the Wireless Adapter (green).

Figure 1: LED indicators

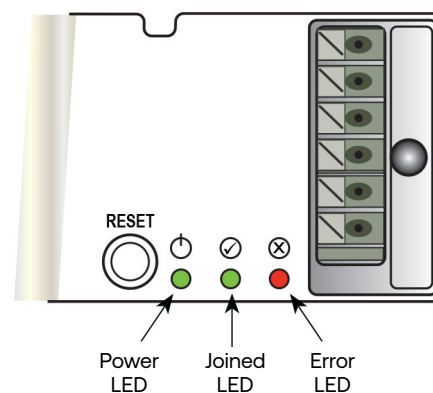

② Wiring

Figure 2: WSA10 terminal connections 0-10V sensors and NTC thermistors, using a DC Power Supply

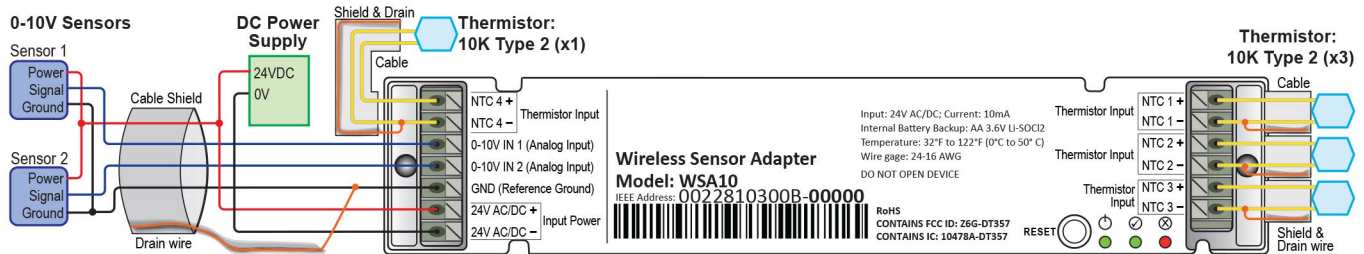
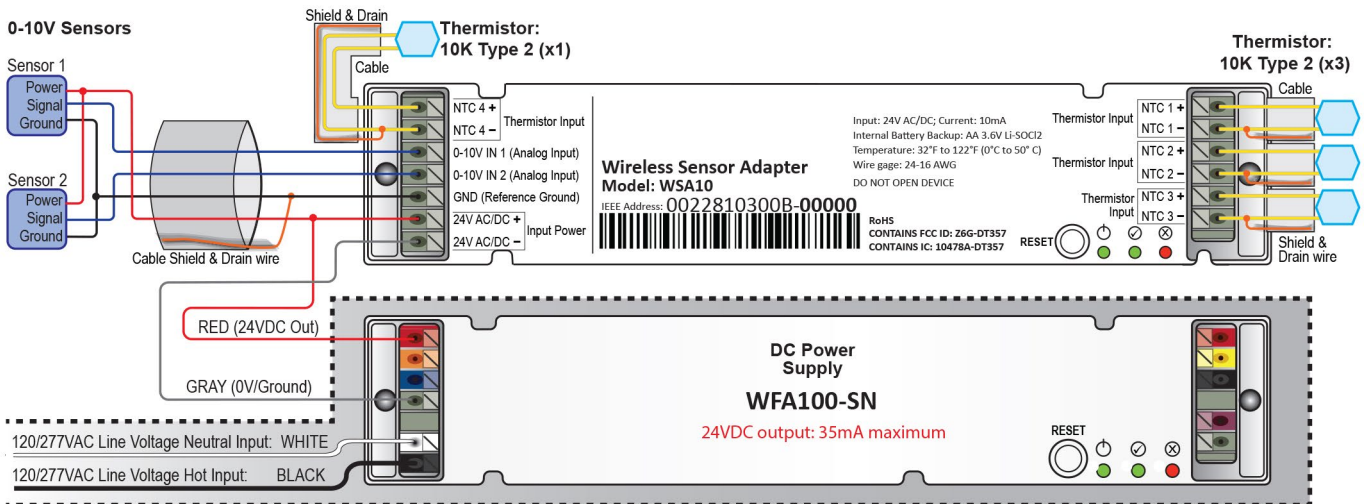

Figure 3: WSA10 terminal connections for 0-10V sensors and NTC thermistors, using a WFA100-SN for DC Power Supply

NOTE: WFA100-SN is inside an approved electrical fixture, or enclosure to provide double insulation of the line voltage wiring.



② Wiring Continued

Figure 4: WSA10 terminal connections for 0-10V sensor and NTC thermistors, using a WGA100 or WA100-family adaptor for DC Power Supply

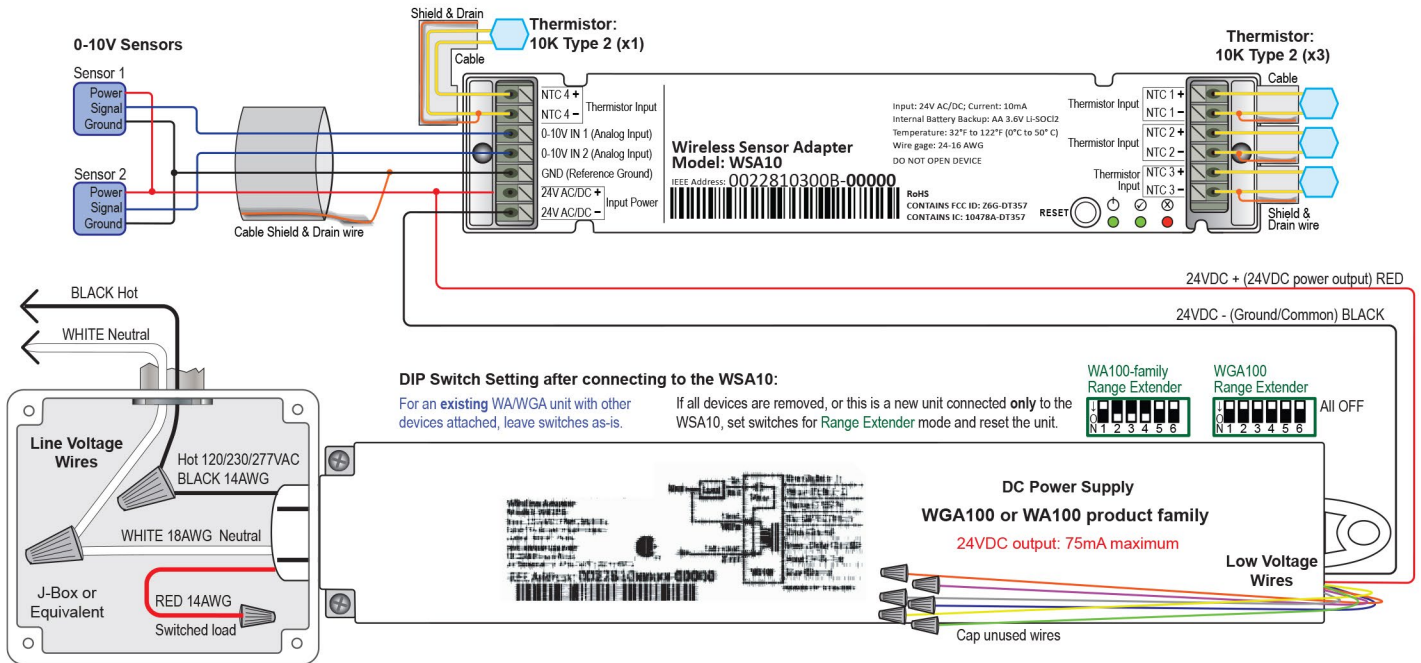
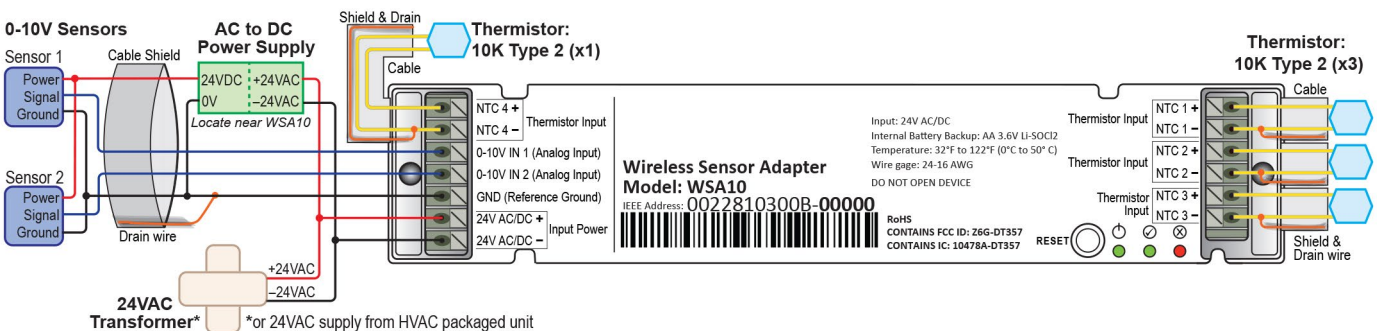

Figure 5: WSA10 terminal connections for 0-10V sensors and NTC thermistors, using an AC Power Supply adaptor for DC Power Supply

To reduce AC noise on the sensor signal line, install the AC to DC power supply near the WSA10, rather than near the sensor(s).



② Wiring Continued

Figure 6: WSA10 terminal connections for 4-20mA sensors and NTC thermistors, using a DC Power Supply adaptor for DC Power Supply

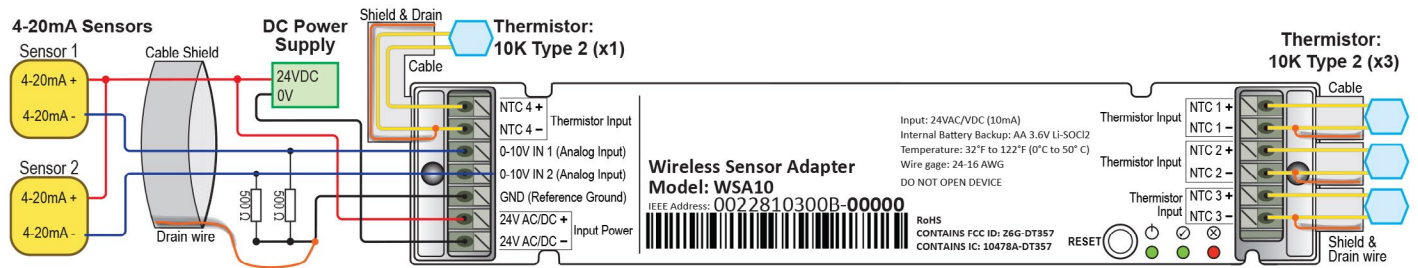
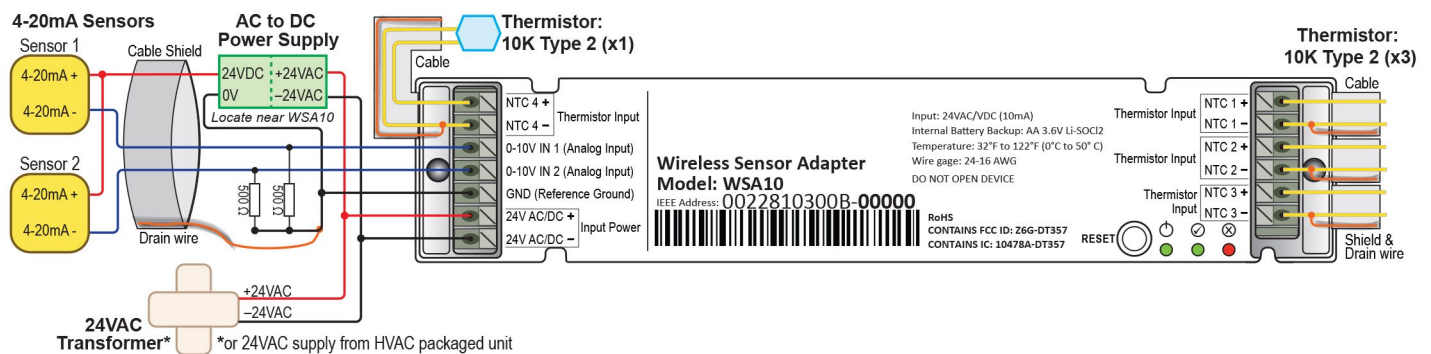

Figure 7: WSA10 terminal connections for 4-20mA sensors and NTC thermistors, using an AC Power Supply for DC Power Supply

To reduce AC noise on the sensor signal line, install the AC to DC power supply near the WSA10, rather than near the sensor(s).



CAUTION

Risk of electrical shock. Disconnect all power before installation. Wiring connectors are not supplied. UL recognized wiring connectors must be used in the installation. Each terminal can accept one conductor only. Connect only one 24AWG to 16AWG wire to any terminal. All installation and maintenance of line voltage equipment must be performed by a qualified electrician. The WSA10 must be installed in accordance with all local, state, and national electrical codes and requirements. If the sensor cable includes a shield, terminate the end closest to the WSA10 as shown in the applicable wiring diagram. Follow sensor manufacturer's instructions and recommendations for all sensor connections.

CLASS 2 WIRING:

All field wiring shall be suitable for Class 1, Electric Light and Power, or Class 2, 3 wirings are routed separately and secured to maintain separation between: 1) Class 2 wiring and all other class wiring, and 2) limited energy circuit conductors from unlimited energy circuit conductors.

③ Mounting

The WSA10 is designed to be mounted to a flat surface using two screws. Alternatively, the mounting tabs at the end of the WSA10 enclosure can be snapped off with pliers to make the unit length up to 0.63" (3/4" or 16mm) smaller to fit into tighter spaces. The grooves on the mounting tabs mark the snap-off point, approximately 3/8" (8mm) from each end of the unit.

Note that when the tabs are removed the mounting holes are lost, so the unit has to be mounted or affixed by other means, such as permanent double-sided adhesive tape.

Figure 8: Mounting Template (observe measurements, illustration may not be actual size).for DC Power Supply

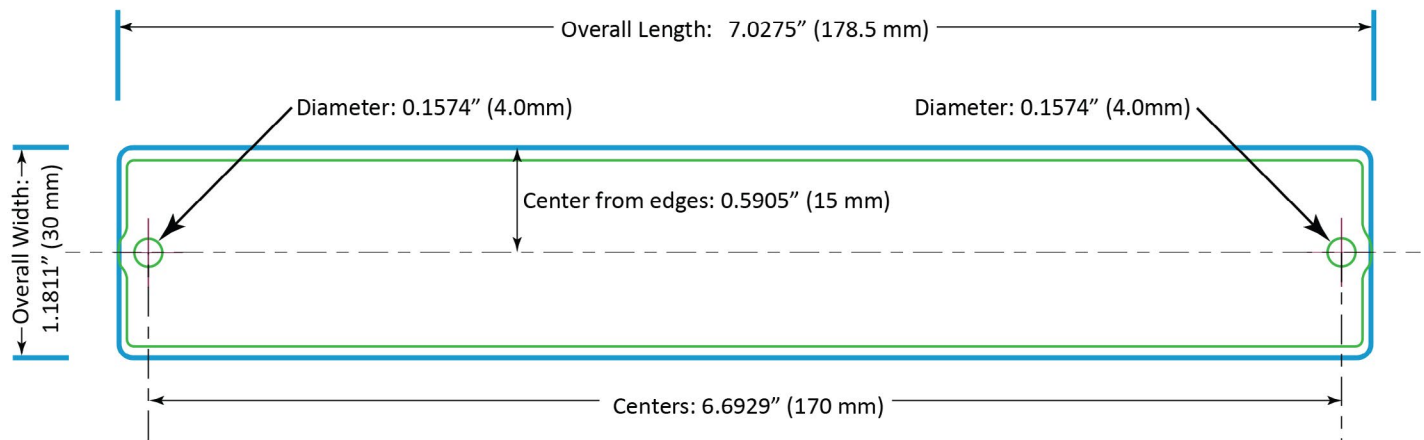

④ Important Notices

Record IEEE Addresses

If you have not already done so, be sure that each WSA10's IEEE address (last 4 or 5 digits) is recorded on the facility floor plan. You can use the 4 or 5 digit Plan label supplied with the WSA10 or you can write the last 4 or 5 digits on the floor plan. This information will be used during the commissioning process.

After the system installation is complete, a marked-up copy of the facility floor plan showing the identity and location of each wireless adapter (including associated sensors) should be available. This will simplify and expedite the commissioning process.

⑤ Joining the Zigbee Network

After the WSA10 is powered-up, it is ready to communicate with the Daintree Wireless Area Controller (WAC) and the ControlScope web-based user interface. Upon commissioning, the WSA10 "Join" LED turns on solid and remains on as long as the WSA10 is included in the ZigBee Network.

After joining the network, signals from the low voltage devices connected to the WSA10 pass through the WSA10 and are sent wirelessly to Daintree Networked. For more information about configuring the system, see the instructions and on-line help provided with the Daintree ControlScope web application.

⑥ Operation with ControlScope Manager

Once joined to the ZigBee network, the WSA10 and its connected devices are assigned to zones using the Zone and Device Configuration page. Notice that each connected input is listed as a separate device. The Device ID and Model columns include terminal identifiers for each connected device. These identifiers are automatic and carry over to both the Devices page and Zone Temperature Logging reports.

Each connected input is also assigned a Device Profile, which determines if an alarm is generated when the sensor reports a reading outside of the designated range.

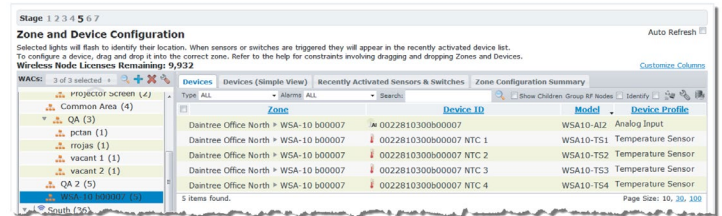

⑦ Reports

The Zone Temperature Analysis report displays temperature and time as reported by a temperature sensor or thermostat. It also displays a histogram representing the time spent at various temperatures over the report time period.

When a time is selected on the histogram, the number of hours spent above or below the reported temperature also displays.

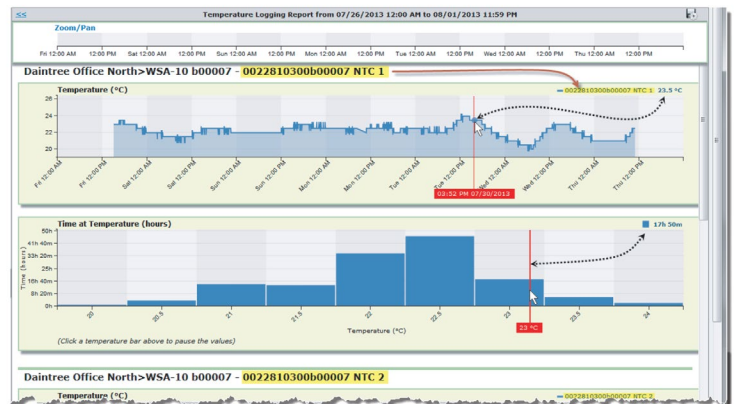

⑧ Alarms

An input's Device Profile can be configured to generate a threshold alarm when a temperature is outside of designated limits, as shown below. When an input is shorted or open, a failure alarm is raised against the device, as shown below.

Alert Emails

An Email Rule can be set up to automatically send an email when a temperature alarm is generated, or when other alerts occur. See Email Alert Rules in the CSM online help for more information.

Active Alarms							Event and Alarm Definitions and Troubleshooting	
Raised	Category	Classification	Wireless Area Controller	Zone	Device	Event ID	Description	
7/30/13 2:33:19 PM	Device	System Status	North (0022810101d40000)	WSA-10 b00007	0022810300b00007	Device Threshold Out of Range	The reported value from the device is not within the permitted threshold: reported 22.5 °C	
7/30/13 2:32:05 PM	Device	System Status	North (0022810101d40000)	WSA-10 b00007	0022810300b00007	Logged Device Threshold Out of Range	The reported value from the logged device is not within the permitted threshold: reported 22.5 °C	

9 Regulatory Information

Caution: Any changes or modifications not expressly approved by the party responsible for compliance could void the user's authority to operate this equipment.

This device complies with part 15 of the FCC Rules. Operation is subject to the following two conditions: (1) This device may not cause harmful interference, and (2) this device must accept any interference received, including interference that may cause undesired operation.

This device contains license-exempt transmitter(s)/receiver(s) that comply with Innovation, Science and Economic Development Canada's license-exempt RSS(s). Operation is subject to the following two conditions:

1. This device may not cause interference.
2. This device must accept any interference, including interference that may cause undesired operation of the device.

L'émetteur/récepteur exempt de licence contenu dans le présent appareil est conforme aux CNR d'Innovation, Sciences et Développement économique Canada applicables aux appareils radio exempts de licence. L'exploitation est autorisée aux deux conditions suivantes:

1. L'appareil ne doit pas produire de brouillage;
2. L'appareil doit accepter tout brouillage radioélectrique subi, même si le brouillage est susceptible d'en compromettre le fonctionnement.

Note: This equipment has been tested and found to comply with the limits for a Class B digital device, pursuant to part 15 of the FCC Rules. These limits are designed to provide reasonable protection against harmful interference in a residential installation. This equipment generates, uses and can radiate radio frequency energy and, if not installed and used in accordance with the instructions, may cause harmful interference to radio communications. However, there is no guarantee that interference will not occur in a particular installation. If this equipment does cause harmful interference to radio or television reception, which can be determined by turning the equipment off and on, the user is encouraged to try to correct the interference by one or more of the following measures:

- Reorient or relocate the receiving antenna.
- Increase the separation between the equipment and receiver.
- Connect the equipment into an outlet on a circuit different from that to which the receiver is connected.
- Consult the dealer or an experienced radio/TV technician for help.

To satisfy FCC/ISED RF exposure requirements a separation distance of 20 cm or more must be maintained between the antenna of this device and persons during operation. Operation at closer than 20cm is not permitted.



Pour être conforme aux limites d'exposition aux ondes RF des normes FCC/ISED, une distance de séparation d'au moins 20 cm doit être maintenue entre l'antenne de cet appareil et toute personne pendant son opération. Mettre en opération cet appareil à une distance plus rapprochée que 20 cm n'est pas permis.

Hereby, Current Lighting Solutions, LLC declares that the radio equipment type WSA10 is in compliance with Directive 2014/53/EU. The full text of the EU declaration of conformity is available at the following internet address: www.LED.com

SPECIFICATIONS

Input Voltage:	24VAC/VDC (10mA)
Battery Backup:	Type: AA 3.6V lithium thionyl chloride, internal, not replaceable
Operating Life:	7 years or more
Battery Life:	Min. 5,000 hours (@25°C op. temp), Backup operation only
Inputs:	
Resistance:	(4) Thermistor, 10K Type 2
Accuracy:	+/- 0.5°C @-10°C to 45°C (14°F to 113°F) +/- 1°C @-30°C to 65°C (-22°F to 149°F)
Voltage:	(2) 0-10VDC
Accuracy:	+/- 2% of span (without calibration)
Radio Properties:	2.4 GHz, +8 dBm, Range dependent on RF propagation variables
Operating Environment:	Relative humidity 5% to 95%, non-condensing Temperature: 32° to 122°F (0° to 50°C)
Mounting:	Wall, ceiling, enclosure screw mount
Dimensions:	1.18" W x 0.98" H x 7.03" L (30mm W x 25mm H x 178.5mm L)
ControlScope Manager Compatibility:	Release version 3.1 or later

PRODUCT CERTIFICATIONS

Contains:
 FCC ID: Z6G-DT357
 IC: 10478A-DT357
 CAN ICES-005 (B) / NMB-005 (B)



WSA 10

CAUTION

RISK OF EXPOSURE IF BATTERY IS REPLACED BY AN INCORRECT TYPE. DISPOSAL OF USED BATTERIES ACCORDING TO THE INSTRUCTIONS.

Questions:

Web: gecurrent.com/daintree

Phone: 1-866-855-8629

Email: daintree.support@gecurrent.com

Current Lighting Solutions, LLC

25825 Science Park, Suite 400
 Beachwood, OH 44122

These instructions do not purport to cover all details or variations in equipment nor to provide for every possible contingency to be met in connection with installation, operation or maintenance. Should further information be desired or should particular problems arise which are not covered sufficiently for the purchaser's purposes, the matter should be referred to Current.