

# Daintree™ Wireless General Purpose Adapter

(WGA100)



## BEFORE YOU BEGIN

Read these instructions completely and carefully.  
Save these instructions for future use.



### ⚠️ WARNING

**Risk of electrical shock.** Disconnect power before servicing or installing product.  
**Install in accordance with National Electric Code and local codes.**

### ⚠️ CAUTION

**Risk of injury.** Wear safety glasses and gloves during installation and servicing.

Daintree's WGA100 Wireless General Purpose Adapter forms part of the Daintree ControlScope control solution for commercial and industrial buildings. It transmits and receives messages over the wireless ZigBee® network to monitor and control a variety of devices used in building management.

The WGA100 is an AC powered device that provides On/Off switching and 0-10V analog control as well as reporting and monitoring capability of binary and 0-10V analog signal inputs for non-lighting applications. It provides power for low voltage sensors, switches, and analog control signals and provides the wireless adaptation that enables them to communicate with the rest of the wireless control solution. The control signals to and from these devices pass between the WGA100 and the Wireless Area Controller (WAC) in the ControlScope network.

## ① Installation Process

1. **Disconnect power before installation.** Turn off all power to affected devices by turning off circuit breakers. Confirm that power is off at all devices before continuing installation.
2. Set the WGA100 DIP switches to support the device(s) it will monitor or control. See **DIP Switch Settings (pages 2-3)**.
3. **IMPORTANT:** Put the WGA100's "Plan" label (with 4-5 digits of the IEEE address) on the floor plan to indicate its location.
4. Mount the WGA100 to a junction box or enclosure approved for the application. See **Mounting (page 8)**.
5. Connect low voltage wiring from the WGA100 to the device(s) as appropriate for your application. See **Wiring (pages 4-7)**.
6. Connect line voltage wiring from the supply circuit to the WGA100 as described in **Wiring (pages 4-7)**.

8. Ensure the WGA100 green Power ⏻ LED is On.
9. Press and hold the blue RESET button on the WGA100 for 3 seconds to reset the unit. Release the button when the green Joined ✓ LED and the red Error ⊗ LEDs begin flashing.
10. Perform the installation test appropriate for your application. See **Installation Tests (page 9)**.



### LED Indicators

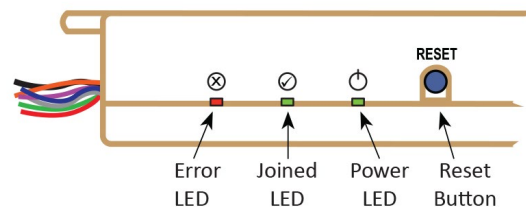

- ⊗ **Power—On** when power is applied to the Wireless Adapter (green).
- ✓ **Joined—On** when the Wireless Adapter has joined a ZigBee® network. Flashes to indicate Reset and during sensor Installation Test Mode (green).
- ⏻ **Error—On** when the Wireless Adapter is in an error state. Flashes to indicate unit Reset and during Installation Test Mode (red).



## ② DIP Switch Settings

DIP switch settings enable the WGA100 interfaces so that it can identify the types of devices connected to it for control, monitoring, and wireless adaptation. Each of the DIP switches enables a separate interface. Interfaces can be enabled in any combination.

Configure the DIP switch settings only as shown in this instruction for the devices that you connect to the WGA100.





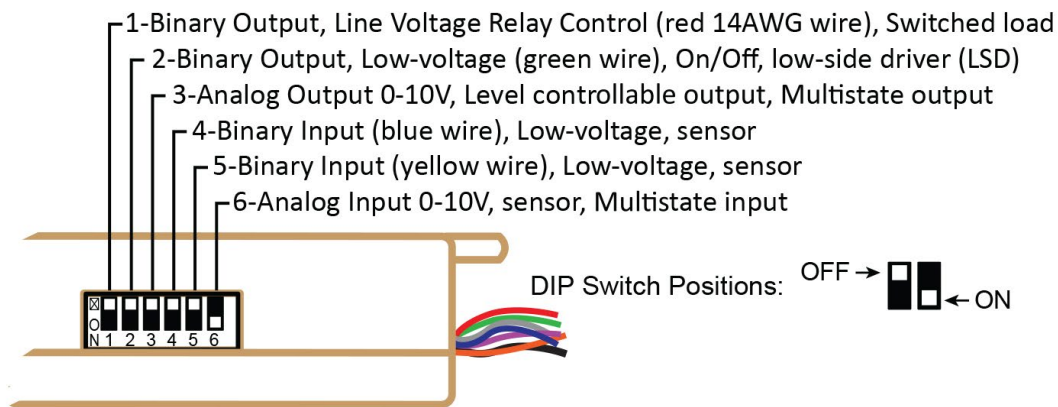



After you change the DIP switch settings, you need to press the blue Reset button for 3 seconds to reset the unit. Release the button when the green Joined  and red Error  LEDs begin flashing.

**Fig. 1: DIP switch location**



**Fig. 2: DIP Switch Table — See Interface Type Descriptions for information about each option.**

DIP Switch Positions: OFF →  ← ON

Interface Type	Interfaces can be enabled in any combination.	Wire color	DIP Setting
Binary Output: Line voltage On/Off (Switched Load)		Red (14 AWG)	
Binary Output: Low voltage, On/Off (LSD)		Green (22 AWG)	
Analog Output: 0-10V, level controllable, multistate		Violet (22 AWG)	
Binary Input: Low voltage, binary		Blue (22 AWG)	
Binary Input: Low voltage, binary		Yellow (22 AWG)	
Analog Input: 0-10V, multistate		Orange (22 AWG)	
All enabled.	All switches On.		
All inputs/outputs disabled. WGA100 is in Range Extender mode whereby it joins a network and acts only as a wireless repeater to increase the wireless network range and/or improve reliability.	All switches Off.		

### ③ Interface Type Descriptions

To connect a device to an interface, use the wire leads indicated in the DIP Switch Table and in **Figure 3: Wiring Identification**.

#### **Switch 1. Binary Output: Line voltage On/Off (Switched Load)**

This output provides up to 15A/1hp switched line voltage (switched to Hot/Active) to the device connected to the WGA100's 14AWG red wire. Examples for this output may include powering an electrical outlet, equipment bench, contactor, pump or motor when a space is occupied, as determined by ControlScope configuration.

#### **Switch 2. Binary Output: Low voltage, On/Off (LSD)**

This binary output is used to open and close relays and switches. An example would be to turn on a ventilation fan, or energize a dry contact on a setback thermostat when a room is occupied.

**Note:** When both Switch 1 and Switch 2 are enabled, CSM identifies the Switch 1 interface as BO1, and the Switch 2 interface as BO2.

#### **Switch 3. Analog Output: 0-10V, level controllable, multistate**

Analog outputs control the speed or variable setting of a device, such as a multi-speed fan, or a valve or damper actuator. An example is a hot water valve opening up 25% to maintain a set-point.

#### **Switch 4. Binary Input: Low voltage (Blue wire)**

A binary input indicates if a device is turned on or not. Some examples of a binary input would be a 24VDC/AC signal from an air flow switch, or a volt-free relay contact. Other examples include: high or low pressure switch, high temperature safety, thermostat, damper end switch, dirty filter switch, fan proving switch, time clock.

#### **Switch 5. Binary Input: Low voltage (Yellow wire)**

This input has the same features as the Switch 4 Binary Input.

**Note:** When both Switch 4 and Switch 5 are enabled, CSM identifies the Switch 4 interface as BI1, and the Switch 5 interface as BI2.

#### **Switch 6. Input: 0-10V analog, multistate**

Analog inputs are used to read a variable measurement.

Typical analog devices include a high or low pressure monitor, temperature, humidity or pressure sensor, thermistor, 4-20 mA, 0-10 volt or platinum resistance thermometer (resistance temperature detector), suction or discharge pressure transducer, supply air temperature thermistor, supply static pressure sensor, building pressure sensor, room temperature thermistor.

#### **All disabled.**

When all switches are Off, the WGA100 is in Range Extender mode. It joins a ZigBee network and acts as a wireless repeater to increase the wireless network range and/or improve reliability. Inputs and outputs are disabled.

### ④ Wiring

Line voltage wiring connects to the electrical supply circuit. The Black (Hot) flying lead and the Red (Switched Load) flying lead are 14AWG. The White (Neutral) flying lead is 18AWG.

Low voltage 22AWG flying leads provide connections to supply low voltage power and carry control and monitoring signals to and from low voltage input and output devices such as a fan controller, humidity sensor, setback thermostat, etc.

After joining the wireless network, the control signals from the low voltage devices pass through the WGA100 and are sent wirelessly to the ControlScope network. Depending on the zone and device configuration in the CSM, wireless signals from the WAC to the WGA100 determine the operation of the devices connected to it.

Fig. 3: Wiring Identification

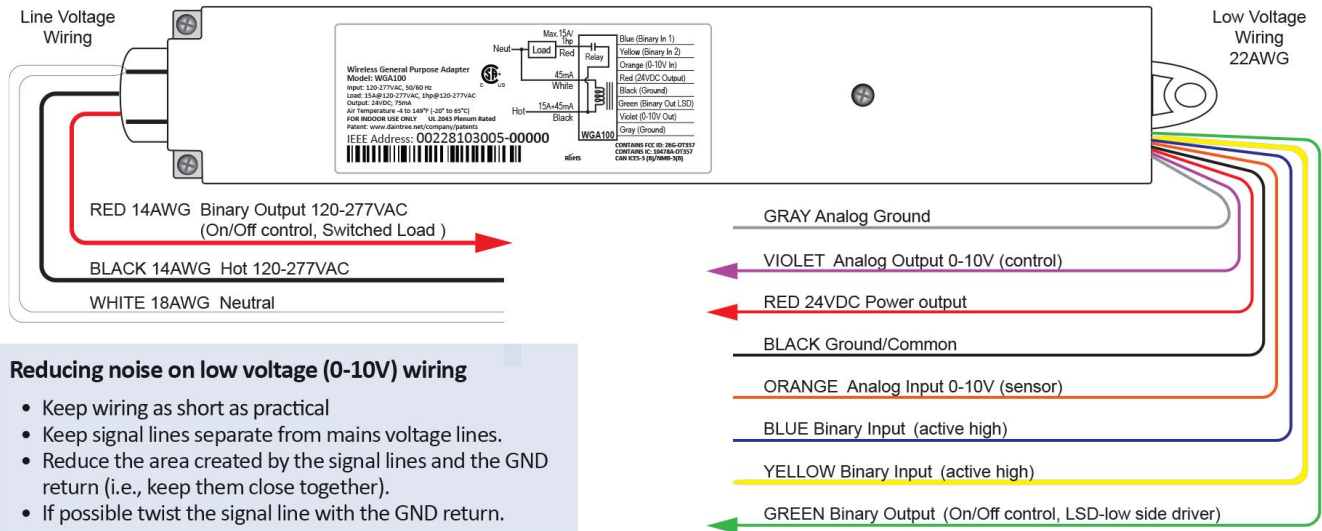

**CAUTION: Risk of electrical shock**

- Disconnect all power before installation and during servicing. Do not open WGA100 enclosure; no user-serviceable parts inside.
- All installation and maintenance of line voltage equipment must be performed by a qualified electrician.
- The WGA100 must be installed in accordance with all local, state, and national electrical codes or Canadian Electrical Code, Part 1, and in a manner acceptable to the local authority having jurisdiction.
- Wiring connectors are not supplied. UL recognized wiring connectors must be used in the installation.

Fig. 4: Switched Line Voltage Load Relay (Binary Output, DIP Switch 1 On)

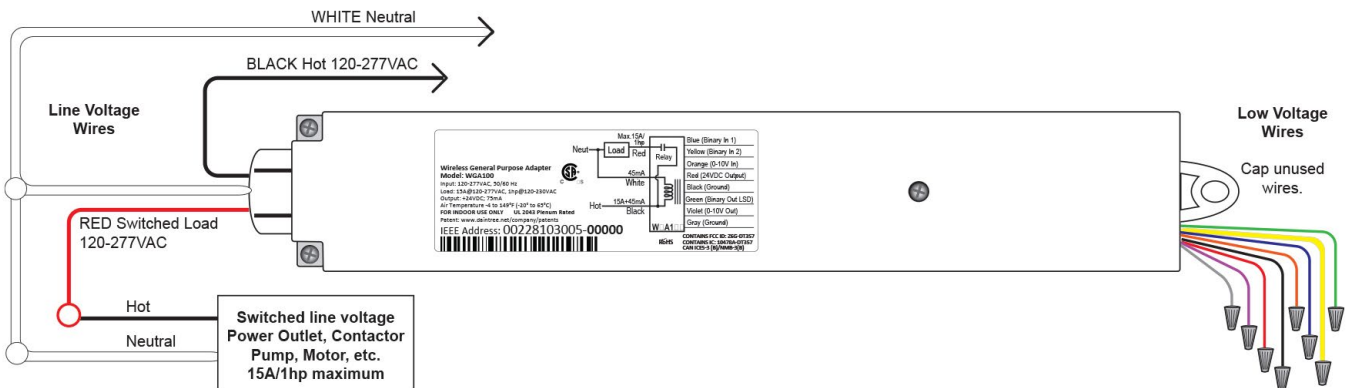

Fig. 5: Switched Line Voltage to Contactor (Binary Output, DIP Switch 1 On)

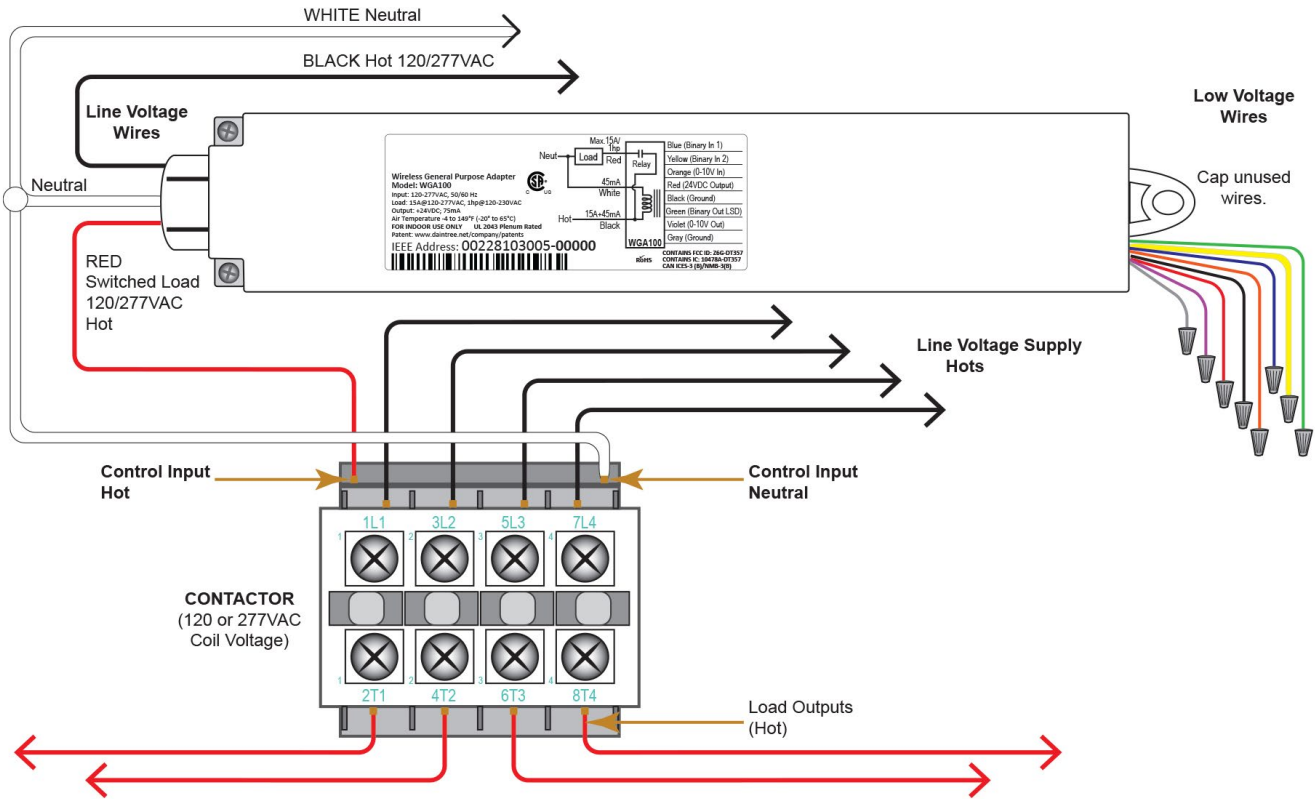

Fig. 6: Low Voltage On/Off, LSD (Binary Output, DIP Switch 2 On)

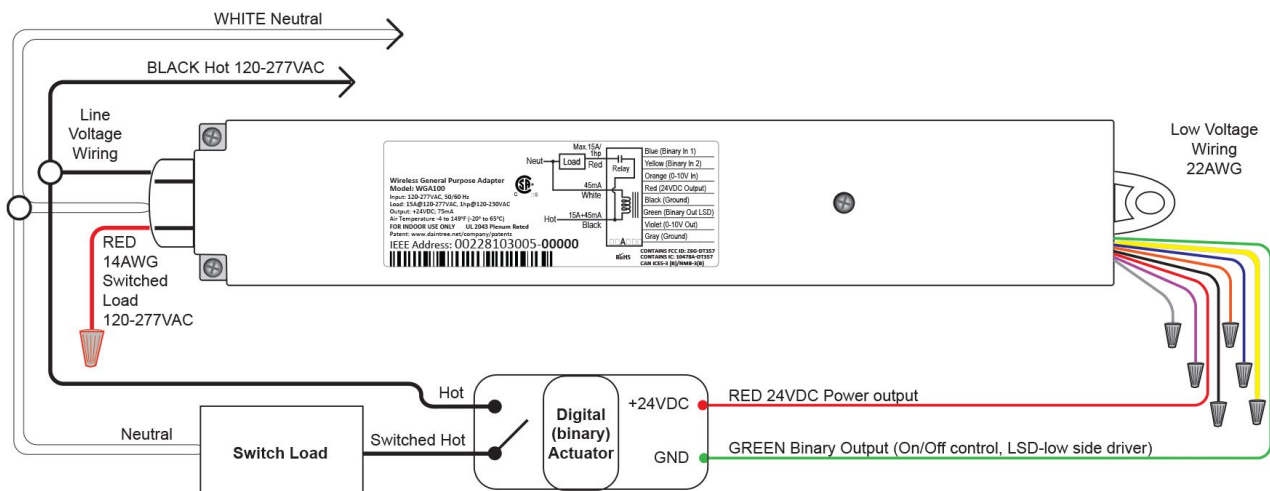

Fig. 7: Setback Thermostat (Binary Output, DIP Switch 2 On)

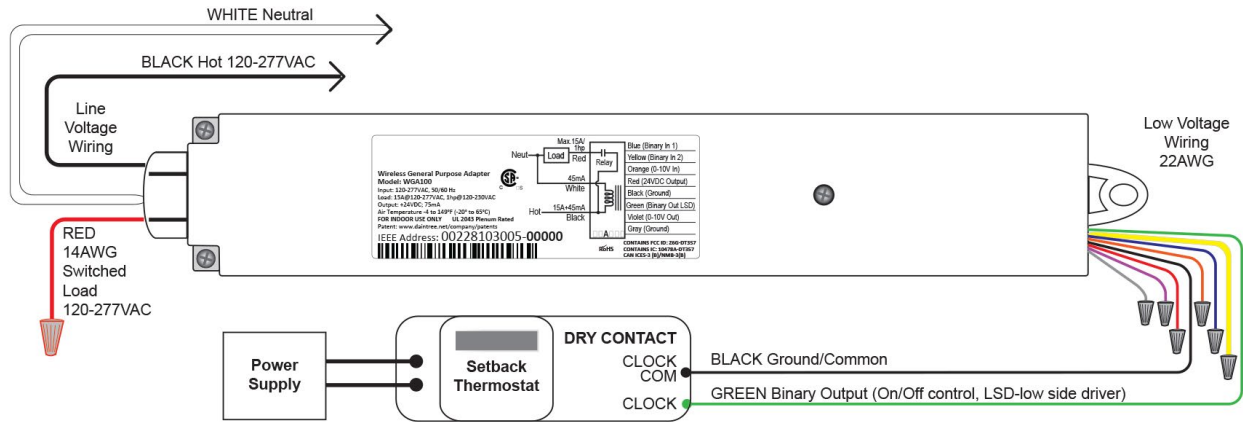

Fig. 8: Analog Output 0-10V, level controllable, multistate (DIP Switch 3 On)

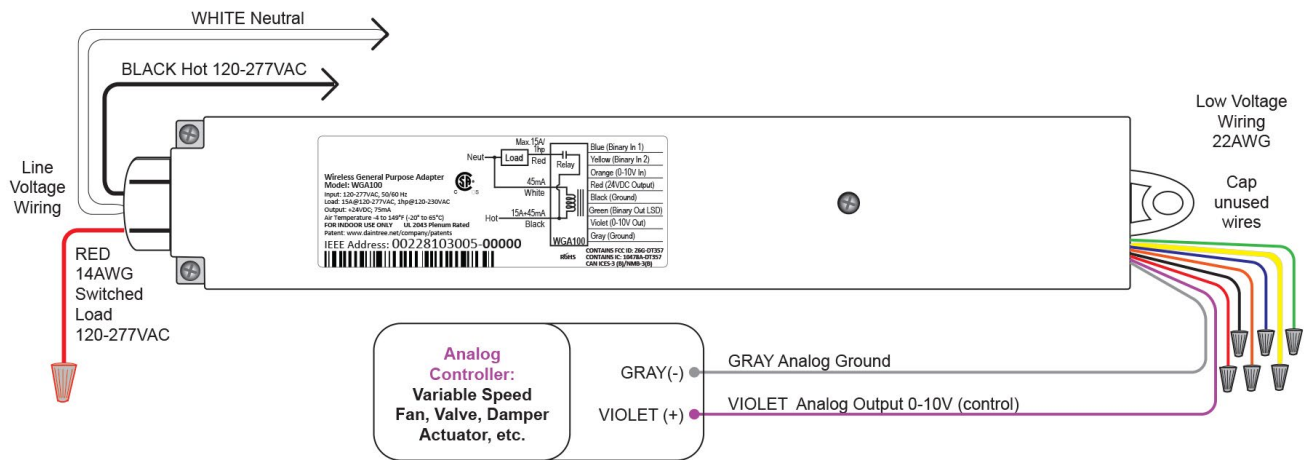

Fig. 9: Binary Input, (DIP Switch 4 or DIP Switch 5 On)

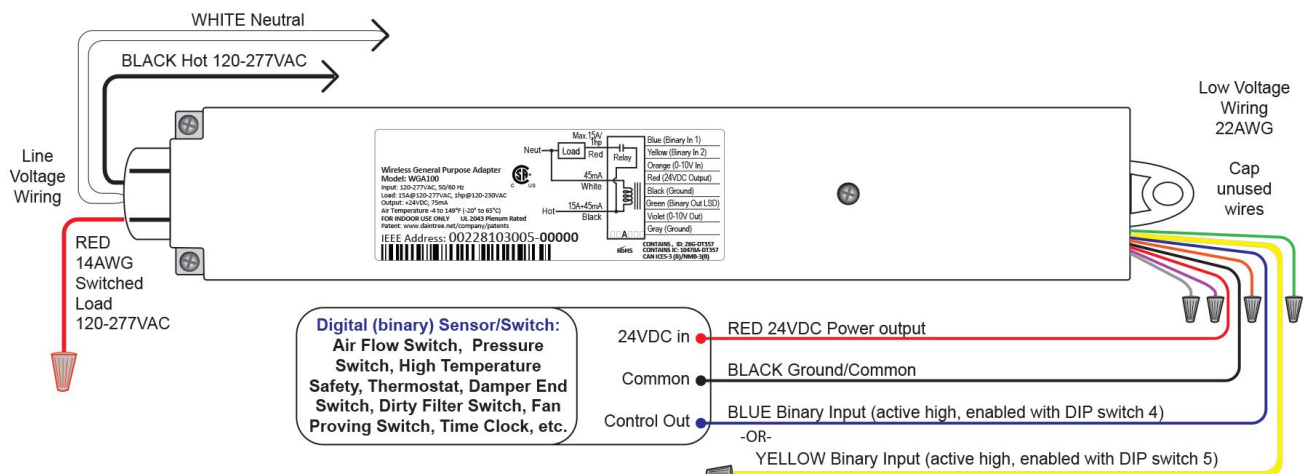

Fig. 10: Analog Input 0-10V, level monitoring, multistate (DIP Switch 6 On)

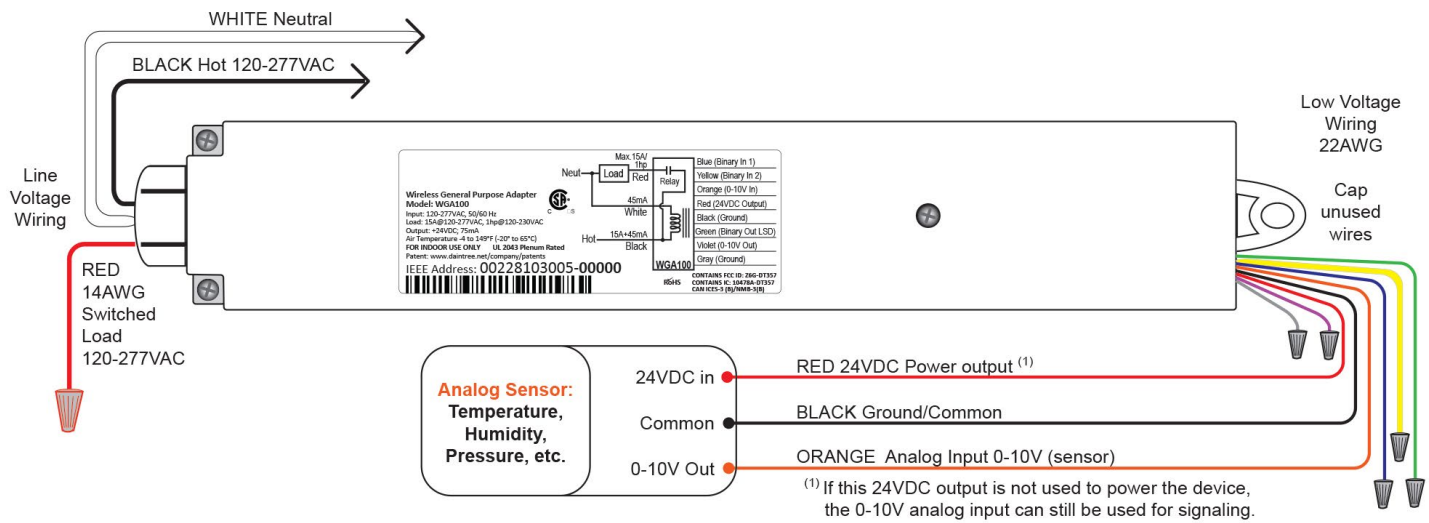
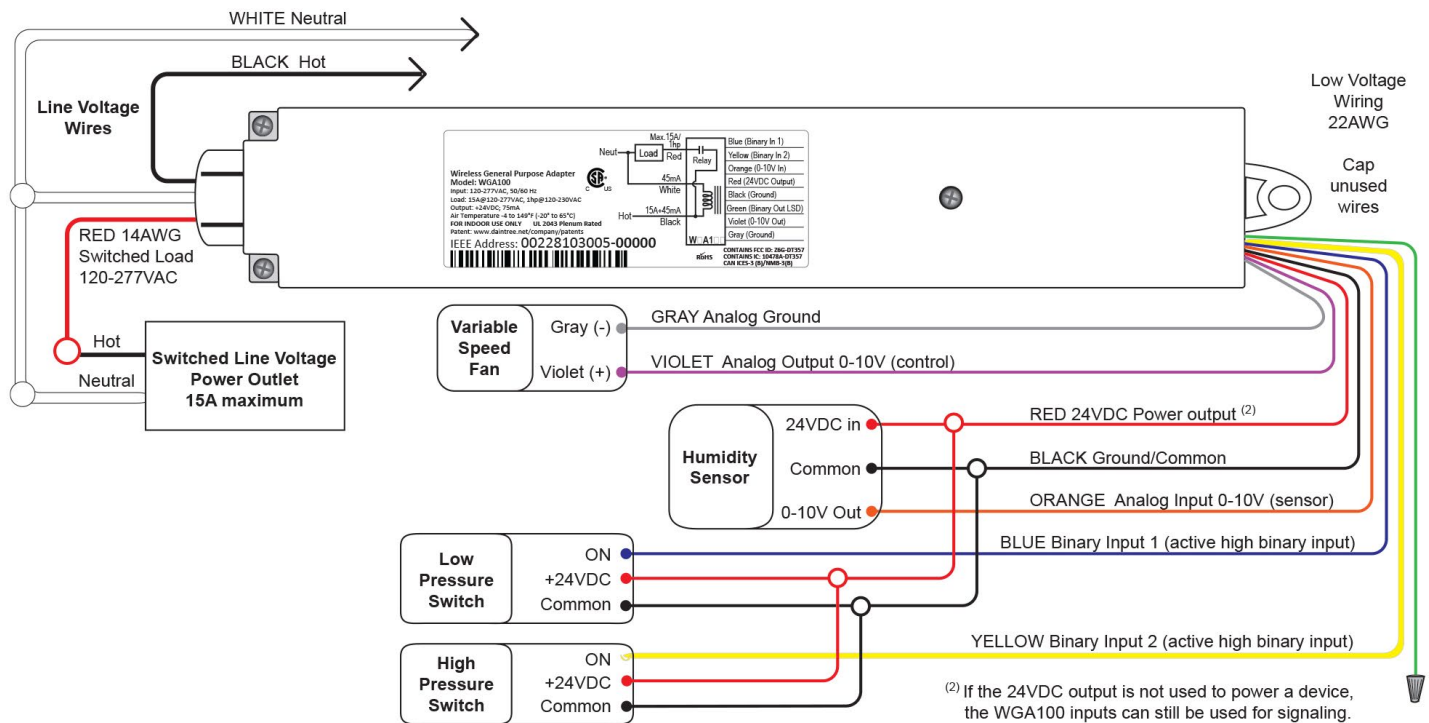

Fig. 11: Combination of Interfaces

The interfaces can be enabled in any combination. DIP Switches 1, 3, 4, 5 and 6 are turned On to enable the interfaces for the connections in the illustration below.



### 5 Mounting

The WGA100 is designed so that it can be mounted in a variety of ways.

#### Using the Mounting Bracket

The mounting bracket included with the WGA100 and shown in the illustration below provides a screw-mounting alternative. The bracket has a slot that allows wires to remain connected as you snap the bracket onto the WGA100 nipple. The WGA100 can be secured at the other end using the integral screw tab.

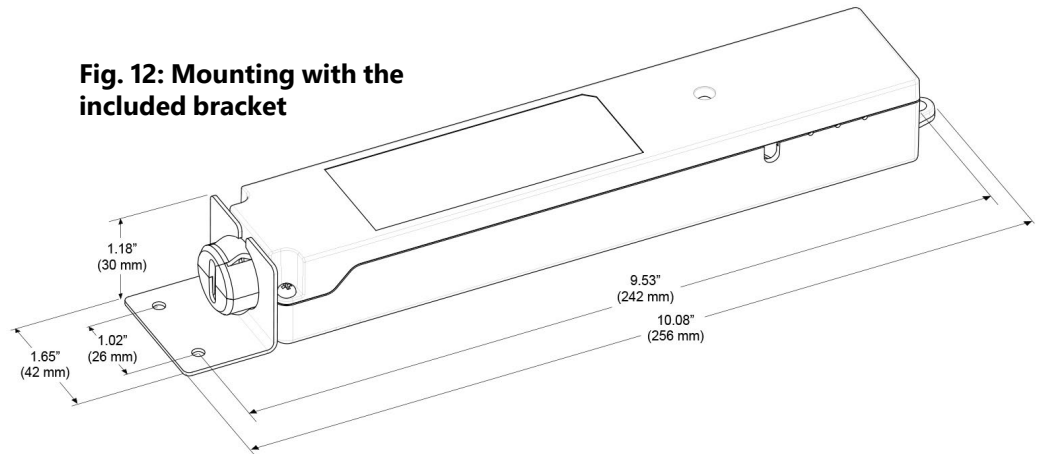

**Fig. 12: Mounting with the included bracket**

#### External to an Enclosure

Alternatively, it can be mounted externally to a junction box or enclosure through a 1/2" knockout.

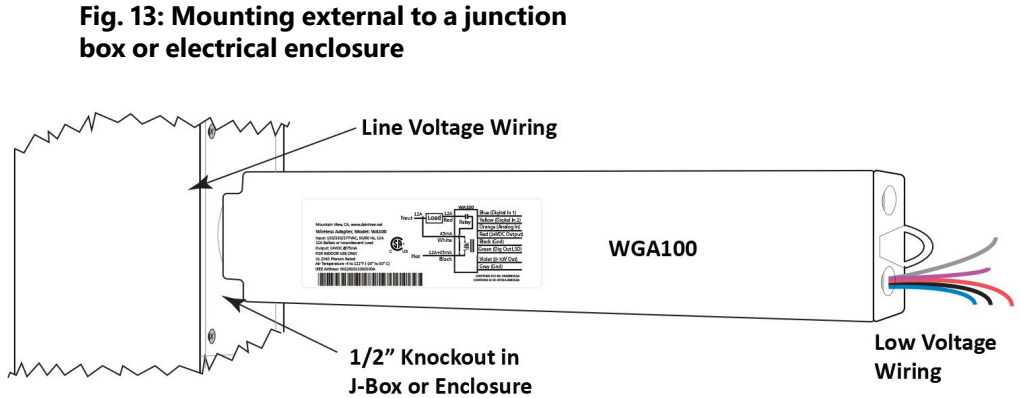

**Fig. 13: Mounting external to a junction box or electrical enclosure**

### 6 Trimming and Dressing

When the wiring connections have been decided and extra (unused) wires identified, secure the unused wires to keep them neat, out of the way, and protected against shorting or interference with other components or devices. It is best to trim unused low voltage wires to about 5 inches in length, isolate them using a wire nut or equivalent then bundle and bind them close to the adapter's body. Be sure that unused Red and Violet output wires are completely isolated from all other wires. Unused line voltage wires must be securely isolated and housed inside a junction box, or other approved electrical enclosure.

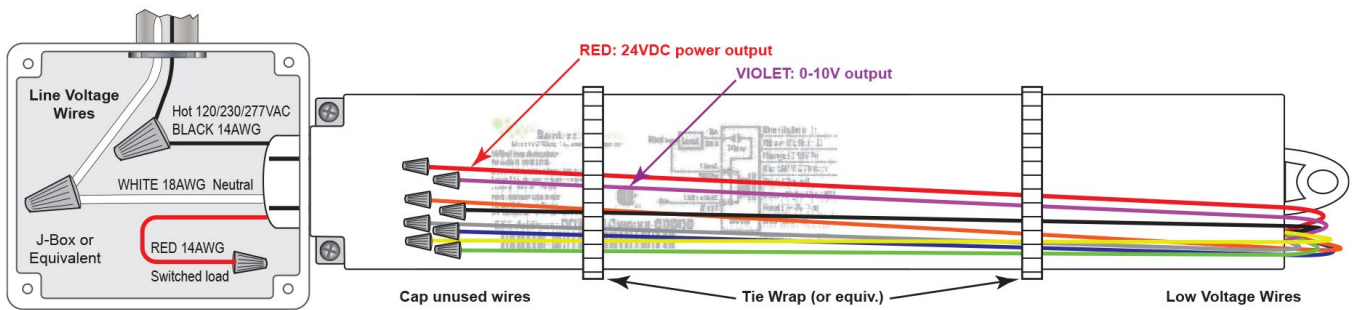



## ⑦ Installation Tests

All devices, including wireless adapters must be tested for proper operation.

After setting the DIP switches for your application, mounting, wiring low voltage, wiring line voltage, powering up and resetting the unit, perform the Installation Test. The Installation Test mode automatically times out after 5 minutes of no activity.

### Complete Installation Tests

Successful commissioning is dependent on testing each wireless-adapted device at the time of installation. Finding installation issues or device problems earlier saves significant time during the commissioning process.

## ⑧ WGA100 Installation Test Mode

To enable the WGA100 test mode, press the blue reset button once.

The test mode sequentially tests each enabled device (DIP switches that are ON).

If the device is not enabled (DIP switch is off), the system simply moves on to the next enabled device.

To exit testing, press and immediately release the reset button. You may need to do this several times to cycle through the remaining enabled device tests.

### Record IEEE Addresses

If you have not already done so, be sure that each wireless adapter's IEEE address (last 4 or 5 digits) is recorded on the facility floor plan. You can use the 4 or 5 digit "Plan" label supplied with the WGA100 or you can write the last 4 or 5 digits on the floor plan. This information will be used during the commissioning process.

After the installation is complete, a marked-up copy of the facility floor plan showing the identity and location of each wireless adapter (including associated devices) should be available. This will simplify and expedite the commissioning process.

## ⑨ Joining the ZigBee Lighting Control Network

After the Installation Test is complete the WGA100 is ready to communicate with the Daintree Wireless Area Controller (WAC) and the Daintree ControlScope Manager (CSM) web-based user interface. Upon commissioning, the WGA100 "Join" LED turns on solid and remains on as long as the WGA100 is included in the ZigBee Network.

After joining the network, the control signals to and from the low voltage devices pass through the WGA100 and are sent wirelessly to the ControlScope network. Depending on the zone and device configuration in the CSM, wireless signals from the WAC to the WGA100 determine the operation of the associated devices.

For more information about configuring the lighting control network, see the instructions and online help provided with the ControlScope Manager application.

DIP Switch Enabled	Purpose	Expected Test Mode Response
1	Switched Line voltage relay control Binary Output	Relay output toggles on and off every 30 seconds for as long as the test mode is active. Press the reset button once to move on to the next enabled device.
2	Binary Output	Binary output toggles on and off every 30 seconds for as long as the test mode is active. Press the reset button once to move on to the next device.
3	Analog (Multistate) Output	This device is not tested, regardless of whether it is enabled or not.
4	Binary Input (blue wire)	If the binary input is high, the 'joined' led on the WGA turns on. Otherwise, it stays off. Press the reset button once to move on to the next device.
5	Binary Input (yellow wire)	If the binary input is high, the 'joined' led on the WGA turns on. Otherwise, it stays off. Press the reset button once to move on to the next device.
6	Analog (Multistate) Input	The 'joined' led on the WGA flashes at a frequency proportional to the input voltage. Press the reset button once to exit the test mode.

## ⑩ Troubleshooting

The Installation Test procedure fails.

1. Confirm that the WGA100 is powered.
2. Check the connections from the WGA100 to the devices.
3. Check to be sure the WGA100 DIP switch settings are correct.
4. Press and hold the Reset button for 3 seconds to reset the WGA100.
5. Perform the Installation Test again.

## ⑪ Class A Digital Device (CE)

### Warning

This is a class A product. In domestic environments this product may cause radio interference in which case the user may be required to take adequate measures.

## 12 Troubleshooting

This equipment has been tested and found to comply with the limits for a Class B digital device, pursuant to Part 15 of the FCC Rules. These limits are designed to provide reasonable protection against harmful interference in a residential installation. This equipment generates, uses and radiates radio frequency energy and, if not installed and used in accordance with the instructions, may cause harmful interference to radio communications. However, there is no guarantee that interference will not occur in a particular installation. If this equipment does cause harmful interference to radio or television reception, which can be determined by turning the equipment off and on, the user is encourage to try to correct the interference by one or more of the following measures:

- Reorient or relocate the receiving antenna;
- Increase the separation between the equipment and receiver;
- Connect the equipment into an outlet on a circuit different from that to which the receiver is connected;
- Consult the dealer or an experienced radio/TV technician for help.

## 13 Industry Canada (IC) Warning Message

Product complies with Part 15 of the FCC Rules. Operation is subject to the following two conditions: (1) This device may not cause harmful interference, and (2) This device must accept any interference received, including interference that may cause undesired operation. CAN ICES-005 B / NMB-005 B

## Specifications

Input voltage	120-277VAC, 50-60Hz
Switched output relay	15A @ 120-277 VAC 1 hp @ 120-230 VAC
Low voltage output	24VDC @ 75mA maximum
Analog output	0-10VDC, 5mA max
Analog input	0-10VDC
Binary inputs (2)	Active high
Binary output	LSD (low side driver) aux relay control, 75mA maximum (including attached sensors)
Radio properties	2.4 GHz, +8 dBm, Range dependent on RF propagation variables such as metal obstacles
Operating environment	Indoor, dry location -4° to 149°F (-20° to 65°C)
Compliance	CSA certified, plenum rated, FCC Part 15, CA IC
Mounting	½" knockout, screw tab, optional mounting bracket supplied
Dimensions	9.4" L x 1.7" W x 1.18" H 10.1" L x 1.7" W x 1.18" H with mounting bracket
Low Voltage Wiring	Max. recommended length of up to 100' (30m)

## Questions:

**Web:** [products.gecurrent.com](http://products.gecurrent.com)

**Phone:** 1-866-855-8629

These instructions do not purport to cover all details or variations in equipment nor to provide for every possible contingency to be met in connection with installation, operation or maintenance. Should further information be desired or should particular problems arise which are not covered sufficiently for the purchaser's purposes, the matter should be referred to Current.