

Daintree™ Wireless Fixture Adapter

(WFA100-SN)



BEFORE YOU BEGIN

Read these instructions completely and carefully.
Save these instructions for future use.



⚠ WARNING

Risk of electrical shock. Disconnect power before servicing or installing product.
Install in accordance with National Electric Code and local codes.

The Daintree Wireless Fixture Adapter (WFA100-SN) forms part of the Daintree Networked wireless controls solution for smart commercial and industrial buildings. It transmits and receives messages over the wireless ZigBee® network and controls lights.

Fixture adapters are AC powered devices that provide On/Off switching as well as 0-10V analog dimming control for ballasts and LED drivers. The WFA100-SN also provides power and signal connections for low voltage occupancy sensors and photosensors (daylight harvesters). The WFA100-SN automatically configures itself for the type of sensor(s) connected to it.

The WFA100-SN provides the wireless adaptation that enables connected devices to communicate with the rest of the wireless lighting control solution. The adapter also serves as a communication router in the ZigBee® wireless mesh network. Control signals pass between the adapter and the Wireless Area Controller in the Daintree Networked platform.

① Installation Process

1. **Disconnect power before installation.** Turn off all power to affected light fixtures by turning off circuit breakers. Confirm that power is off at all light fixtures before continuing installation.
2. **Important:** Use the provided Fixture and Plan labels to identify the wireless-adapted fixture location. Attach the **Fixture** label to the outside of the fixture. Attach the **Plan** label at the fixture location on the facility floor plan.
3. Connect low voltage wiring from the WFA100-SN to the ballast, and sensors as appropriate for your application. See **Wiring** (pages 2-7).
4. Connect line voltage wiring from the supply circuit to the WFA100-SN and from the WFA100-SN to the ballast. See **Wiring**.

⚠ CAUTION

Risk of injury. Wear safety glasses and gloves during installation and servicing.

5. Check load circuits then turn on the circuit breakers to power up the WFA100-SN. The light connected to the WFA100-SN turns On when power is initially applied (and when power is restored after a power failure).
6. Ensure the WFA100-SN green Power LED is On.
7. Press and hold the Reset button on the WFA100-SN for 3 seconds to reset it. Release the button when the green Joined LED and the red Error LEDs begin flashing.
8. Perform the installation test appropriate for your application. See **Installation Tests** (pages 9-10).

LED Indicators

	Error/Test — On when the Wireless Adapter is in an error state. Flashes to indicate unit Reset and during Installation Test Mode (red).
	Joined — On when the Wireless Adapter has joined a ZigBee® network. Flashes to indicate Reset and during sensor Installation Test Mode (green).
	Power — On when power is applied to the Wireless Adapter (green).

Figure 1: LED Indicators

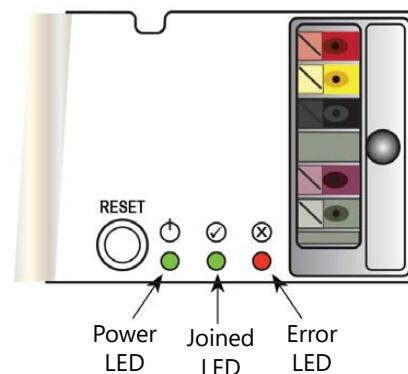

② Occupancy Sensor Time Delays

If an occupancy sensor is connected to the WFA100-SN, the time delay must be set for minimum. When Daintree Networked is commissioned, time delays are set in the Daintree DCS web application. These DCS “Off delays” start counting down after the sensor’s internal time delay expires. Therefore, set the occupancy sensor for the minimum time delay during the WFA100-SN installation.

Reducing noise on low voltage (0-10V) wiring

- Keep wiring as short as practical
- Keep signal lines separate from mains voltage lines.
- Reduce the area created by the signal lines and the GND return (i.e., keep them close together).
- If possible twist the signal line with the GND return.

③ Wiring

Line voltage wiring connects to the electrical supply circuit and to the ballast(s). Low voltage terminals provide connections for 0-10VDC dimming control signals to dimming ballasts. The WFA100-SN low voltage terminals also supply low voltage power and carry control signals from low voltage occupancy sensors and photocells.

While the WFA100-SN is in Installation Test mode, the low voltage devices directly control the lights wired to the same WFA100-SN. After you exit Installation Test mode, the lights turn On and are NOT controlled by the devices connected to the WFA100-SN.

After joining the wireless network, the control signals from the low voltage devices pass through the WFA100-SN and are sent wirelessly to Daintree Networked. Depending on the zone and device configuration in DCS, wireless signals from the WAC to the WFA100-SN determine operation of the light(s).

Design Caution

Do not install a wireless adapter such as the WFA100-SN to control an electrical circuit that provides power to other wireless devices or adapters. If power to wireless adapters or devices is shut off, control and communication with them is disabled.

Figure 2: WFA100-SN Features



Must be installed inside a light fixture, or in an enclosure to protect people from high voltage.

Figure 3: WFA100-SN Terminals



⚠ CAUTION

Risk of electrical shock. Disconnect all power before installation. All installation and maintenance of line voltage equipment must be performed by a qualified electrician. The WFA100-SN must be installed in accordance with all local, state, and national electrical codes and requirements. Wiring connectors are not supplied. UL recognized wiring connectors must be used in the installation. Each terminal can accept one conductor only. Connect only one 4AWG to 16AWG (0.2-1.5 mm) wire to any terminal.

CLASS 2 WIRING:

All field wiring shall be suitable for Class 1. Electric Light and Power, or Class 2, 3 wirings are routed separately and secured to maintain separation between:

1. Class 2 wiring and all other class wiring, and
2. Limited energy circuit conductors from unlimited energy circuit conductors.

③ Wiring Continued

Remove the jumper from the violet and pink terminals before connecting the 0-10V dimming control wires.

Figure 4: Dimming Ballasts

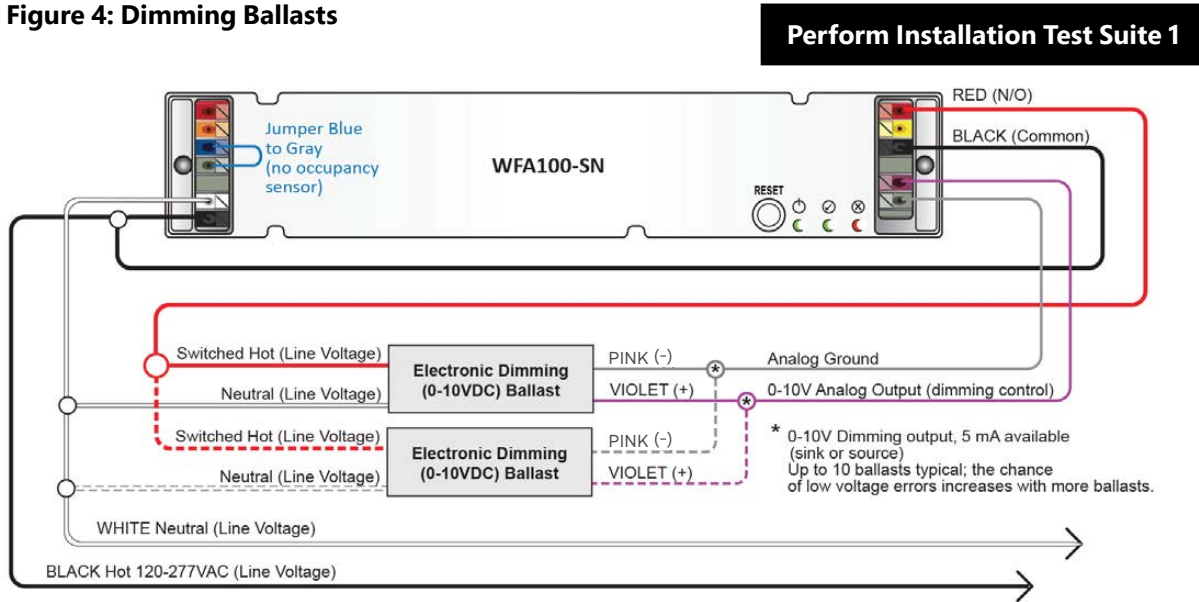
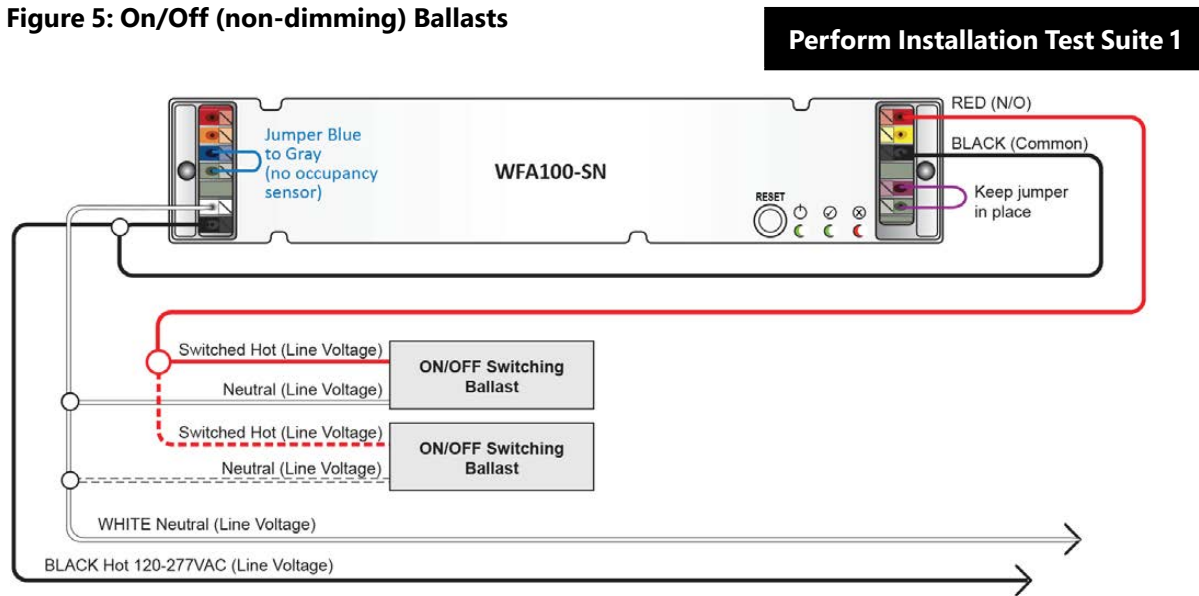

Figure 5: On/Off (non-dimming) Ballasts



③ Wiring Continued

This configuration allows the WFA100-SN to provide automatic On/Off switching of ballasts and provides an occupancy sensor input. Set the occupancy sensor for the minimum time delay.

Figure 6: On/Off (non-dimming) Ballast(s), Occupancy Sensor Configuration

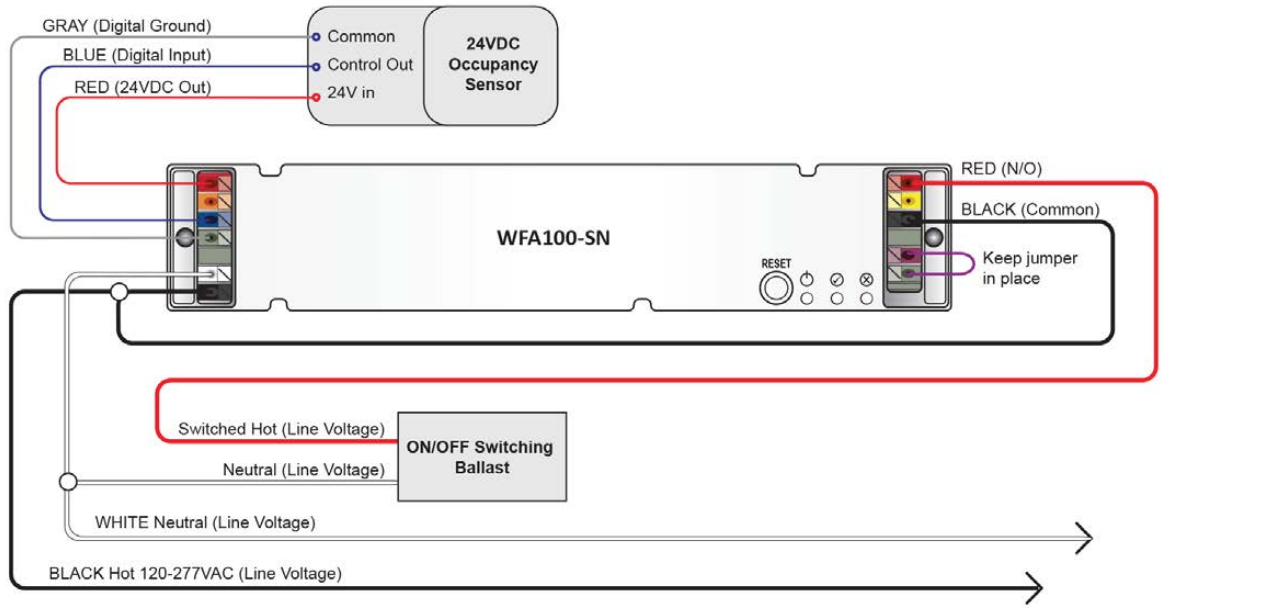

This configuration allows the WFA100-SN to provide automatic 0-10V dimming control and to switch ballasts On/Off. It also provides an occupancy sensor input. Set occupancy sensor for minimum time delay. **Remove the jumper from the violet and pink terminals before connecting the 0-10V dimming control wires. Remove the jumper from the blue and gray terminals before connecting the occupancy sensor wires.**

Figure 7: Dimming Ballast(s), Occupancy Sensor Configuration

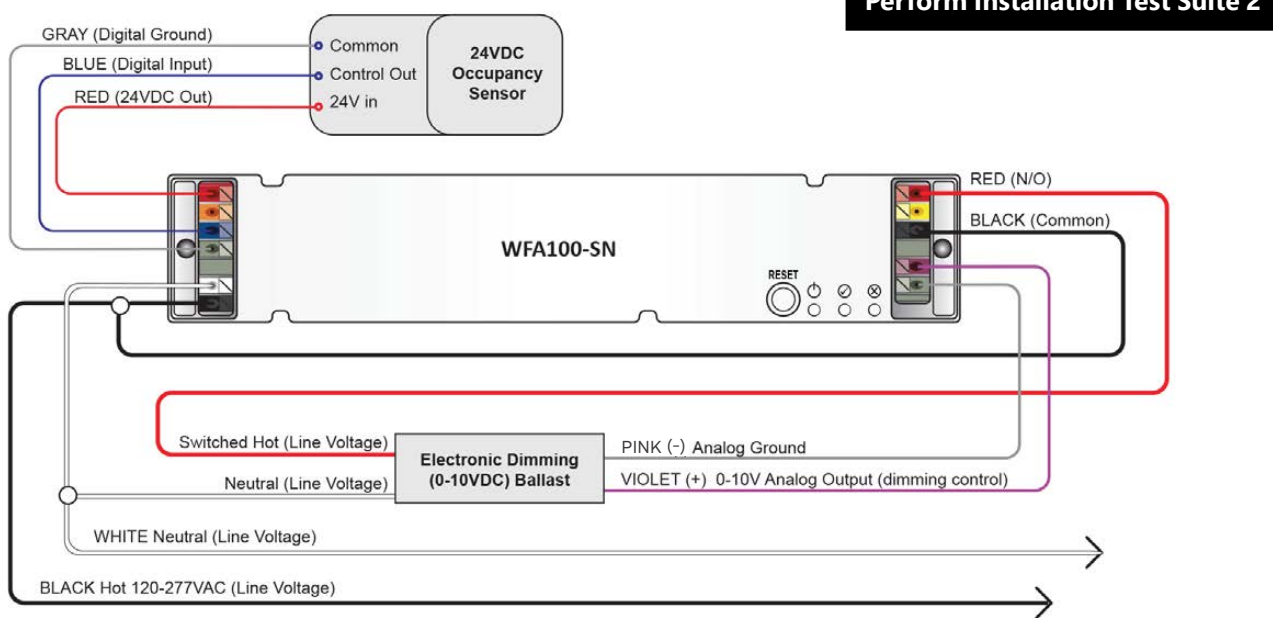

③ Wiring Continued

This configuration allows the WFA100-SN to provide automatic 0-10V dimming control and to switch ballasts On/Off. It also provides an analog photosensor input (0-10V). **Remove the jumper from the violet and pink terminals before connecting the 0-10V dimming control wires.**

Figure 8: Dimming Ballast(s), Photosensor Configuration

Perform Installation Test Suite 3

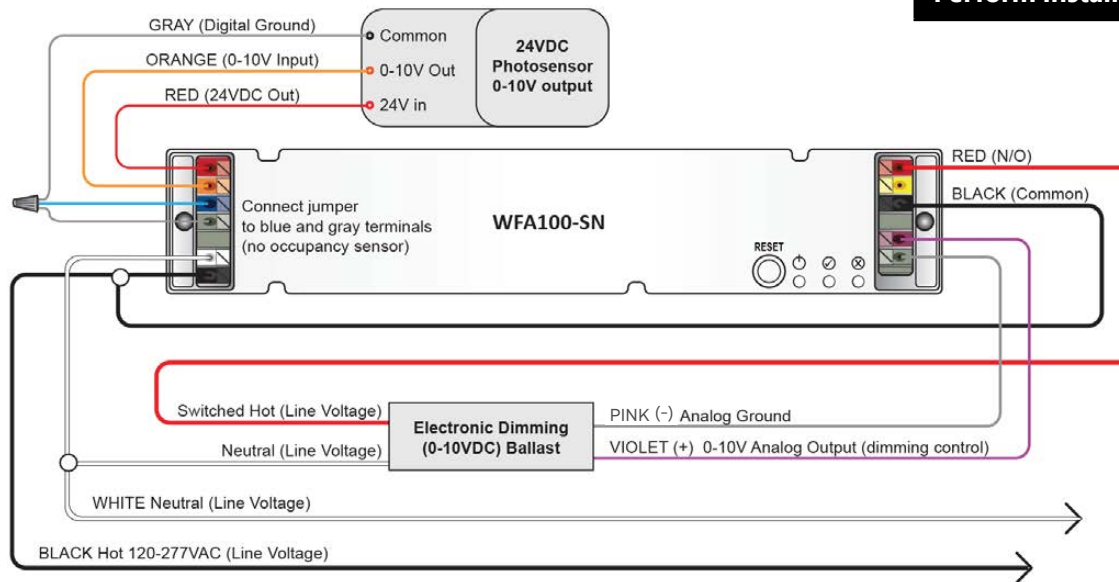

This configuration allows the WFA100-SN to provide automatic 0-10V dimming control and to switch ballasts On/Off. It also provides an occupancy sensor input. Set occupancy sensor for minimum time delay. **Remove the jumper from the violet and pink terminals before connecting the 0-10V dimming control wires. Remove the jumper from the blue and gray terminals before connecting the occupancy sensor wires.**

Figure 9: Dimming Ballast(s), Photosensor, Occupancy Sensor Configuration

Perform Installation Test Suite 4

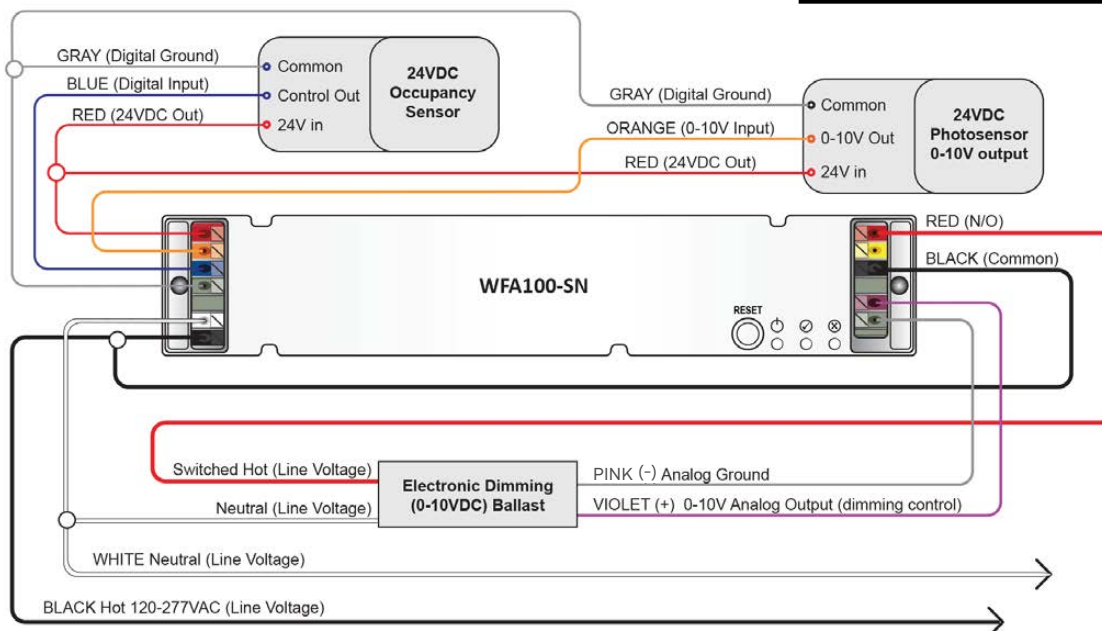

③ Wiring Continued

In the wiring diagram below, the WFA100-SN is powered by the Emergency power circuit.

Regular power is brought into the fixture from an adjacent fixture and connects to the RRU-X-UM.

While Regular power is supplied to the RRU-X-UM the WFA100-SN provides switched On/Off power to the fixture and controls dimming.

When the RRU-X-UM senses loss of Regular power, it passes Emergency power directly to the fixture and disconnects the WFA100-SN switched output. Loss of Regular power to the RRU-X-UM disables the WFA100-SN dimming control and the fixture will operate at maximum output.

Figure 10: Bypass WFA100 switched power and 0-10V dimming control during power failure

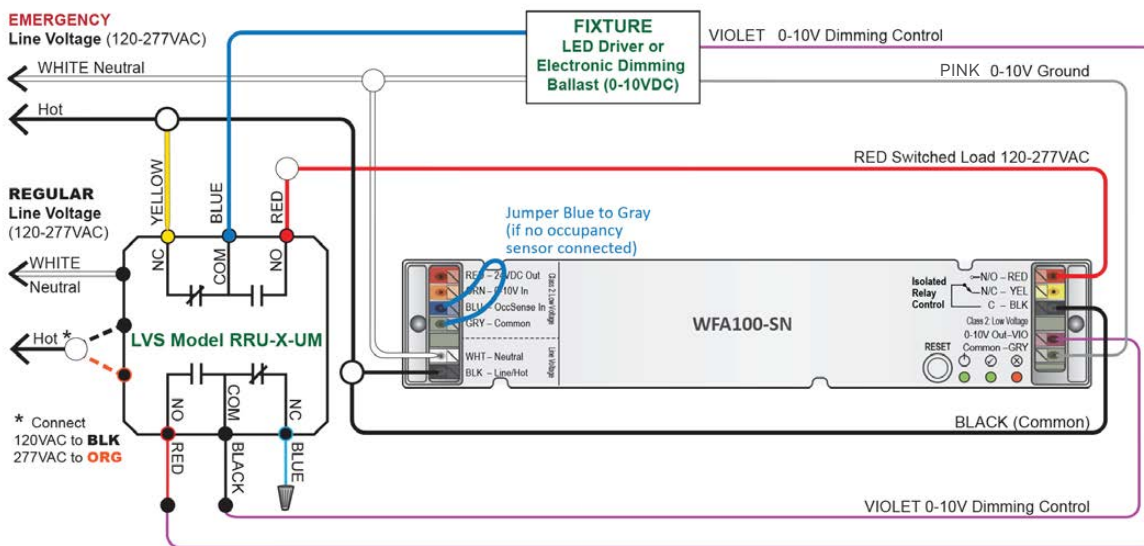

③ Wiring Continued

In the wiring diagram below, the WFA100-SN is powered by the Regular power circuit and is installed inside the Regular Fixture.

While Regular power is supplied to the RRU-2, the WFA100-SN provides switched On/Off power to the Regular Fixture ballast. The WFA100-SN also controls dimming to the Regular Fixture and the Emergency Fixture. The Emergency Fixture is powered by the Emergency power circuit.

The 0-10V dimming circuit from the WFA100-SN is brought into the Emergency Fixture.

When the RRU-2 senses loss of Regular power, the RRU-2 disconnects the 0-10V output from the WFA100-SN and the ballast will operate at maximum output from the Emergency power circuit. (If the RRU-2 is not installed, the Emergency Fixture will dim to minimum because the WFA100-SN 0-10V output shorts when the adapter loses power.)

Figure 11: Emergency Fixture and Regular Fixture: Wiring to Dim while Regular Power is Available

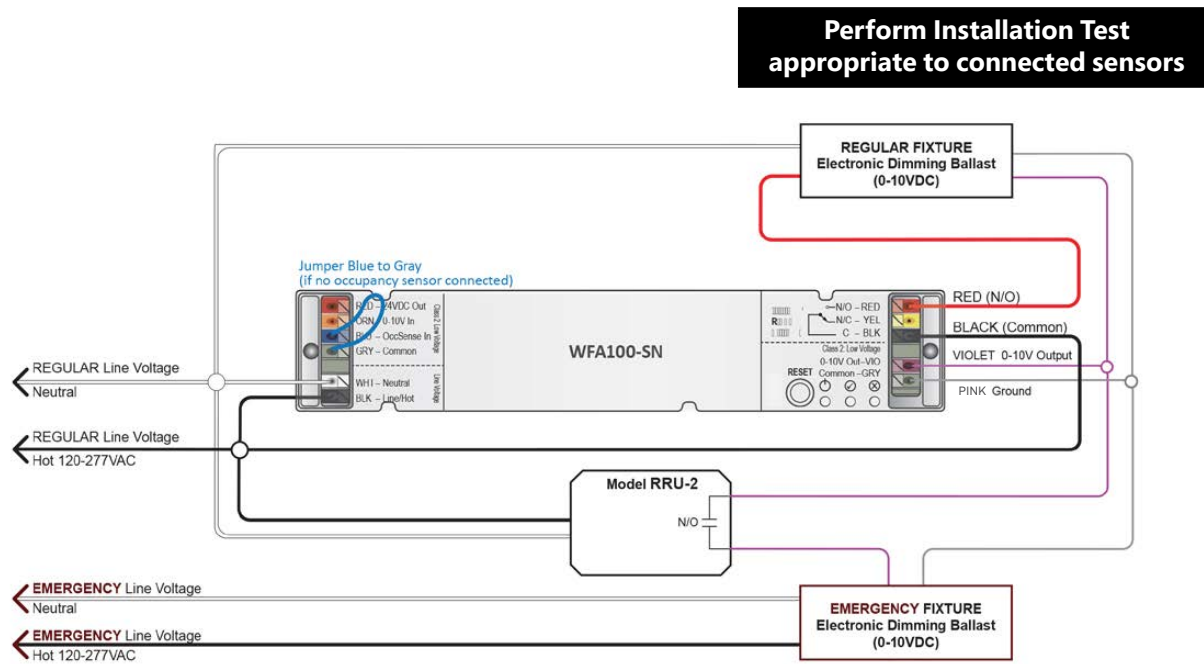

④ Mounting

The WFA100-SN is designed to be mounted inside a light fixture. Typically, it is mounted in the ballast channel using two screws.

A bar code label with the WFA100-SN’s full IEEE address on it is included with the WFA100-SN. This is the Fixture label. Affix this label to the outside of the fixture.

Choose a standard location so that when someone looks for fixtures containing an adapter, they will know where to look for the IEEE address bar code label.

Figure 12: Mounting in ballast channel

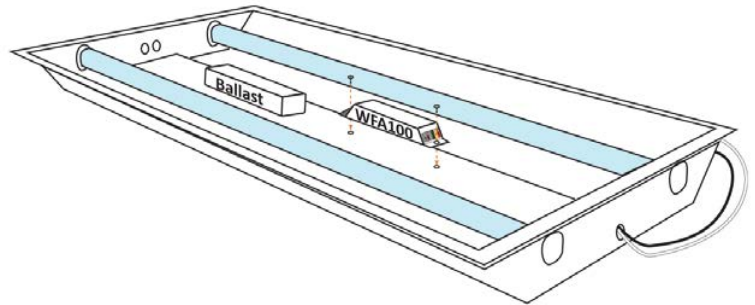
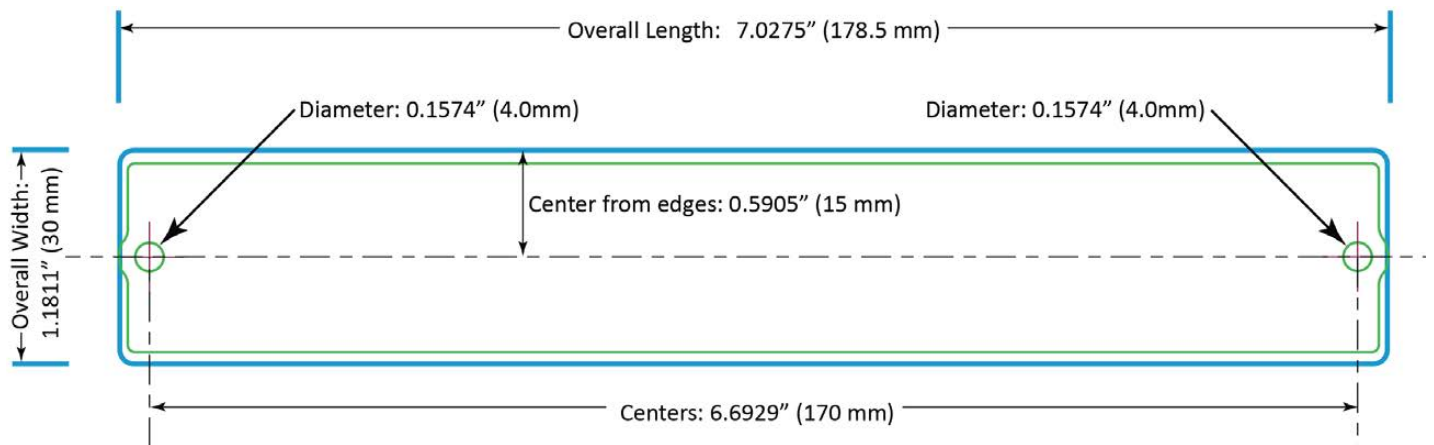

Figure 13: Mounting Template (observe measurements, illustration may not be actual size).



Important Notices

Complete Installation Tests

Successful commissioning is dependent on testing each wireless-adapted lighting fixture and control device at the time of installation. Finding installation issues or device problems earlier saves significant time during the commissioning process.

Record IEEE Addresses

If you have not already done so, be sure that each adapter’s IEEE address (last 4 or 5 digits) is recorded on the facility floor plan. You can use the 4 or 5 digit Plan label supplied with the adapter or you can write the last 4 or 5 digits on the floor plan. This information will be used during the commissioning process. After the system installation is complete, a marked-up copy of the facility floor plan showing the identity and location of each wireless adapter (including associated sensors) should be available. This will simplify and expedite the commissioning process.

⑤ Installation Tests



All lighting devices, including wireless adapters must be tested for proper operation.

After mounting, wiring low voltage, wiring line voltage, powering up and resetting the unit, perform the recommended Installation Test. The Installation Test mode automatically times out after 5 minutes of no activity.

While the WFA100-SN is in Installation Test mode, the low voltage devices connected to the WFA100-SN directly control the lights wired to the same WFA100-SN. After you exit Installation Test mode, the lights turn On and are NOT controlled by the devices connected to the WFA100-SN. After commissioning the Daintree Networked, lighting control is determined by configuration settings in the Daintree Controls Software.



Test Suite 1:

Dimming or ON/Off Ballasts Only

1. Press and immediately release the Reset button. The red Error LED flashes once, then pauses and repeats.
2. Check that the connected lights cycle On and Off, or cycle from maximum to minimum brightness then turn Off, then repeat cycle.
3. Press and immediately release the Reset button to exit testing.
4. Press and hold the Reset button on the WFA100-SN for 3 seconds to reset it. Release the button when the green Joined  LED and the red Error  LEDs begin flashing.



Test Suite 2:

Dimming or ON/Off Ballasts Only

1. Press and immediately release the Reset button. The red Error LED flashes once, then pauses and repeats.
2. Check that the connected lights cycle On and Off, or cycle from maximum to minimum brightness then turn Off, then repeat cycle.
3. Press and immediately release the Reset button again. The red Error LED flashes twice, then pauses and repeats.
4. Trigger the occupancy sensor. The light connected to the ballast turns On. When the sensor times out the light turns Off.
5. Press and immediately release the Reset button to exit testing.
6. Press and hold the Reset button on the WFA100-SN for 3 seconds to reset it. Release the button when the green Joined  LED and the red Error  LEDs begin flashing.



Test Suite 3:

Dimming or ON/Off Ballasts + Photosensor

1. Press and immediately release the Reset button. The red Error LED flashes once, then pauses and repeats.
2. Check that the connected lights cycle On and Off, or cycle from maximum to minimum brightness then turn Off, then repeat cycle.
3. Press and immediately release the Reset button again. The red Error LED flashes three times, then pauses and repeats.
4. The light connected to the ballast turns On.
5. Increase the amount of light at the photosensor by shining a bright light at it. The light dims to minimum brightness, then ramps up to full brightness after 2 seconds. For switched lights, the On/Off cycle takes 3 seconds. Maintaining the bright light at the photosensor causes the dimming or On/Off cycle to repeat periodically.
6. Press and immediately release the Reset button to exit testing.
7. Press and hold the Reset button on the WFA100-SN for 3 seconds to reset it. Release the button when the green Joined  LED and the red Error  LEDs begin flashing.

Test Suite 4:

Dimming or ON/Off Ballasts + Occupancy Sensor+ Photosensor

1. Press and immediately release the Reset button. The red Error LED flashes once, then pauses and repeats.
2. Check that the connected lights cycle On and Off, or cycle from maximum to minimum brightness then turn Off, then repeat the cycle.
3. Press and immediately release the Reset button. The red Error LED flashes twice, then pauses and repeats.
4. Trigger the occupancy sensor. The green Joined LED turns On and the light connected to the ballast turns On. When the sensor times out the Joined LED and light turns Off.
5. Press and immediately release the Reset button again. The red Error LED flashes three times, then pauses and repeats.
6. The light connected to the ballast turns On.
7. Increase the amount of light at the photosensor by shining a bright light at it. The light dims to minimum brightness, then ramps up to full brightness after 2 seconds. For switched lights, the On/Off cycle takes 3 seconds. Maintaining the bright light at the photosensor causes the dimming or On/Off cycle to repeat periodically.
8. Press and immediately release the Reset button to exit testing.
9. Press and hold the Reset button on the WFA100-SN for 3 seconds to reset it. Release the button when the green Joined  LED and the red Error  LEDs begin flashing.

⑤ Installation Tests

Test Suite 5:

Occupancy Sensor Only

1. Press and immediately release the Reset button. The red Error LED flashes twice, then pauses and repeats.
2. Trigger the occupancy sensor. The green Joined LED turns On. When the sensor times out the Joined LED turns Off.
3. Press and immediately release the Reset button to exit testing.
4. Press and hold the Reset button on the WFA100-SN for 3 seconds to reset it. Release the button when the green Joined ✓ LED and the red Error ✗ LEDs begin flashing.

Test Suite 6:

Photosensor Only

1. Press and immediately release the Reset button. The red Error LED flashes twice, then pauses and repeats.
2. The green Joined LED begins to flash. Increase the amount of light at the photosensor by shining a bright light at it. The green Joined LED flashes at a faster rate.
3. Press and immediately release the Reset button to exit testing.
4. Press and hold the Reset button on the WFA100-SN for 3 seconds to reset it. Release the button when the green Joined ✓ LED and the red Error ✗ LEDs begin flashing.

Test Suite 7:

Occupancy Sensor + Photosensor

1. Press and immediately release the Reset button. The red Error LED flashes twice, then pauses and repeats.
2. Trigger the occupancy sensor. The green Joined LED turns On. When the sensor times out the Joined LED turns Off.
3. Press and immediately release the Reset button. The red Error LED flashes three times, then pauses and repeats.
4. The green Joined LED begins to flash. Increase the amount of light at the photosensor by shining a bright light at it. The green Joined LED flashes at a faster rate.
5. Press and immediately release the Reset button to exit testing.
6. Press and hold the Reset button on the WFA100-SN for 3 seconds to reset it. Release the button when the green Joined ✓ LED and the red Error ✗ LEDs begin flashing.

⑥ Joining the Zigbee Lighting Control Network

After successfully completing the Installation Test the adapter is ready to communicate with the Daintree Wireless Area Controller (WAC) and the Daintree Controls Software (DCS) web-based lighting management user interface. Upon commissioning, the adapter's "Join" LED turns on solid and remains on as long as the adapter is included in the ZigBee Network.

After joining the network, the low voltage devices connected to the adapter do not directly control the lights that are wired to the same adapter. The control signals from the low voltage devices pass through the adapter and are sent wirelessly to the Daintree Networked platform. Depending on the zone and device configuration in the DCS, wireless signals from the WAC to the adapter determine the operation of the light(s).

For more information about configuring the lighting control network, see the instructions and on-line help provided with the Daintree Controls Software web application.

⑦ Troubleshooting

The Installation Test procedure fails.

1. Confirm that the WFA100-SN is powered.
2. Check the connections from the WFA100-SN to the ballast(s) and low voltage control devices.
3. Check to be sure the factory installed jumpers on the WFA100-SN are either in place or removed as appropriate for the connected devices.

If not connected to a 0-10V dimming ballast, be sure the jumper from the Violet and Pink terminals.

If not connected to a 0-10V dimming ballast, be sure the jumper is connected between the Violet and Pink terminals.

If connected to an occupancy sensor, remove the jumper from the Blue and Gray terminals.

If not connected to an occupancy sensor, be sure the jumper is connected between the Blue and Gray terminals.

4. Press and hold the Reset button for 3 seconds to reset the adapter.
5. Perform the Installation Test again.

Connected lights do not turn Off during the occupancy sensor Installation Test.

1. Make sure the sensor is not detecting occupancy.
2. Check the occupancy sensor time delay and make sure it is set for minimum.

When the Daintree Networked is commissioned, time delays are set in the Daintree Controls Software web application. These DCS "Off delays" start counting down after the sensor's internal time delay expires. Therefore, set occupancy sensors for the minimum time delay during the WFA100-SN installation.

⑧ CE Warning Message

Sensor (occupancy and photo) wiring lengths above 3m were not considered for immunity.

⑨ FCC Warning Message

This equipment has been tested and found to comply with the limits for a Class B digital device, pursuant to Part 15 of the FCC Rules. These limits are designed to provide reasonable protection against harmful interference in a residential installation. This equipment generates, uses and radiates radio frequency energy and, if not installed and used in accordance with the instructions, may cause harmful interference to radio communications. However, there is no guarantee that interference will not occur in a particular installation. If this equipment does cause harmful interference to radio or television reception, which can be determined by turning the equipment off and on, the user is encourage to try to correct the interference by one or more of the following measures: determined by turning the equipment off and on, the user is encourage to try to correct the interference by one or more of the following measures:

- Reorient or relocate the receiving antenna;
- Increase the separation between the equipment and receiver;
- Connect the equipment into an outlet on a circuit different from that to which the receiver is connected;
- Consult the dealer or an experienced radio/TV technician for help.

Specifications	
Input Voltage	120-277 VAC 50/60Hz
Isolated Relay	N/O and N/C contacts Load: 3A@120VAC-277VAC
Load Types	Electronic Ballast, General Use
Low Voltage Output	24VDC; 35mA max
Analog Dimming Output	22AWG, 600V, UL 1015, plenum rated Max. recommended length of up to 100' (30m)
Analog Photosensor Input	0-10VDC
Analog Input	Photosensor 0-10VDC
Digital Input	Active high occupancy sensor
Radio Properties	2.4 GHz, +8 dBm, Range dependent on RF propagation variables such as metal obstacles
Operating Environment	Indoor, dry location -13° to +158°F (-25° to +70°C)
Compliance	UL, FCC Part 15, CE
Mounting	Inside fixture, or enclosure
Dimensions	1.18" W x 0.98" H x 7.03" L (30mm W x 25mm H x 178.5mm L)

* References to "ballast" include LED drivers, general use loads.

WHS100

Installation Instructions

Each terminal can accept one conductor only. Connect only one 24AWG to 16AWG (0.2 -1.5mm²) wire to any terminal locations showing normal/emergency.

WHS100

CAUTION

RISK OF EXPOSURE IF BATTERY IS REPLACED BY AN INCORRECT TYPE. DISPOSAL OF USED BATTERIES ACCORDING TO THE INSTRUCTIONS

Questions:

Web: LED.com
Phone: 1-866-855-8629

These instructions do not purport to cover all details or variations in equipment nor to provide every possible contingency to be met in connection with installation, operation or maintenance. Should further information be desired or should particular problems arise which are not covered sufficiently for the purchaser's purposes, the matter should be referred to Current.