

OPERATION

Spectron equipped units also include:

Brownout protection: Unit will automatically transfer to emergency operation upon detection of low AC power (approximately 80% of nominal line.)

Time Delay Retransfer: upon return of normal AC power, unit will remain in emergency mode for an additional 15 minutes to allow AC power to stabilize.

LED Status Indicator

A green/red LED is provided on the control panel of all models equipped with the Spectron option.

Green Operating Status LED:

The green Operating Status LED serves as both an AC power and self-test indicator. During normal operation, the green Operating Status LED will be illuminated, indicating the presence of AC power. During all automatic or manual self-test cycles, the green Operating Status LED will blink twice every second.

Red Service Alert LED:

Under normal operating conditions, the red Service Alert LED indicator will remain off. If the Spectron controller detects a malfunction, the red Service Alert LED will blink in the pattern listed on the label (this page).

Easy ID Indicators:

When battery fault occurs, "Replace Battery" indicator will illuminate. When charger fault, LED driver fault, lamp fault or load learn failure occurs, "Replace Unit" indicator will illuminate.

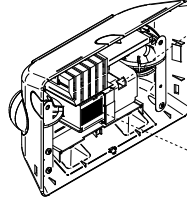

OPERATING STATUS INDICATOR:

OFF = AC OFF
GREEN ON = READY
BLINKING GREEN = TEST IN PROGRESS

SERVICE ALERT CODES:

1 RED BLINK = BATTERY DISCONNECTED
2 RED BLINKS = BATTERY FAULT
3 RED BLINKS = CHARGER FAULT
4 RED BLINKS = LED DRIVER FAULT
5 RED BLINKS = LAMP FAULT
10 RED BLINKS = LOAD LEARN FAILURE

93075193

Manual Tests

Using the unit test switch, users can initiate different duration test cycles based on the following table:

Initiating Action	Test Cycle
Press test switch once	1 minute
Press test switch twice	90 minutes

Pressing the test switch any time after a 90 minute test cycle has begun cancels the remainder of the 90 minute test and returns the unit to normal operation.

Automatic Tests

The unit will automatically initiate a self-test/self-diagnostic cycle based on the following table:

Testing Period	Duration of Test
Once a month	1 minute
Once every 6 months	Alternating: 90 minutes or 60 minutes

Service / Maintenance

Maintenance

This emergency lighting unit should be tested and maintained in accordance with National Electrical Code and NFPA 101 Life Safety Code requirements. It is recommended that emergency light fixtures be tested for 30 seconds once a month and for 90 minutes once a year.

Taking A Unit Out of Service

If a unit is to be taken out of service for an extended period, the battery harness should be disconnected from the battery compartment harness so that the battery will go into storage in a fully charged condition.

Replacing the Battery

1. De-energize the AC power
2. Open Battery Compartment cover
3. Disconnect the battery harness from the battery compartment harness.
4. Disconnect the battery strap and remove battery pack.
5. Replace with a new battery (see unit model label or battery label for correct part number) and reconnect harness.
6. Snap cover closed (tighten security screw if applicable.)

Replacing LED Lamps

The LED lamps inside the unit are not replaceable of field serviceable. Please see the Dual-Lite website for further assistance.

Troubleshooting

Emergency circuit does not work

- Batteries are shipped uncharged, please charge for 24 hours before testing.
- Make sure the switch pcb and the button/light pipe is correctly seated and aligned.
- Check wiring connections.



RECYCLING INFORMATION

All steel, aluminum and thermoplastic parts are recyclable.
NOTICE: Emergency units contain rechargeable batteries which must be recycled or disposed of properly.

93054591
93054597
93054799
93054663
93051472
93054683
93054665
93050644
93051841
93055107
93050644

93089756_A



EASY ID™

EVHC ID Series

Twin-Head LED Emergency Lighting Unit

Spectron Equipped Models

Installation, Operation, and Service Instructions



IMPORTANT SAFEGUARDS

When using electrical equipment, basic safety precautions should always be followed including the following.

READ AND FOLLOW ALL SAFETY INSTRUCTIONS

1. Do not use outdoors.
2. Do not let power supply cords touch hot surfaces.
3. Do not mount near gas or electric heaters.
4. Equipment should be mounted in locations and at heights where it will not readily be subject to tampering by unauthorized personnel.
5. The use of accessory equipment not authorized by the manufacturer may cause an unsafe condition.
6. Do not use this equipment for other than its intended purpose.
7. Servicing of this equipment should be performed by qualified service personnel.
8. Test cycling: the Life Safety Code (NFPA 101) requires testing of emergency lighting units once a month for a minimum of 30 seconds, and once a year for a minimum of 90 minutes.

INSTALLER:

- SEE UNIT LABEL FOR ADDITIONAL MODEL SPECIFICATIONS
- SAVE THESE INSTRUCTIONS FOR USE BY OWNER/OCCUPANT

WARNING – This product contains chemicals known to the State of California to cause cancer, birth defects and/or other reproductive harm. Thoroughly wash hands after installing, handling, cleaning, or otherwise touching this product.

Emergency Lighting Equipment For Use in Damp Locations

Damp location listed units are suitable for installation in:

1. Interior locations subject to moderate degrees of moisture, such as some basements, some barns, some cold storage warehouses, and the like.
2. Partially protected locations under canopies, marquees, roofed open porches and the like.

INSTALLATION

This unit is designed to be mounted on a wall. Provide Spectron® self-testing/self-diagnostic units, with a single unswitched supply from a 120 or 277 VAC branch circuit for normal lighting in the area to be protected.

The EVHC Spectron® unit is equipped with intelligent wiring. Connect the black wire from the unit to the hot building wire (120 or 277VAC) and the white wire to the building com wht wire.

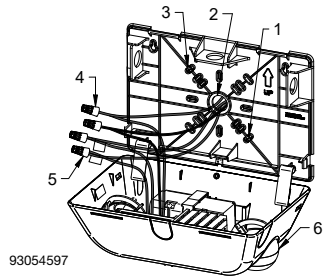

93054597

Wall Mount – Wiring

1. Remove appropriate KO's in backplate to mount backplate to junction box.
2. Remove center KO from backplate and feed supply leads through.
3. Secure back plate to junction box.
4. Connect wires from the unit to the building leads and secure with wire nuts.
5. For remote EVHC models, cut the orange connector from both remote leads and strip ends 1/2 inch. Observe proper polarity when connecting remote leads to remote fixtures. Pos. (+) to red remote fixture lead and Neg. (-) to black remote fixture lead.
6. Installer should now become familiar with the eyeball aimability and its limitations.

Wall Mount – Conduit Wiring

1. Remove appropriate KO's in back plate and mount backplate to wall.
2. Affix conduit to backplate using correct hardware. (Note: 3 mounting points)
3. Remove appropriate K.O.'s on housing.
4. Connect wires from the unit to the building leads and Secure with wire nuts.
5. For remote EVHC models, cut the orange connector from both remote leads and strip ends 1/2 inch. Observe proper polarity when connecting remote leads to remote fixtures. Pos. (+) to red remote fixture lead and Neg. (-) to black remote fixture lead.
6. Installer should now become familiar with the eyeball aimability and its limitations.

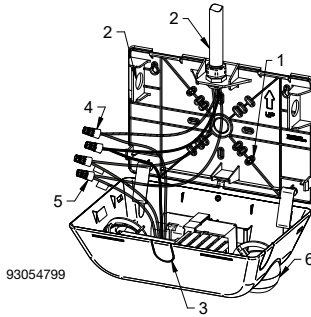

93054799

Installing the Unit: Final Assembly

1. Align housing slots over tabs on backplate.
2. Pivot housing and snap closed.
3. Aim the lamps. Do not press on the lenses.
4. Connect battery pack harness to unit battery compartment harness.

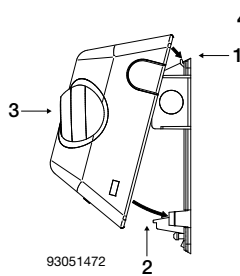

93051472

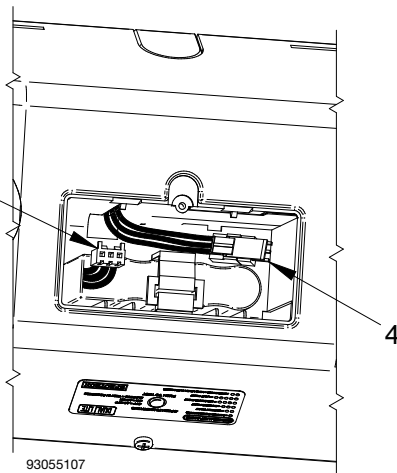

93055107

INSTALLATION

When opening battery compartment cover unscrew security screw until cover can be opened and pull open.

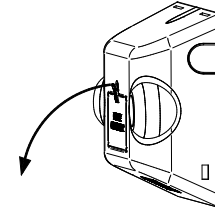

93054683

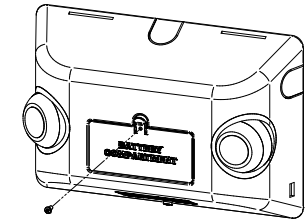

#6 Captive thread forming screw provided

93054665

OPERATION

*****Once remote capacity model EVHC ID is installed, press and hold the test button for more than 5 seconds to initiate the "LOAD LEARN" process.*****

"AC ON" LED is illuminated when AC power is present.

NOTE: All models are supplied with an AC Lockout circuit, which prevents the emergency lights from illuminating when the battery is connected and no AC power is present.

NOTE: All models are supplied with Low Voltage Disconnect circuit, which prevents damage to the battery from deep discharge during prolonged emergency operation.

NOTE: Batteries are often shipped in a discharged state – this is normal. The battery will require charging. Allow 24 hours of charging before testing the unit.

Models with SPECTRON®Self-Testing/Self-Diagnostic Circuitry

Models equipped with the Spectron® self-testing/self-diagnostic electronics system provide:

- Visual indication of AC power status
- Visual indication on self-diagnostic test status and results

Visual indication of any unit malfunctions include –

- Battery Disconnected
- Battery Fault
- Charger Fault
- LED Driver Fault
- Lamp Fault
- Load Learn Failure