

## INSTALLATION

### Installing the Unit: Final Assembly

1. Align housing slots over tabs on backplate.
2. Pivot housing and snap closed.
3. Aim the lamps. Do not press on the lenses.

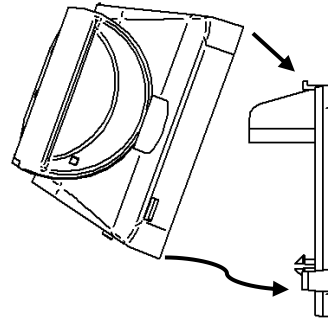

## EZ-2 Series

*Twin-Head LED Emergency Lighting Unit Standard,  
and Spectron® Equipped Models Installation,  
Operation, and Service Instructions*



## Service / Maintenance

### Maintenance

This emergency lighting unit should be tested and maintained in accordance with National Electrical Code and NFPA 101 Life Safety Code requirements. It is recommended that emergency light fixtures be tested for 30 seconds once a month and for 90 minutes once a year.

### Taking A Unit Out Of Service

If a unit is to be deliberately taken out of service for an extended period, the battery lead connector should be disconnected from the charger circuit board and insulated so that the battery will go into storage in a fully charged condition.

### Replacing the Battery

1. De-energize the AC power.
2. Disengage the Battery cover.
3. Disconnect the battery leads.
4. Remove the battery from the clips inside the cover.
5. Replace with a new battery (see unit model label for correct part number) and reconnect leads.
6. Reassemble battery cover.

### Replacing LED Lamps

The LED lamps inside the unit are not replaceable or field serviceable. Please see dual-lite.com for further assistance.

### Troubleshooting

#### Emergency circuit does not work

- Batteries are shipped uncharged and disconnected. Connect battery leads and charge 24 hours before testing.
- Make sure the charger board and test button/light pipe are properly seated and aligned.
- Check wiring connections.

## IMPORTANT SAFEGUARDS

When using electrical equipment, basic safety precautions should always be followed including the following.

## READ AND FOLLOW ALL SAFETY INSTRUCTIONS

1. Do not use outdoors.
2. Do not let power supply cords touch hot surfaces.
3. Do not mount near gas or electric heaters.
4. Equipment should be mounted in locations and at heights where it will not readily be subject to tampering by unauthorized personnel.
5. The use of accessory equipment not authorized by the manufacturer may cause an unsafe condition.
6. Do not use this equipment for other than its intended purpose.
7. Servicing of this equipment should be performed by qualified service personnel.
8. Test cycling: the Life Safety Code (NFPA 101) requires testing of emergency lighting units once a month for a minimum of 30 seconds, and once a year for a minimum of 90 minutes.

## INSTALLER:

- SEE UNIT LABEL FOR ADDITIONAL MODEL SPECIFICATIONS
- SAVE THESE INSTRUCTIONS FOR USE BY OWNER/OCCUPANT



### RECYCLING INFORMATION

All steel, aluminum and thermoplastic parts are recyclable.  
NOTICE: Emergency units contain rechargeable batteries which must be recycled or disposed of properly.

93123312

**WARNING** – This product contains chemicals known to the State of California to cause cancer, birth defects and/or other reproductive harm. Thoroughly wash hands after installing, handling, cleaning, or otherwise touching this product.

### Emergency Lighting Equipment for Use in Damp Locations

Damp location listed units are suitable for installation in:

1. Interior locations subject to moderate degrees of moisture, such as some basements, some barns, some cold storage warehouses, and the like.
2. Partially protected locations under canopies, marquees, roofed open porches and the like.

This unit is designed to be mounted on a wall or ceiling. Provide standard units with a single unswitched supply from a 120VAC, 240VAC, or 277VAC branch circuit used for normal lighting in the area to be protected. For Spectron® self-testing/self-diagnostic units, provide unit with a 120VAC or 277VAC branch circuit.

**The EZ-2 unit is equipped with intelligent wiring. Connect the black wire from the unit to the hot building wire (120-277VAC) and the white wire to the neutral building wire.**

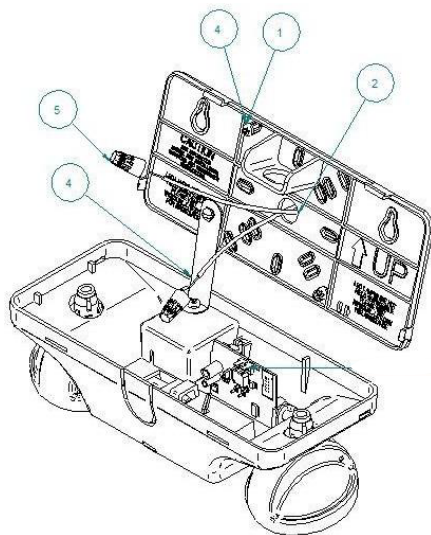

**Wall or Ceiling Mount – Back Power Feed**

1. Remove appropriate KO's in backplate to mount backplate to junction box.
2. Remove center KO from backplate and feed supply leads through.
3. Secure backplate to junction box.
4. To help with wiring, attach cover to backplate with provided plastic hinge.
5. Connect wires from the unit to the building leads and secure with wire nuts.
6. Disengage the battery cover.
7. Connect battery lead to circuit board header as shown.
8. Installer should now become familiar with the Lamp head aimability and its limitations.

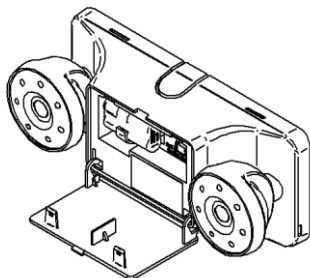

**Wall Mount – Surface Wiring (Top Power Feed Only)**

1. Remove appropriate KO's in backplate and mount backplate to wall.
2. Feed wires through and secure conduit to backplate.
3. Remove the breakout on top of the housing.
4. To help with wiring, attach cover to backplate with provided plastic hinge.
5. Connect wires from the unit to the building leads and secure with wire nuts.
6. Disengage the battery cover.
7. Connect battery lead to circuit board header as shown.
8. Installer should now become familiar with the Lamp head aimability and its limitations.

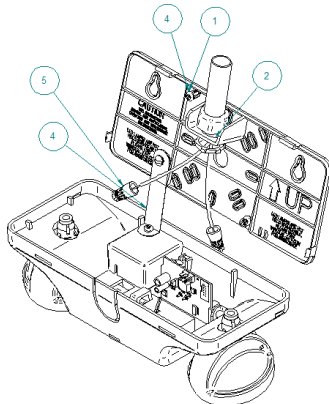

**\*\* Once the EZ-2 model is installed, press and hold the test button for more than 5 seconds to initiate the load learn process. \*\***

**Operation**

“AC ON” LED is illuminated when AC power is present.

NOTE: All models are supplied with an AC Lockout circuit, which prevents the emergency lights from illuminating when the battery is connected, and no AC power is present.

NOTE: All models are supplied with a Low Voltage Disconnect circuit, which prevents damage to the battery from deep discharge during prolonged emergency operation.

NOTE: Batteries are often shipped in a discharged state – this is normal. The battery will require charging. Allow 24 hours of charging before testing the unit.

**Models with SPECTRON® Self-Testing/Self-Diagnostic Circuitry**

Models equipped with the Spectron® self-testing/self-diagnostic electronics system provide:

- ✓ Visual indication of AC power status
- ✓ Visual indication of self-diagnostic test status and results

**Visual indication of any unit malfunctions includes:**

- ✓ Battery Disconnected
- ✓ Battery Fault
- ✓ Charger Fault
- ✓ LED Driver Fault
- ✓ Lamp Fault

Spectron equipped units also include:

Brownout protection: unit will automatically transfer to emergency operation upon detection of low AC power (approximately 80% of nominal line).  
Time Delay Retransfer: upon return of normal AC power, unit will remain in emergency mode for an additional 15 minutes to allow AC power to stabilize.

A bicolor LED (green/red) is provided on the control panel of all models equipped with the Spectron® option.

**Green Operating Status LED:**

The green Operating Status LED serves as both an AC power and self-test indicator. During normal operation, the green Operating Status LED will be illuminated, indicating the presence of AC power. During all automatic or manual self-test cycles, the green Operating Status LED will blink twice every second.

**Red Service Alert LED:**

Under normal operating conditions, the red Service Alert LED indicator will remain off. If the Spectron® controller detects a malfunction, the red Service Alert LED will blink in the pattern listed in the following table:

| Red Status LED Code   | Description           |
|-----------------------|-----------------------|
| One blink ON/pause    | Battery disconnected  |
| Two blinks ON/pause   | Battery fault         |
| Three blinks ON/pause | Charger fault         |
| Four blinks ON/pause  | LED Driver fault      |
| Five blinks ON/pause  | Lamp fault            |
| Red/Green alternating | Load Learn in Process |

**Automatic Tests**

The unit will automatically initiate a self-test/self-diagnostic cycle based on the following table:

| Testing Period      | Duration of Test                         |
|---------------------|--|
| once a month        | 1 minute                                 |
| Once every 6 months | Alternating:<br>30 minutes or 60 minutes |

**Manual Tests**

Using the unit test switch, users can initiate different duration test cycles based on the following table:

| Initiating Action       | Test Cycle |
|-------------------------|------------|
| Press test switch once  | 1 minute   |
| Press test switch twice | 90 minutes |

Pressing the test switch any time after a 90 min. test cycle has begun cancels the remainder of the 90 min. test and returns the unit to normal operation.