



LED Luminaires

Refit™ Strip Fixture Retrofit Series (RLB2 Series)



BEFORE YOU BEGIN

Read these instructions completely and carefully.



WARNING/AVERTISSEMENT

RISK OF ELECTRIC SHOCK

- Turn power off before inspection, installation or removal.
- Properly ground electrical enclosure.
- Luminaire wiring and electrical parts may be damaged when drilling for installation of LED retrofit kit. Check for enclosed wiring and components.
- LED Retrofit Kit installation requires knowledge of luminaire electrical systems. If not qualified, do not attempt installation. Contact a qualified electrician.
- Install this kit only in the luminaires that have the construction features and dimensions shown in the photographs and/or drawings and where the input rating of the retrofit kit does not exceed the input rating of the luminaire.
- To prevent wiring damage or abrasion, do not expose wiring to edges of sheet metal or other sharp objects.
- Do not make or alter any open holes in an enclosure of wiring or electrical components during kit installation.

RISK OF FIRE

- Follow all NEC and local codes.
- Use only UL approved wire for input/output connections. Minimum size 18 AWG or 14 AWG for continuous runs.

RISQUES DE DÉCHARGES ÉLECTRIQUES

- Coupez l'alimentation avant d'inspecter, installer ou déplacer le luminaire.
- Assurez-vous de correctement mettre à la terre le boîtier d'alimentation électrique.
- Le câblage du luminaire ainsi que ses composantes électriques peuvent être endommagés lors du perçage requis pour l'installation de l'ensemble de mise à niveau à DEL. Vérifiez le câblage et les composants.
- L'installation de l'ensemble de mise à niveau à DEL requiert des connaissances en système électrique d'éclairage. Si vous n'avez pas les qualifications adéquates, ne procédez pas à l'installation et contactez un électricien qualifié.
- N'installez cet ensemble de mise à niveau que dans des luminaires ayant les caractéristiques de construction et les dimensions indiquées dans les photographies et / ou dessins. La puissance d'entrée de l'ensemble de mise à niveau ne doit pas excéder la puissance d'entrée nominale du luminaire dans lequel il est installé.
- Afin de prévenir tout dommage ou abrasion aux fils électriques, évitez que ceux-ci ne viennent en contact avec les bordures métalliques ou d'autres objets pointus.
- Seules les ouvertures indiquées sur les photos et dessins peuvent être faites ou modifiées lors de l'installation de l'ensemble de mise à niveau à DEL.

RISQUES D'INCENDIE

- Respectez tous les codes NEC et codes locaux.
- N'utilisez que des fils approuvés par UL pour les entrées/ sorties de connexion. Taille minimum 18 AWG ou 14 AWG pour les rangées continues.

Save These Instructions

Use only in the manner intended by the manufacturer. If you have any questions, contact the manufacturer.

Prepare Electrical Wiring



Electrical Requirements

- Limited to use in dry locations.
- The grounding and bonding of the ballast shall be done in accordance with National Electric Code (NEC) Article 600.
- Follow all National Electric Codes (NEC) and local codes.



Grounding Instructions

- The grounding and bonding of the overall system shall be done in accordance with National Electric Code (NEC) Article 600 and local codes.

This device complies with Part 15 of the FCC Rules. Operation is subject to the following two conditions: (1) This device may not cause harmful interference, and (2) this device must accept any interference received, including interference that may cause undesired operation. CAN ICES-005 (A) / NMB-005 (A)''

This device complies with part 15 of the FCC rules for the United States and Industry Canada (IC) license exempt RSS standard(s). Operation is subject to the following two conditions: (1) This device may not cause harmful interference, and (2) this device must accept any interference received, including interference that may cause undesired operation. Any changes or modifications not expressly approved by the manufacturer could void the user's authority to operate this equipment. This product is intended for commercial use only.

NOTE: This equipment has been tested and found to comply with the limits for a Class A digital device, pursuant to part 15 of the FCC Rules. These limits are designed to provide reasonable protection against harmful interference when the equipment is operated in a commercial environment. This equipment generate, uses, and can radiate radio frequency energy and, if not installed and used in accordance with the instruction manual, may cause harmful interference to radio communications. Operation of this equipment in a residential area is likely to cause harmful interference in which case the user will be required to correct the interference at his own expense.

Installation

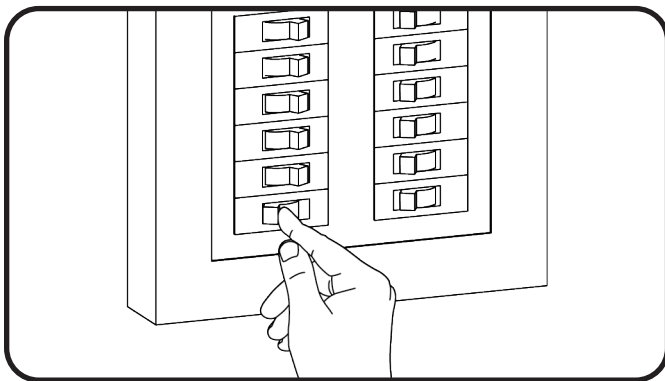

- 1 PRIOR TO INSTALLATION:** Turn off power to fixture.

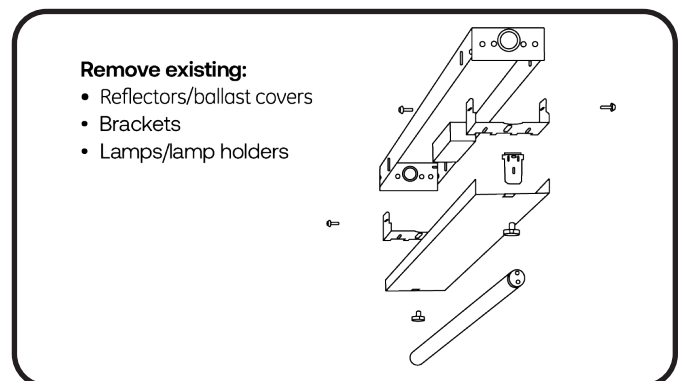

- 2 PREPARE EXISTING FIXTURE FOR INSTALLATION:** Remove all electrical parts and ballast compartment cover leaving only the supply and gr ounding leads.

NOTE: Please properly dispose of lamps and removed components.

Installation - Continued

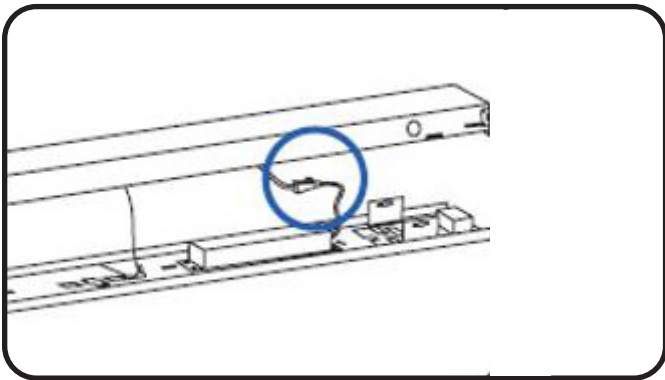

3 CONNECT DRIVER TO MAIN FEED

NOTE: For sensor SKUs, **Please ensure the sensor is properly secured** prior to installing the LED panel.

CAUTION: For sensor SKUs, Please be careful with handling. Keep hand far from sensor location while installing.

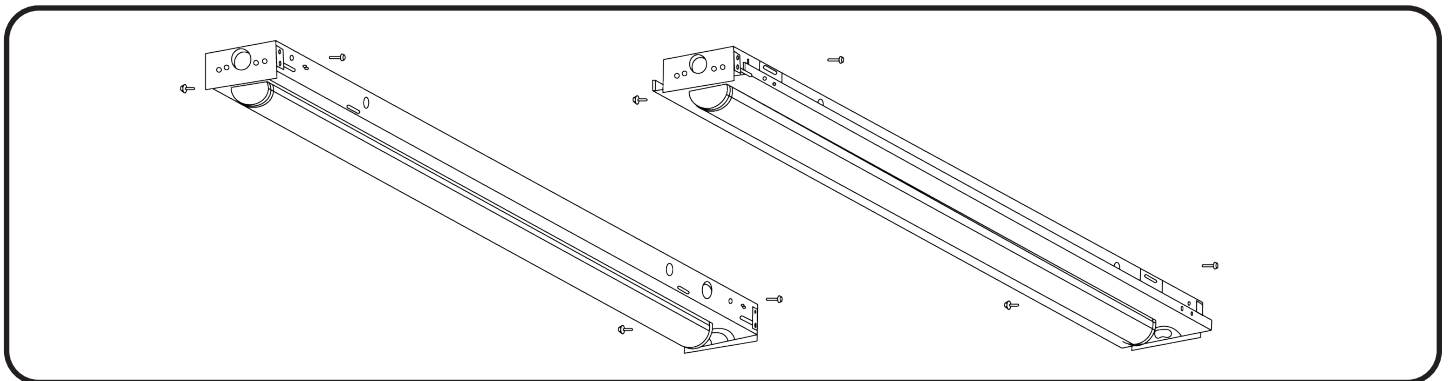

4 SECURE LED PANEL TO FIXTURE HOUSING: Once driver is properly energized, adjust bracket by opening or closing to snugly fit against fixture housing and secure LED panel to fixture housing by using the provided #8x1/2" self drilling screws. If there are no brackets, then use the #8x1/2" self drilling screws to secure the LED panel directly to the fixture housing.

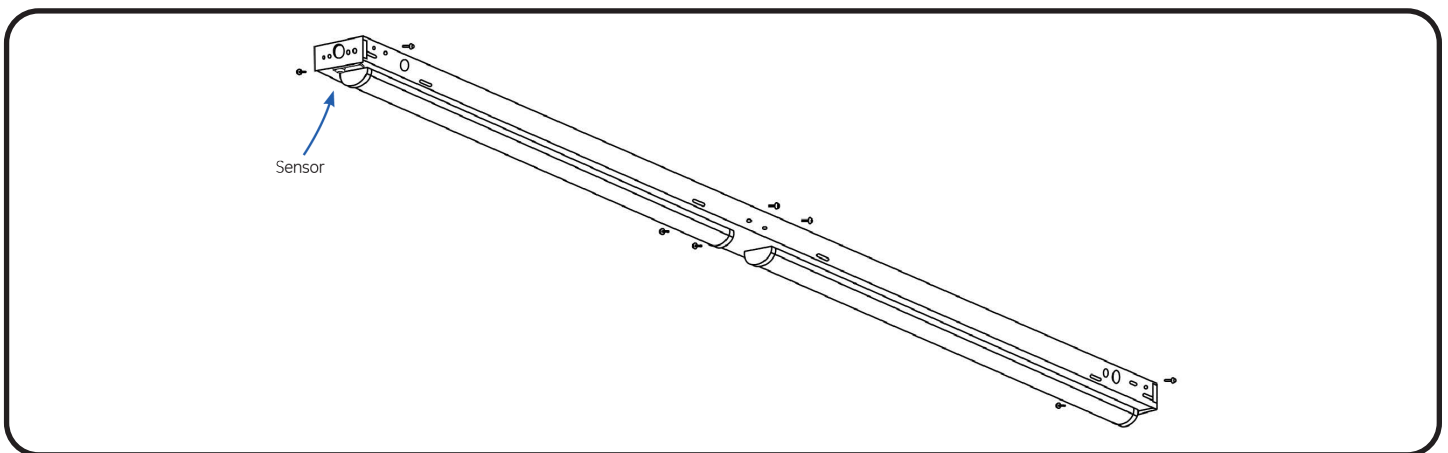

5 SECURE LED PANEL TO FIXTURE HOUSING (8ft. Kits): Connect the driver LED panel to the support LED panel using the 2 halves of the connector. Once driver is properly energized, adjust bracket by opening or closing to snugly fit against fixture housing and secure LED panels to fixture housing by using the provided #8x1/2" self drilling screws. If there are no brackets, then use the #8x1/2" self drilling screws to secure the LED panels directly to the fixture housing.

Wiring Diagrams

4 ft.

Connect Load and Neutral lines from branch power.

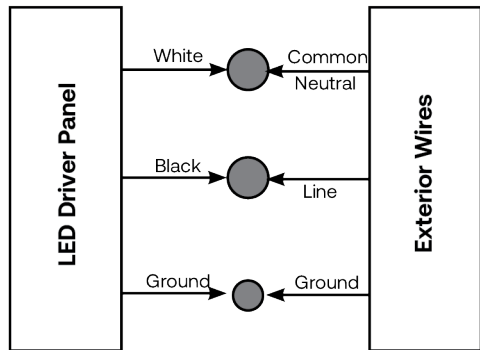

8 ft.

Connect Load and Neutral lines from branch power, and connect support panel to the driver panel.

