

The LVS-ERTB-NP-WH is a latching low voltage button switch. It is designed to be used as an emergency test switch with the ALCR1277. The assembly includes a standard high impact polycarbonate switch box cover plate.

### INSTALLATION

#### ALCR1277

(Cut the Blue Test Loop on the ALCR1277)

1. Connect one end of the Blue Test Loop wire to the Yellow (Common) wire on the button
2. Connect the other end of the Blue Test Loop wire to the White (Normally Closed) wire on the button
3. Cap the Blue (Normally Open) wire on the button
4. Install the plate onto the switch box, screws not provided

Note: ALCR1277 can only be used with LVS-ERTB-NP-WH

### DIMENSIONS

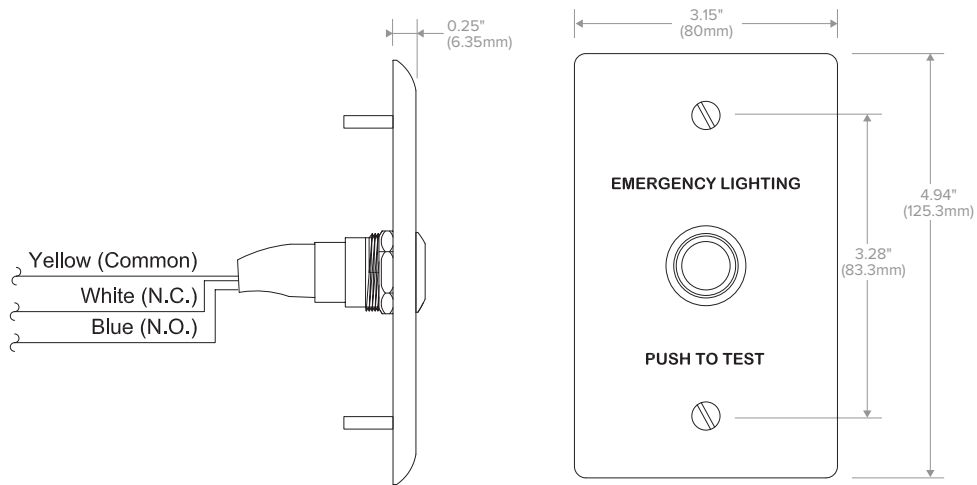

### WIRING DIAGRAM

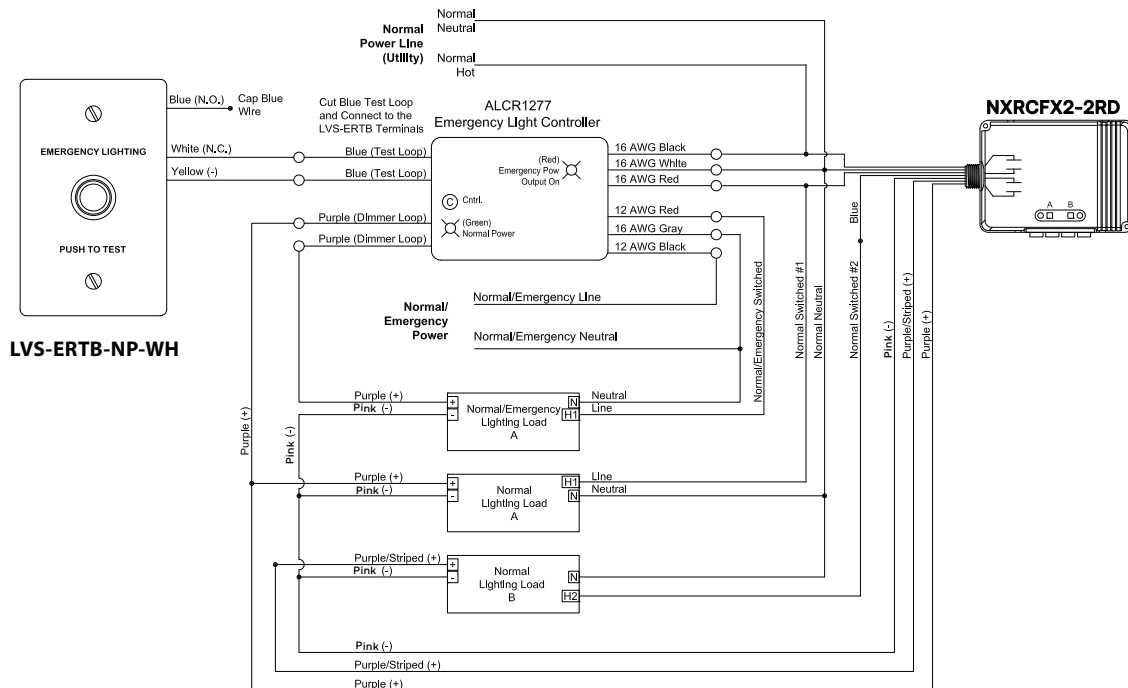

LVS-ERTB-NP-WH with ALCR1277