

Product Overview

The NXC-WA200 series Room Controllers are a lighting and plug load control solution for commercial and industrial buildings. These room controllers transmit and receive messages over a wireless IEEE 802.15.4 radio network to control zones of lighting. The devices are AC powered and provide On/Off switching as well as 0-10V analog dimming control for zones of LED drivers and ballasts.

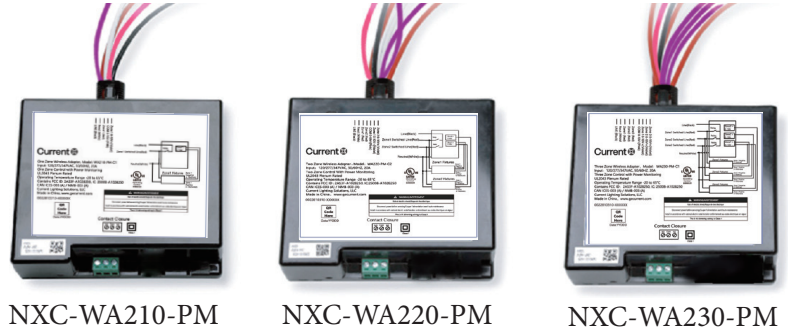

The NXC-WA200 series are available in three zone configurations: a single zone (NXC-WA210-PM), two-zone (NXC-WA220-PM), or three-zone (NXC-WA230-PM) controller. The zones are independently controllable using one dedicated switching relay and one dedicated 0-10V and dimming control circuit for its respective lighting control zone. Each controller also features one auxiliary (Form C) dry contact which can be used as an interface to a local Building Automation System (BMS) or as a switch to control secondary low power, low voltage switching components in the lighting system. The 0-10V dimming control is designed to bring the dimming level back up to maximum should power to the NXC-WA200 fail making it suitable for use with emergency lighting.

NXC-WA200 Room Controllers are ideally combined with NXC-WOS3-PC Ceiling Sensors and NXC-WWD2 Wall controls for room solutions that can be commissioned and zoned as a stand-alone room control solution for stand-alone room controls the system commissioning is performed via a free app available on the Apple store.



BEFORE YOU BEGIN

Read these instructions completely and carefully.

⚠ WARNING

⚠ WARNING		
RISK OF ELECTRIC SHOCK Disconnect power before servicing or installing product. Install in accordance with National Electric Code.	RISK OF INJURY OR DAMAGE Unit will fall if not installed properly. Follow installation instructions.	RISK OF INJURY Wear safety glasses and gloves during installation and servicing.

Save These Instructions

Use only in the manner intended by the manufacturer. If you have any questions, contact the manufacturer.

Important

To ensure the product warranty is valid, please ensure all installation instructions and environmental conditions for storage and operation are complied with. Installation to be

Prepare Electrical Wiring



Electrical Requirements

When replacing a line voltage switch, the power must be off at the branch circuit breaker. Bypass the line voltage switch to provide uninterrupted power to the fixtures and make sure the connection is properly insulated before installing the wireless switch.

Installation

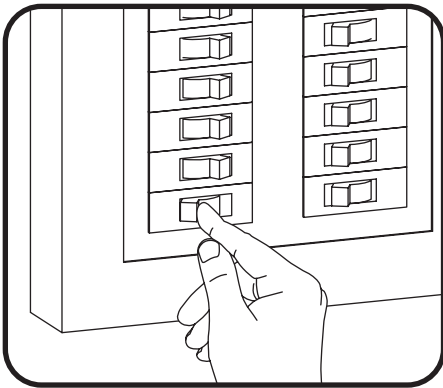

- 1 Disconnect power before installation. Turn off all power to affected light fixtures and supplies by turning off circuit breakers. Confirm that power is off at all light fixtures and supplies before continuing installation.

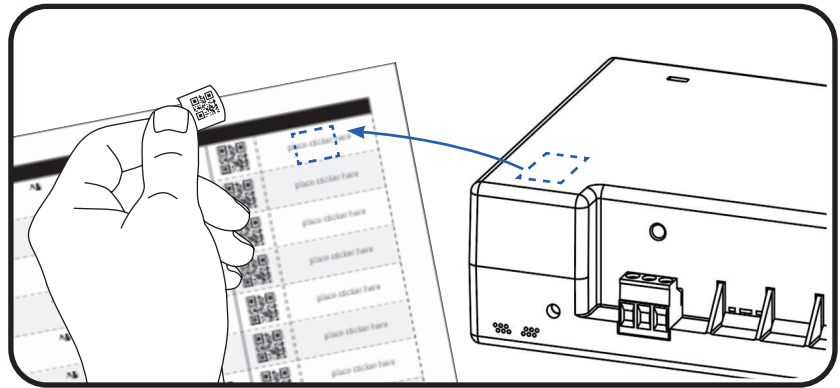

- 2 **IMPORTANT:** When installing affix the small label with 4-5 digits of the NXC-WA200 IEEE address on the floor plan and/or the start-up Workbook to indicate its location in the building. This will be needed when commissioning the wireless network.

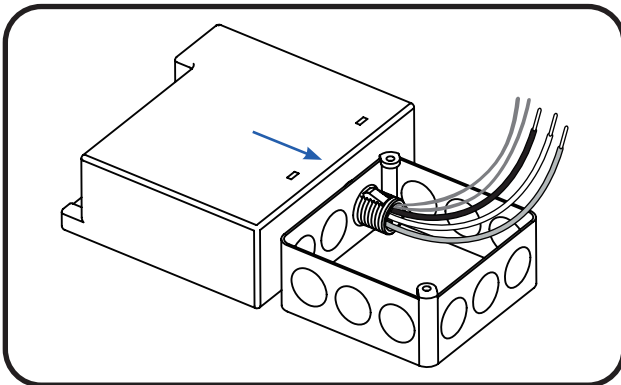

- 3 Mount the NXC-WA200 room controller to a wiring junction box approved for the application, by inserting the threaded barbed nipple of the NXC-WA200 series room controller through a convenient 1/2" knock-out on the junction box. Press firmly until the barbs engage inside the junction box. A threaded nut (not provided) may be used to further secure the nipple if desired.

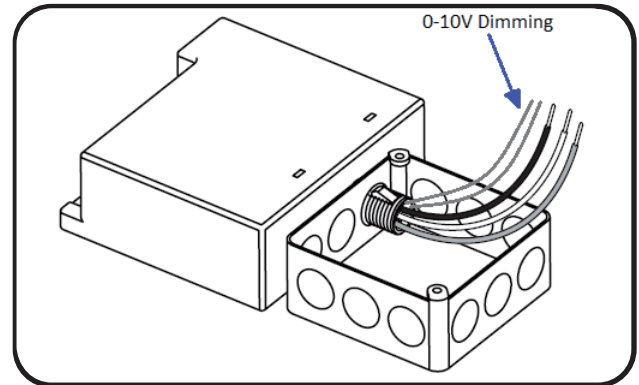

- 4 If present, connect any 0-10V dimming wires from each lighting zone to the corresponding dimming wires on the NXC-WA200 be careful to observe polarity of the + (violet) and - (pink) dimming leads.
NOTE: The 0-10V wiring is Class 1.

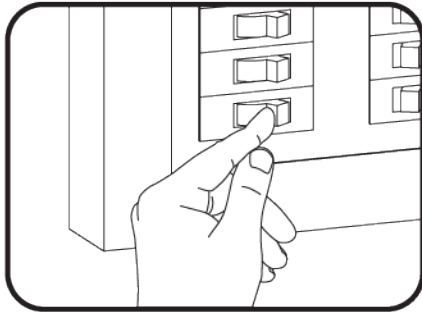

⑥ Turn on the circuit breaker providing power to the NXC-WA200 series room controller. All lighting loads connected to the NXC-WA200 series room controller will turn ON when power is initially applied (and when power is restored after a power failure).

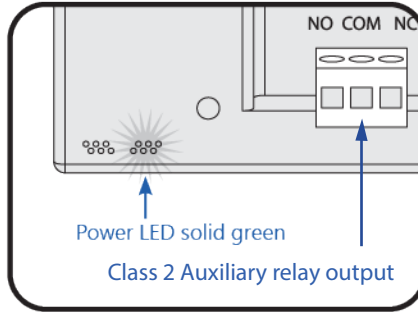

⑦ Ensure the Power LED on the NXC-WA200 series room controller is solidly illuminated.

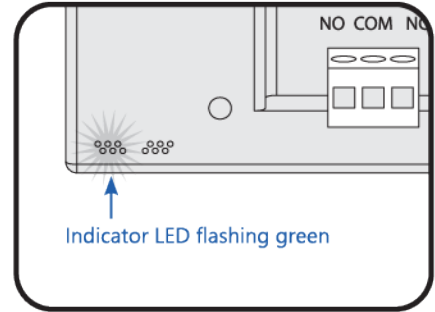

⑧ Ensure that the Indicator LED is rapidly flashing. This will indicate that the NXC-WA200 series room controller is searching for a wireless network to join. If the Indicator LED is not flashing rapidly, press and hold the Reset button for at least 6 seconds to perform a factory reset on the controller.

- ⑨ At this time, you may perform a self-test to verify that each lighting zone is properly connected to its respective NXC-WA200 zone. Please review the Test Mode section on the following page for more details.
- ⑩ Commission the NXC-WA200 Room Controllers, NXC-WOS3-PC Ceiling Sensors and NXC-WWD2 wall devices with the app for room based zonal controls of lighting. The app is available on the Apple® App Store. The NXC-WA200 Wireless Room control devices can also be commissioned as a networked wireless lighting control system using the cloud based software.

NOTE: In EZ Connect mode, the Class 2 Auxiliary form C relay is linked to Zone 1. It is controlled by the motion sensors and can be used to integrate with the BM system providing occupancy status via the NO or NC dry contacts.

Test Mode

When the NXC-WA200 series room controller has been first installed (or a factory Reset has been performed) the Indicator LED will flash rapidly indicating that the device is trying to join a wireless network. At this time, it is possible to initiate a Test Mode that will flash each connected lighting load to verify proper installation of the device.

1. Check the indicator light to ensure it is rapidly flashing. This condition is required for the Test Mode to operate. If the device is already connected to a wireless network the indicator LED will be OFF and the Test Mode will not be available. NOTE: A Factory Reset can be performed to allow the Test Mode to operate but this will disconnect the NXC-WA200 series room controller from a wireless network and require the NXC-WA200 series room controller to be re-commissioned.
2. Observing that the Indicator LED is rapidly flashing, **briefly** press the Reset button once (for less than 1 second). This will cause the lighting load in Zone 1 to be cycled ON and OFF repetitively while dimming the lights up and down (if 0-10V dimming is being used in that zone). This allows the installer to confirm which lighting load is connected to the Zone 1 Switched Line and also verify that the Zone 1 dimming leads, if used, are properly connected. If no second zone is equipped(NXC-WA210)pressing the Reset button a second time will begin testing the Auxiliary Relay Contact (Step #5 below).
3. Observing that the Zone 1 Test Mode is operating, briefly press the Reset button again. This will cause the lighting load connected to Zone 2 Switching Line to cycle ON and OFF, while dimming up and down. If no third zone is equipped(NXC-WA220)pressing the Reset button a third time will begin testing the Auxiliary Relay Contact (Step #5 below).
4. Observing that the Zone 2 Test Mode is operating, briefly press the Reset button again to cause lighting Zone 3 to begin flashing ON and OFF and dimming up and down.
5. Pressing the Reset button again will cause the Auxiliary Relay Contact to begin alternately cycling OPEN and CLOSED.
6. One additional press of the Reset button will cause the NXC-WA200 series room controller to enter an Identify Test Mode. During the Identify Test Mode, the indicator LED will repetitively flash four times followed by a pause and all connected lighting zones will turn ON and OFF.
7. One additional press of the Reset button will return the NXC-WA200 to normal operation (Test Mode disabled).
8. Continued pressing of the Reset button will continue to cycle through the various Zone Test Modes described above.
9. The Test Modes will automatically time out if the Reset button has not been pressed for 5 minutes.
10. Once joined to a network, all Test Modes will be entirely disabled in the NXC-WA200 series room controller

Indicator LED Pattern	WA200 Status
Rapidly Flashing	Seeking to join Wireless System
Repetitive Flash – Once per second	Zone 1 Test Mode
Repetitive Flash – Twice per second	Zone 2 Test Mode (WA220 and WA230 only)
Repetitive Flash – Three times per second	Zone 3 Test Mode (WA230 Only)
Repetitive Flash – Four times per second	Auxiliary Contact Relay Test Mode
Slow Flashing	Device joined a network but not yet zoned
No Light	Device joined a network and been zoned
Repetitive Flashing (Four times) followed by a Pause	a wireless network

Emergency Lighting Installation

The 0-10V dimming control in the NXC-WA200 series room controller is designed to bring the dimming level back up to maximum, should power to the NXC-WA200 series room controller be interrupted. This is a required feature if a lighting zone is to be used for emergency egress lighting in the building. It should be noted that the relays used to switch each lighting zone do not have any emergency transfer feature themselves, and therefore the RED Zone "Switched" connections should NOT be used to control ON/OFF functionality of the emergency lighting.

Consequently, ON/OFF functionality used for emergency egress must either be controlled using a safety rated emergency transfer switch or if the fixtures are equipped with dim-to-off functionality, they can be controlled OFF using the 0-10V dimming control by lowering the dimming control below the "Off Threshold" of the device. Consult your fixture manufacturer for instructions on how to turn the lights OFF using the dimming leads if your particular lighting fixtures are so equipped.

An example for wiring an emergency lighting zone (Zone 3 in this example) is illustrated below. Notice that the "Zone 3 Switched Line" is NOT connected to the line supply of the Zone 3 emergency egress fixtures. Instead, the zone is supplied from an emergency building supply.

Notice too, that the Zone 3 emergency luminaires are connected to the Zone 3 dimming control. If this zone has dim-to-OFF capability, the dimming leads which are connected to the wireless zone controller may be used to turn OFF the entire lighting zone. And if the NXC-WA200 should ever experience a power failure, the Zone 3 dimming leads will go to the maximum dimming control level of the Zone 3 lighting and illuminate Zone 3 to its maximum light output level.

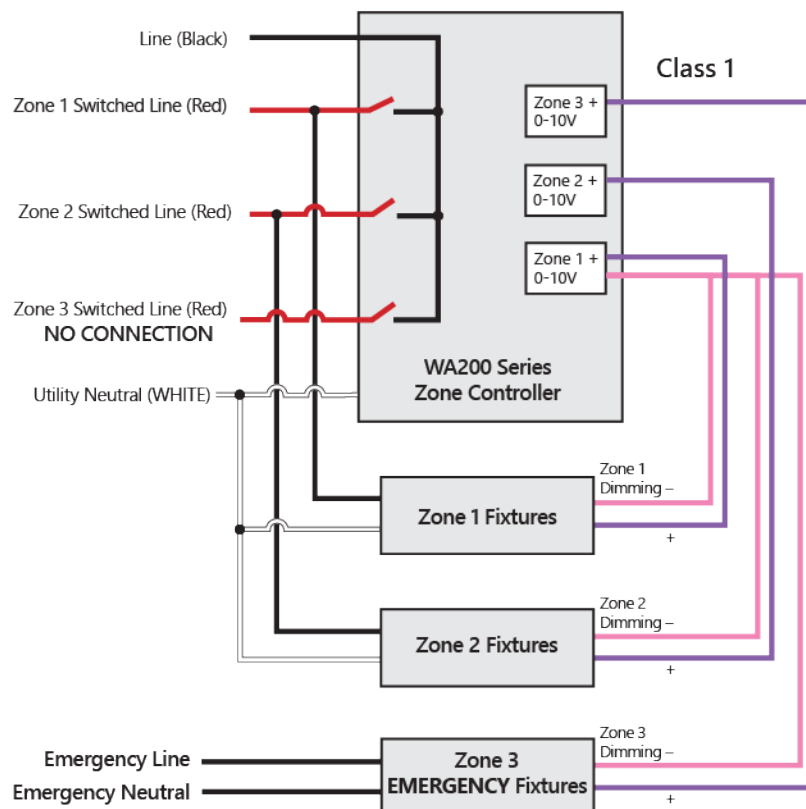

Connecting to a stand-alone room

When first powered up (or following a factory reset), the NXC-WA200 series Wireless Room Controllers will start searching for a wireless network to join. As described in the table on page 5, this is indicated by a rapid flashing pattern on the Indicator LED. The commissioning contractor must download the app on the Apple® App Store and the devices can be programmed using the app.

Contains
FCC ID: 2AS3F-A1028250
IC: 25008-A1028250

CAN ICES-003 (A) / NMB-003 (A)

Caution: Any changes or modifications not expressly approved by the party responsible for compliance could void the user's authority to operate this equipment.

This device complies with part 15 of the FCC Rules. Operation is subject to the following two conditions: (1) This device may not cause harmful interference, and (2) this device must accept any interference received, including interference that may cause undesired operation. This device contains license-exempt transmitter(s)/ receiver(s) that comply with Innovation, Science and Economic Development Canada's license-exempt RSS(s). Operation is subject to the following two conditions:

1. This device may not cause interference.
 2. This device must accept any interference, including interference that may cause undesired operation of the device.
- L'émetteur/récepteur exempt de licence contenu dans le présent appareil est conforme aux CNR d'Innovation, Sciences et Développement économique Canada applicables aux appareils radio exempts de licence. L'exploitation est autorisée aux deux conditions suivantes:
1. L'appareil ne doit pas produire de brouillage;
 2. L'appareil doit accepter tout brouillage radioélectrique subi, même si le brouillage est susceptible d'en compromettre le fonctionnement.

Note: This equipment has been tested and found to comply with the limits for a Class A digital device, pursuant to part 15 of the FCC Rules. These limits are designed to provide reasonable protection against harmful interference when the equipment is operated in a commercial environment. This equipment generates, uses, and can radiate radio frequency energy and, if not installed and used in accordance with the instruction manual, may cause harmful interference to radio communications. Operation of this equipment in a residential area is likely to cause harmful interference in which case the user will be required to correct the interference at his own expense.

To satisfy FCC/ISED RF exposure requirements a separation distance of 20 cm or more must be maintained between the antenna of this device and persons during operation. Operation at closer than 20cm is not permitted.

Pour être conforme aux limites d'exposition aux ondes RF des normes FCC/ISED, une distance de séparation d'au moins 20 cm doit être maintenue entre l'antenne de cet appareil et toute personne pendant son opération. Mettre en opération cet appareil à une distance plus rapprochée que 20 cm n'est pas permis.