

# TR3 Front Lens Shell



## BEFORE YOU BEGIN

Read these instructions completely and carefully. If you prefer to have this Installation Instructions document in other languages, visit our official website at: [www.LED.com/transportation](http://www.LED.com/transportation)

### ⚠ WARNING / AVERTISSEMENT

#### RISK OF ELECTRIC SHOCK

Disconnect Before Servicing or installing product. The LED module must be installed into a signal head with adequate ingress protection for the location (protection from the weather).

#### RISQUES DE DÉCHARGES ÉLECTRIQUES

Couper l'alimentation avant le dépannage ou avant l'installation du produit. Le module DEL doit être installé dans une tête de signal avec une protection adéquate d'entrée pour l'emplacement (protection contre les intempéries).

## Prepare Electrical Wiring



#### Electrical Requirements

- Follow all National Electric Codes (NEC) and local codes.

## Important Information

- Removal of the internal power supply will void your warranty.
- Always WEAR gloves.
- Usage of a plastic and non-powered screwdriver is recommended to prevent lens damage or scratching.
- DO NOT touch the front shell at ANY TIME without gloves.
- DO NOT rest the front shell on its external surface to avoid scratches.
- Failure to properly follow these instructions may cause signal to malfunction.
- The customer is responsible of the optical validation of the newly installed lens.
- This product is intended solely for the use of rail signaling and is not intended for use in any other applications.

This device complies with part 15 of the FCC Rules. Operation is subject to the following two conditions: (1) This device may not cause harmful interference, and (2) this device must accept any interference received, including interference that may cause undesired operation.

CAN ICES-005 (A)/NMB-005(A)

NOTE: This equipment has been tested and found to comply with the limits for a Class A digital device, pursuant to part 15 of the FCC Rules. These limits are designed to provide reasonable protection against harmful interference when the equipment is operated in a commercial environment. This equipment generates, uses, and can radiate radio frequency energy and, if not installed and used in accordance with the instruction manual, may cause harmful interference to radio communications. Operation of this equipment in a residential area is likely to cause harmful interference in which case the user will be required to correct the interference at his own expense.

## Installation Steps

NOTE: Failure to properly follow these instructions may cause signal to malfunction. Pictures are for reference only. Actual lens shape may appear different.

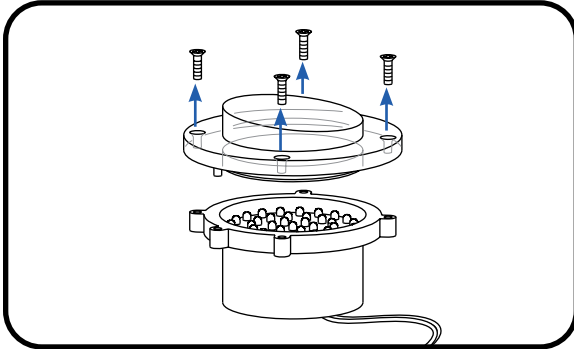

- 1 Lay down the lamp on a clean workbench on its back shell to ensure no scratches on the front shell. Remove the 4 top screws and pull the front shell off.

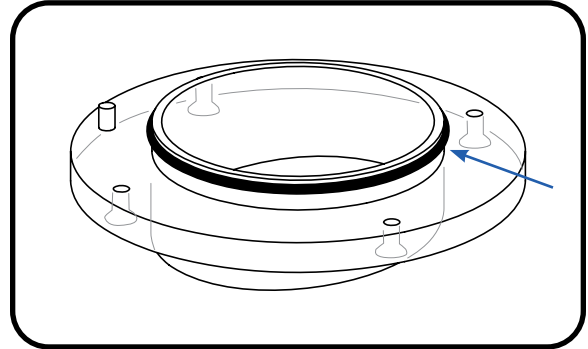

- 2 Verify that the black gasket is well seated in the lens. If required, use your fingers to push it in place.

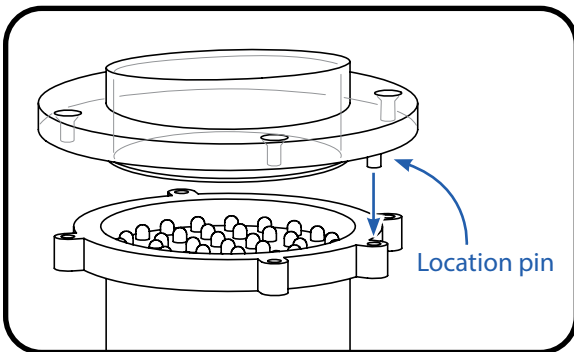

- 3 Using gloves, gently place the new front shell on the back shell. Align the lens location pin to the location pinhole on the back shell.

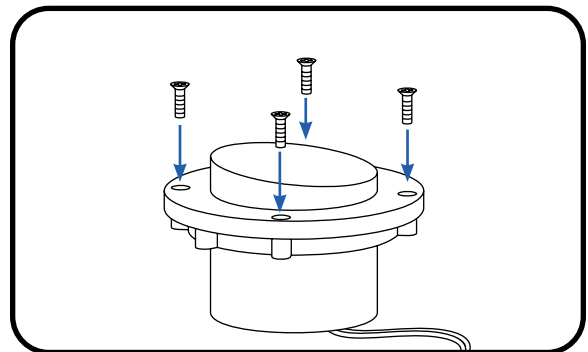

- 4 Insert and fasten all four screws into the front shell. (Torque between 4 and 5 inch-pounds).  
NOTE: Screw stripping or lower torque may cause water to penetrate the lamp.

The lamp is ready to be installed in the field as per Current's installation instructions.