

# ACE<sup>®</sup> LED Signals Retrofit for Transit and Wayside



TR3-WFFB-101A



## BEFORE YOU BEGIN

Read these instructions completely and carefully. If you prefer to have this Installation Instructions document in other languages, visit our official website at: [www.LED.com/transportation](http://www.LED.com/transportation)

### **⚠ WARNING / AVERTISSEMENT**

#### **RISK OF ELECTRIC SHOCK**

Disconnect Before Servicing or installing product. The LED module must be installed into a signal head with adequate ingress protection for the location (protection from the weather).

#### **RISQUES DE DÉCHARGES ÉLECTRIQUES**

Couper l'alimentation avant le dépannage ou avant l'installation du produit. Le module DEL doit être installé dans une tête de signal avec une protection adéquate d'entrée pour l'emplacement (protection contre les intempéries).

## Operating Specifications

Input Voltage Range	88V to 132V AC
Current Draw	0.060A minimum at 132V 0.084A nominal at 110V 0.136A maximum at 88V

## Prepare Electrical Wiring



#### *Electrical Requirements*

- Follow all National Electric Codes (NEC) and local codes.

## Important Information

- Use only with alternating current (AC) interlocking.
- Do not attempt to open the LED module. No assembly is required.
- As per AREMA guidelines, provisions should be made for periodic functional checks of safety devices and features incorporated into this product.
- Current recommends that primary and secondary surge protection be added additional to the tertiary surge protection in the lamp. Arema 11.3.3
- This product is intended solely for the use of rail signaling and is not intended for use in any other application.

This device complies with part 15 of the FCC Rules. Operation is subject to the following two conditions: (1) This device may not cause harmful interference, and (2) this device must accept any interference received, including interference that may cause undesired operation.

CAN ICES-005 (A)/NMB-005(A)

**NOTE:** This equipment has been tested and found to comply with the limits for a Class A digital device, pursuant to part 15 of the FCC Rules. These limits are designed to provide reasonable protection against harmful interference when the equipment is operated in a commercial environment. This equipment generates, uses, and can radiate radio frequency energy and, if not installed and used in accordance with the instruction manual, may cause harmful interference to radio communications. Operation of this equipment in a residential area is likely to cause harmful interference in which case the user will be required to correct the interference at his own expense.

## Testing

If testing before installation, be sure to use a **constant power source rated 110V AC / 1A minimum** to ensure proper operation of the LED signal. **NOTE:** Failure to do so will activate the light-out safety detection feature of the LED signal and disable the lamp's operation.

## Installation Steps

**NOTE:** Failure to properly follow these instructions may cause signal to malfunction.

- 1 Shut off power.

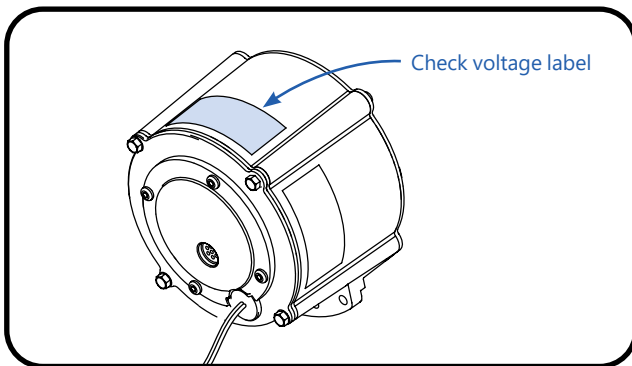

- 2 **Voltage settings:** Check the label on the side of the LED module to ensure the voltage corresponds to the system voltage. Failure to do so will cause the lamp to fail.

- 3 **Existing signal head in the field:** Remove incandescent bulb OR existing LED signal module. Retain all hardware removed as it may be needed in subsequent steps.

**NOTE:** Installer is responsible for ensuring the disposal of removed components complies with all applicable regulatory requirements.

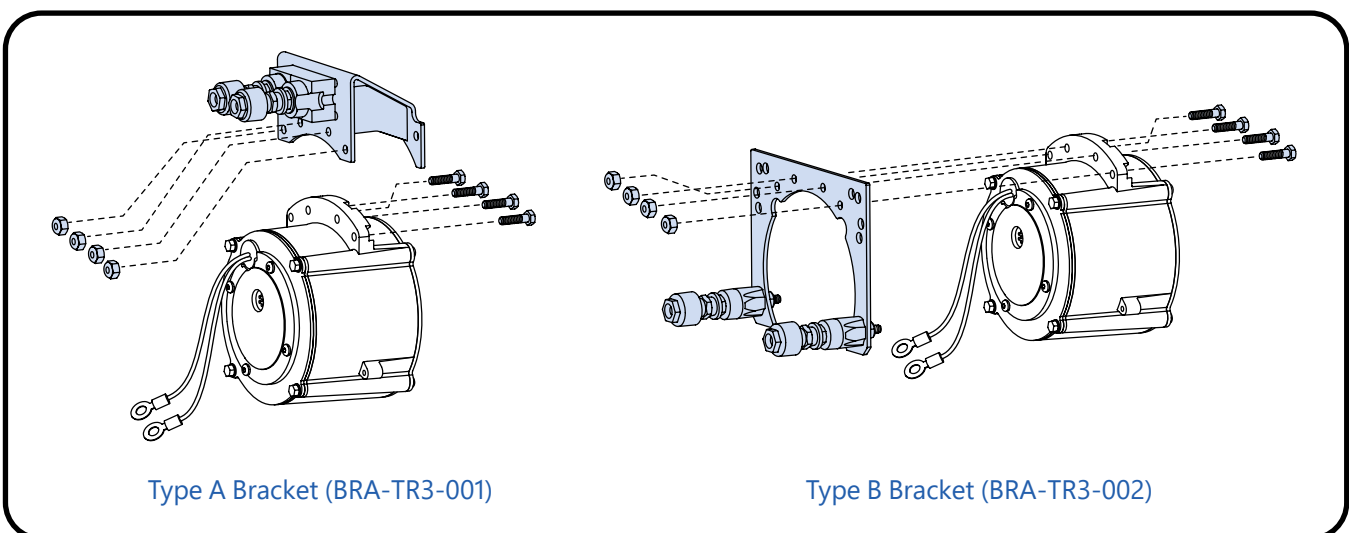

- 4 **Mount LED signal to corresponding bracket:** Fasten the 4 bolts provided and ensure that the bolt heads are sitting squarely within the slots provided on the LED signal module.

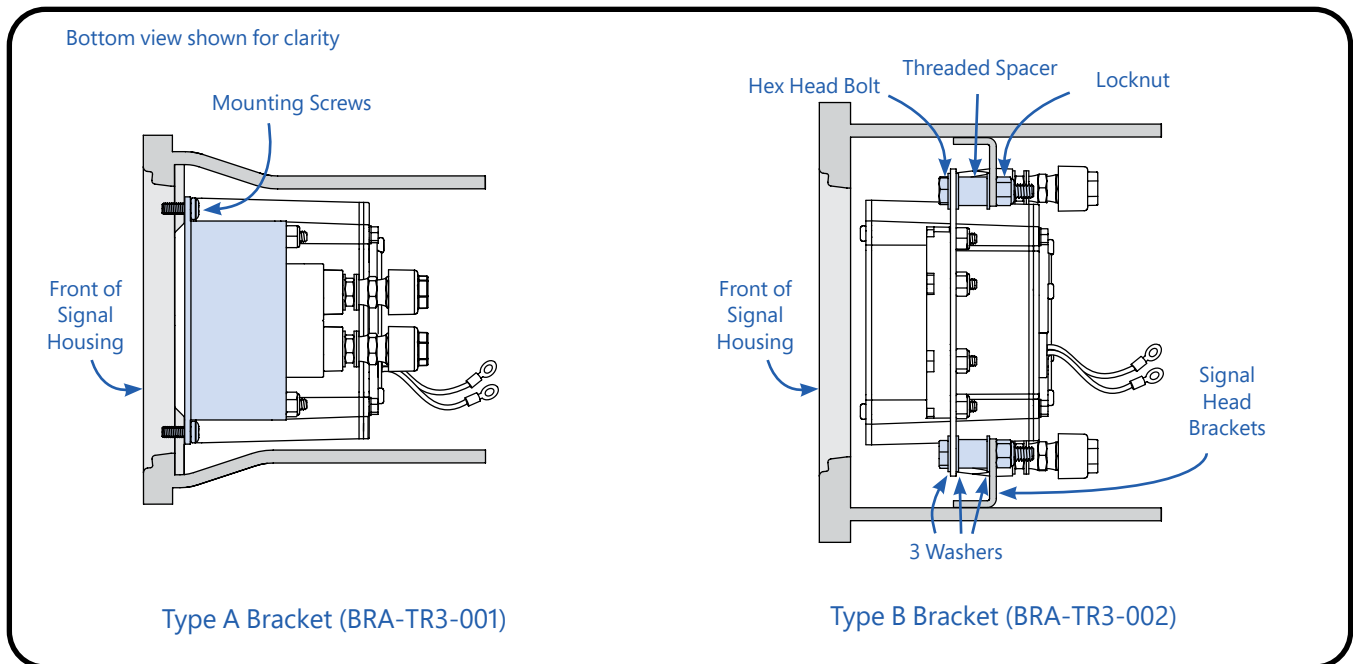

- ⑤ **Fasten the LED signal to the signal head:** Ensure that the module is securely fastened to the signal head using the hardware provided.  
**Note:** To ensure electrical safety and operation to all specifications, the LED signal module must be reliably bonded to ground through the mounting bracket.
- ⑥ **Alignment:** Verify that the LED signal module is aligned with the center of the signal head lens.
- ⑦ **Connect wires:** Connect the LED signal wires to the AAR terminal block provided with the bracket.
- ⑧ **Test unit:** Apply power and ensure proper operation of LED signal modules.