

LED Systems Power Supply

24
Volt

GEPS24D-80U (100-277 VAC input/24VDC output/80W/0-10V Dimming)

Power Supply Features

- Supports all 24 VDC Tetra Products
- Dry and Damp Locations Rated
- Class 2 Power Supply
- 100-277 VAC Input
- Compatible with 0-10V Dimming controller

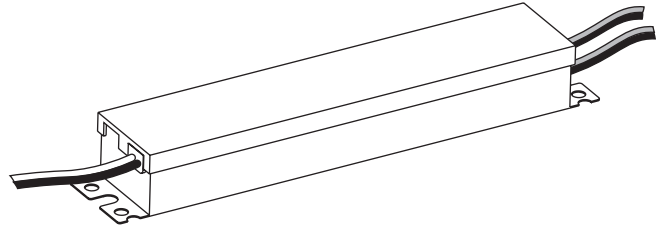

BEFORE YOU BEGIN

Read these instructions completely and carefully.

⚠ WARNING / AVERTISSEMENT

RISK OF ELECTRIC SHOCK

- Disconnect power at fuse box or circuit breaker before servicing or installing product.
- Properly ground Tetra® power supply.
- Must be enclosed in an end product.

RISK OF FIRE

- In the end product, power supply spacing to other heat producing components shall be minimum 2 inches spacing to sidewalls and minimum 2 inches spacing to top of enclosure.
- Adjacent power supplies shall be spaced at least 1 in. end to end and 4 in. in any other direction.
- Use only approved wire for input/output connection. Minimum size 18 AWG (0.82 mm²).
- Follow all local codes.
- Application considerations potentially requiring additional spacing include high ambient temperature seen by the power supply, poor contact with a heat dissipating material, inadequate ventilation, or direct exposure to sun.

RISQUES DE DÉCHARGES ÉLECTRIQUES

- Coupez l'alimentation électrique à la boîte de fusibles ou au disjoncteur avant l'entretien ou l'installation du produit.
- Assurez-vous de correctement mettre à terre le bloc d'alimentation Tetra®.
- Doit être inclus à l'intérieur d'un produit final.

RISQUES D'INCENDIE

- Dans le produit fini, l'espacement entre le bloc d'alimentation et les autres composants dégageant de la chaleur doit être d'au moins 2 pouces des parois latérales et d'au moins 2 pouces du haut de l'enceinte.
- Les blocs d'alimentation adjacents doivent être espacés d'au moins 1 po de bout en bout et 4 po dans toute autre direction.
- N'utilisez que des fils approuvés pour les entrées/sorties de connexion. Taille minimum 18 AWG (0.82 mm²).
- Respectez tous les codes locaux.
- Certaines applications pourraient requérir un espacement additionnel, p. ex. une température ambiante élevée autour du bloc d'alimentation, un mauvais contact avec une matière dissipatrice de chaleur, une ventilation inadéquate ou une exposition directe au soleil.

⚠ CAUTION / ATTENTION

RISK INJURY

- While performing installations described, gloves, safety glasses or goggles should be worn.

RISQUES DE BLESSURE

- Lors de l'exécution des installations décrites, des gants, des lunettes de sécurité ou des lunettes de protection doivent être portées.

Prepare Electrical Wiring



Electrical Requirements

- Limited to use in dry and damp locations.
- The suitability of rain enclosure shall be determined if intended for wet location.
- The grounding and bonding of the LED Driver shall be done in accordance with National Electric Code (NEC) Article 600.
- Follow all National Electric Codes (NEC) and local codes.

Save These Instructions

Use only in the manner intended by the manufacturer. If you have any questions, contact the manufacturer.

Power Supply Installation

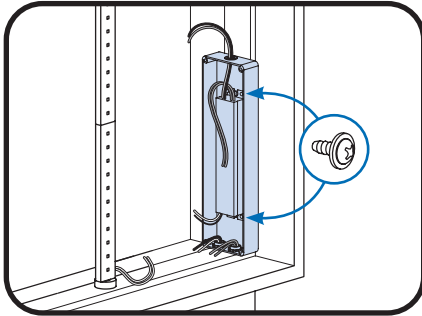

- 1 Mount the power supply with the base in contact with the mounting surface in an electrical enclosure with adequate dimensions to satisfy the power supply spacing requirements described above, and suitable for the installation environment. The power supply and electrical connections shall be protected from weather and not subject to saturation with water or other liquids. If not protected from the weather, the output and dimming connections may be sealed with electrical grade silicone.

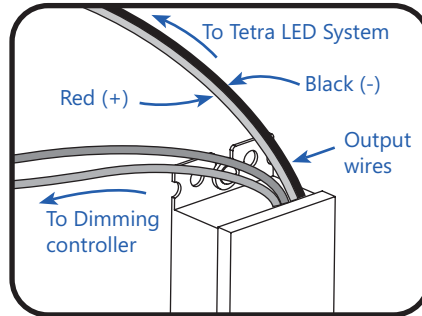

- 2 Connect the supply wire that is attached to the Tetra LED System to the red (+) and black (-) output wires of the power supply as outlined in the "Electrical Connections" section of your LED system's **Installation Instructions**.

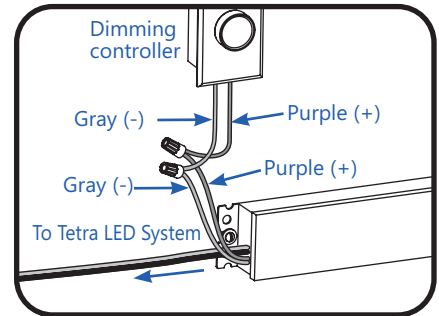

- 3 Connect the (+) purple and (-) gray wires of the Tetra Dimming Power Supply to the 0-10V dimming controller. Refer to the dimming controller installation instructions for specific connection information.

NOTE: To avoid overloading this power supply with LED modules, please refer to the specific module loading guides.

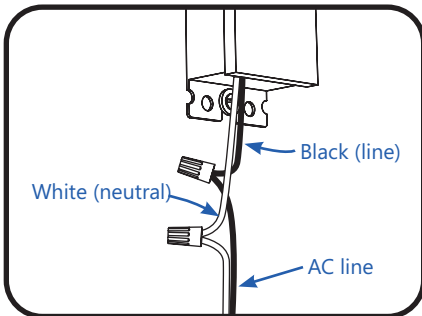

- 4 Connect the AC line to the black (line) and white (neutral) input wires of the power supply using 18-14 AWG (0.82-2.08 mm²) or 18-10 AWG (0.82-5.26mm²) twist-on wire connectors. Properly ground power supply in accordance with National Electric Code (NEC) Article 600.

NOTE: For CSA approval, a disconnect/toggle switch of appropriate rating needs to be placed within 29.5 ft. (9 m) of primary side of the power supply. The minimum rating of the switch must be either 120 or 220 Volts AC. The switch must also support twice the amount of input current.

NOTE: When installing power supply, connect to the appropriate sized building breaker or disconnect device for line and neutral connections, in accordance with local, state or country regulations.

NOTE: The grounding and bonding of the power supply and overall sign shall be done in accordance with National Electric Code (NEC) Article 600.

OPTIONAL

A Weather Box (GEXNWB2) may be used to house and seal Class 2 connections.

A) Insert wire connectors into weather box. Fill with electrical grade silicone and close box.

B) Secure the weather box using a #6 or #8 (M2 or M3) screw.

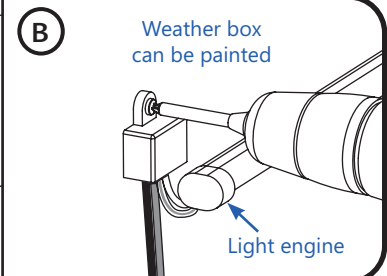
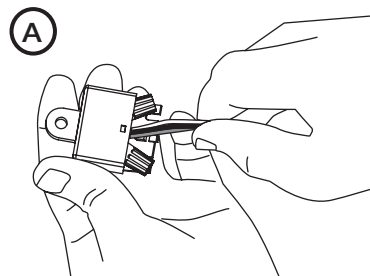

Power Supply Specifications

Performance Data	Min	Typical	Max
Input Voltage (VAC)	90	100-277	305
Input Frequency (Hz)	–	50/60	–
Input Current (A)	–	–	1.1
THD	–	–	20
PF	0.9	–	–
Output Voltage (VDC)	23.0	–	25.5
Output Current (ADC)	–	–	3.3
Output Power (W)	–	–	80
Environmental Operating Temperature Range	-40°C	+25°C	+60°C*
Environmental Humidity (non-condensing)	10%	–	90%
Environmental Storage Temperature Range	-40°C	–	+85°C
Environmental Rating	IP66 rated: must be protected from direct exposure to the weather		
Dimensions	9.5 in. x 1.7 in. x 1.2 in. (240 mm x 43 mm x 30 mm)		

*Maximum case temperature is 85°C

Troubleshooting

Symptom	Solution
All letters are OFF	<ul style="list-style-type: none"> Recycle AC power, turn it off, then turn on again. If still off, check the power supply DC output voltage using a voltmeter. It should be nominally 24V. <ul style="list-style-type: none"> » If there is DC output, inspect and correct all DC wire damage/polarity issues; If no issue is found, replace the OFF-module string. » If there is no DC output, have a licensed electrician check the input AC voltage and if there is correct AC voltage, replace the power supply. » If there is no AC voltage, correct the upstream AC issue.
Some LEDs appear dim	<ul style="list-style-type: none"> Ensure the overall length of the Tetra® LED System does not exceed the maximum load. Ensure the length of supply wire is equal to or below the recommended remote mounting distance.
Some of the letters are not illuminated	<ul style="list-style-type: none"> Inspect and correct the wires of the non-illuminated letters for damage/polarity issues; If no issues are found, see the troubleshooting solution for "All letters are OFF."
Shadows	<ul style="list-style-type: none"> Re-route supply wire and secure to the back of the can with electrical grade RTV silicone. Adjust wire connector orientation so that it does not cover any LEDs. Adjust LED layout to ensure uniformity of illumination of the face of the letter.

This device complies with part 15 of the FCC Rules. Operation is subject to the following two conditions: (1) This device may not cause harmful interference, and (2) this device must accept any interference received, including interference that may cause undesired operation.

Note: This equipment has been tested and found to comply with the limits for a Class A digital device, pursuant to part 15 of the FCC Rules. These limits are designed to provide reasonable protection against harmful interference when the equipment is operated in a commercial environment. This equipment generates, uses, and can radiate radio frequency energy and, if not installed and used in accordance with the instruction manual, may cause harmful interference to radio communications. Operation of this equipment in a residential area is likely to cause harmful interference in which case the user will be required to correct the interference at his own expense.

This Class [A] RFLD complies with the Canadian standard ICES-005. Ce DEFR de la classe [A] est conforme à la NMB-005 du Canada.

This product is intended to be used as a lamp control gear that is installed after the mains control switch.

Conforms to the following standards:



For the most up-to-date version of this installation guide, please visit <https://products.LED.com/sign-lighting>