

# LED Upgrade Kit Installation Guide

Fixture: PROB™ - PROVIDENCE BOLLARD



**WARNING:** Fixtures must be grounded in accordance with local codes or the National Electrical Code. Failure to do so may result in serious personal injury.

**MAINTENANCE:** A regularly scheduled maintenance program should be established to retain optimum light output and reduce heat retention. Dusting with a soft, clean, dry cloth is normally sufficient for the optics.

**CAUTION:** All wiring must be done by a qualified electrician. KEEP THIS SHEET FOR FUTURE REFERENCE.

Examine all parts that are not intended to be replaced by the retrofit kit for damage and replace any damaged parts prior to installation of the retrofit kit.

Examinez toutes les parties qui ne sont pas destinés à être remplacé par le kit d'adaptation pour les dommages et remplacer les pièces endommagées avant l'installation du kit de renovation.

## UPGRADE KIT CONTENTS

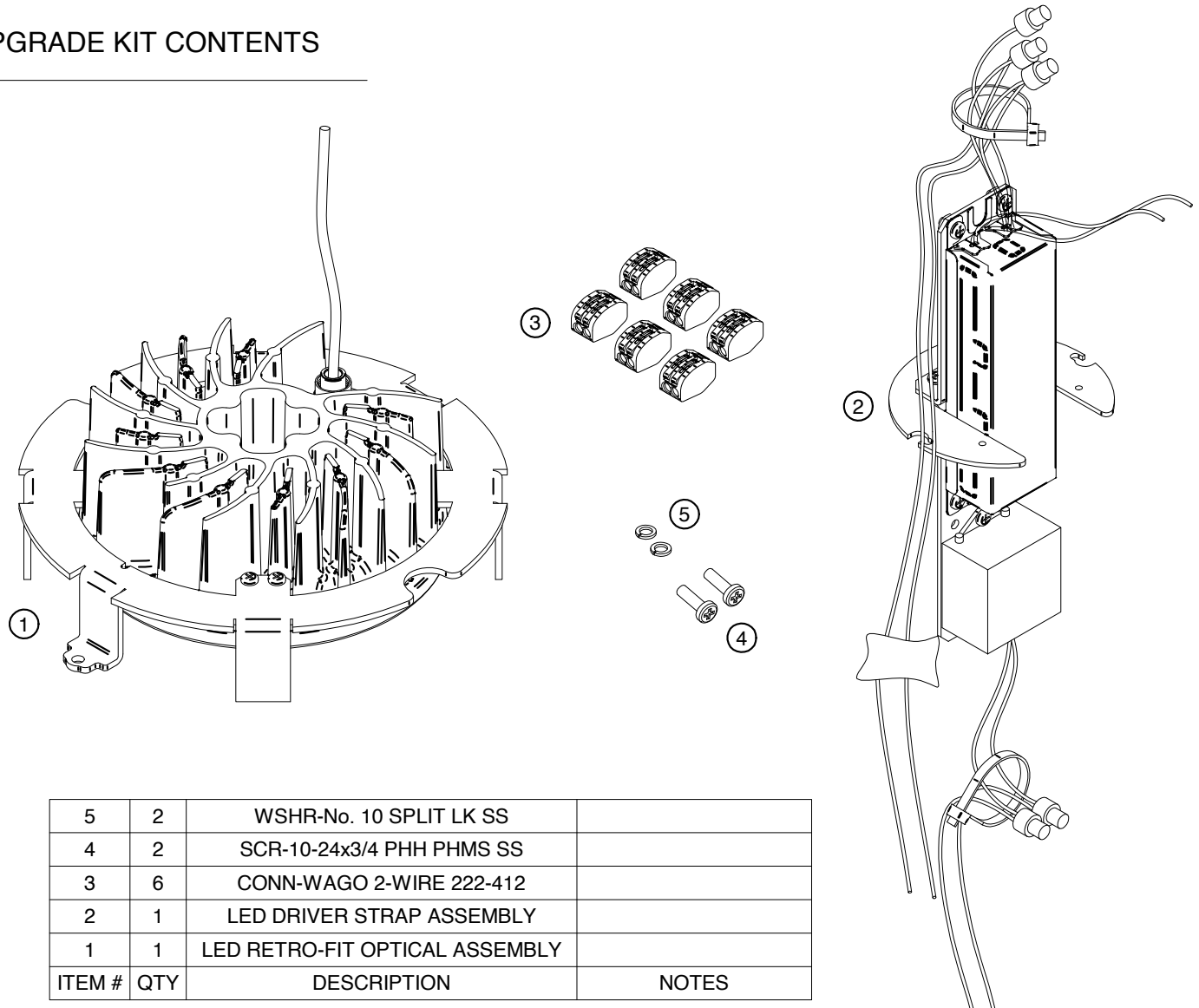

5	2	WSHR-No. 10 SPLIT LK SS	
4	2	SCR-10-24x3/4 PHH PHMS SS	
3	6	CONN-WAGO 2-WIRE 222-412	
2	1	LED DRIVER STRAP ASSEMBLY	
1	1	LED RETRO-FIT OPTICAL ASSEMBLY	
ITEM #	QTY	DESCRIPTION	NOTES

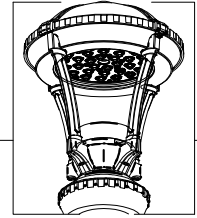

# LED Upgrade Kit Installation Guide

Fixture: PROB™ - PROVIDENCE BOLLARD

 TURN OFF ALL POWER TO THE UNIT AND TAKE PROPER SAFETY PRECAUTIONS. FAILURE TO DO SO MAY RESULT IN SERIOUS PERSONAL INJURY.

## STEPS: TO DIS-ASSEMBLE EXISTING ASSEMBLY:

### ACCESS TOP DOME COMPARTMENT

1. TURN OFF POWER.
2. LOOSEN CAPTIVE SCREW AND LIFT TOP DOME TO ACCESS DOME COMPARTMENT.
3. REMOVE EXISTING OPTICAL SYSTEM IN THE FIXTURE DOME AND DISCARD.

### ACCESS DRIVER COMPARTMENT

1. TURN OFF POWER.
2. REMOVE 3X 5/16-18 X 3/8" SET SCREWS AND REMOVE FIXTURE HEAD ASSEMBLY TO ACCESS DRIVER COMPARTMENT.
3. REMOVE DRIVER ASSEMBLY FROM BOTTOM FITTER BY LOOSENING 2X 8-32 SCREWS AND TWIST COUNTER CLOCKWISE. PULL IT OUT AND DISCONNECT WIRES AND DISCARD

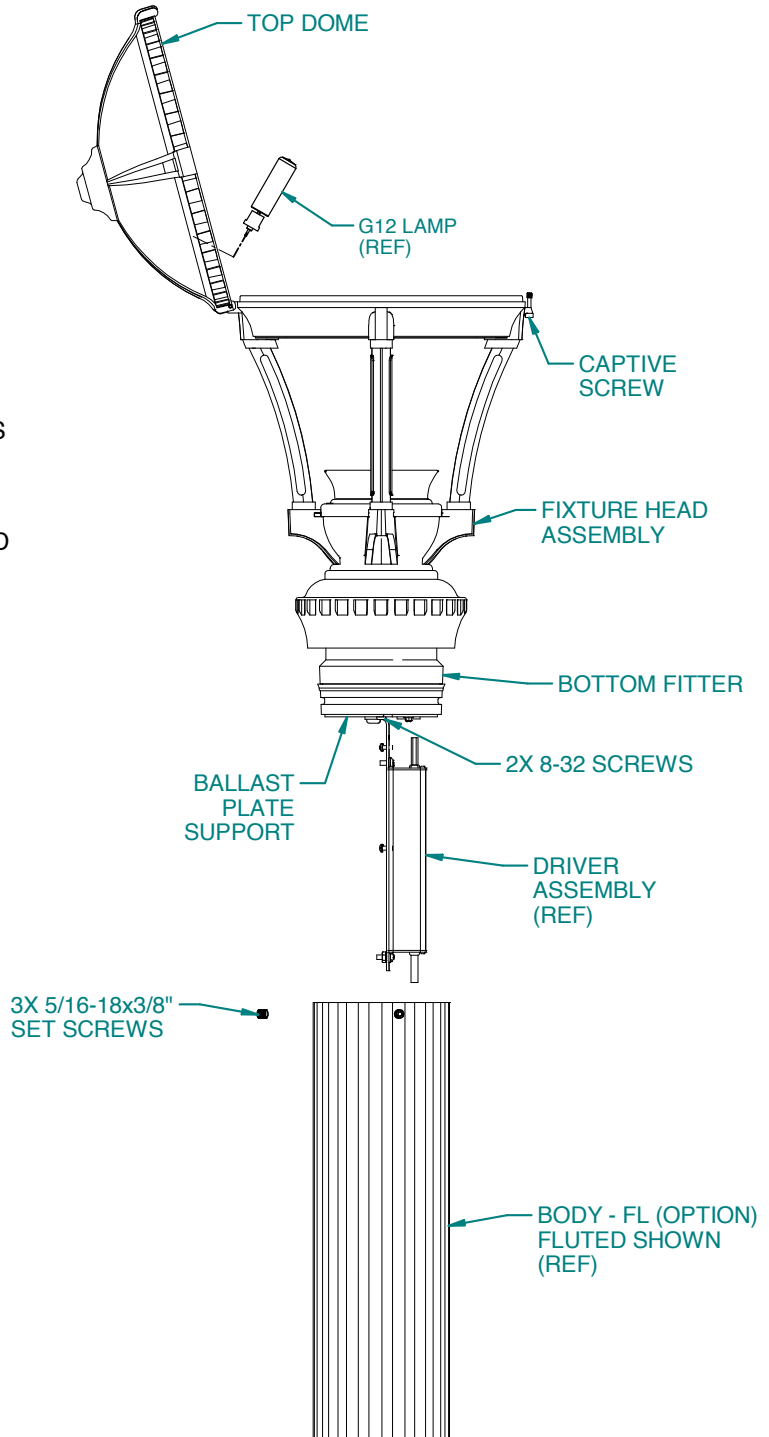

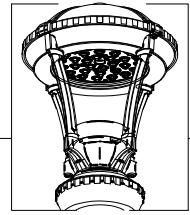

## LED Upgrade Kit Installation Guide

Fixture: PROB™- PROVIDENCE BOLLARD

### STEPS: TO RETROFIT 32YLED

1. REMOVE SCREWS ON EACH SIDE IN LOCATION "A" AND "B". ASSEMBLED LED RETROFIT OPTICAL ASSEMBLY WITH TWO NEW PROVIDED 10-24 SCREWS AND TWO WASHERS AS SHOWN IN THE ILLUSTRATIONS BELOW.
2. TO ASSEMBLE LED DRIVER STRAP ASSEMBLY, FIRST MAKE WIRE CONNECTIONS FROM THE CONDUIT TO LED DRIVER (SEE pg. 6) THEN BY USING TWO 8-32 SCREWS FROM THE BOTTOM FITTER ASSEMBLE LED DRIVER STRAP ASSEMBLY AND SLIGHTLY TWIST CLOCKWISE AND TIGHTEN TWO SCREW.
3. MAKE WIRE CONNECTIONS. FOR WIRING DIAGRAM SEE pg. 6.
4. TURN ON POWER AND CHECK FOR OPERATION.
5. CLOSE TOP DOME AND SECURE WITH CAPTIVE SCREW. RETURN FIXTURE HEAD ASSEMBLY/LED DRIVER STRAP ASSEMBLY TO BODY ASSEMBLY AND SECURE WITH 3X 5/16-18 x 3/8" SET SCREWS.
6. RETROFIT IS COMPLETE.

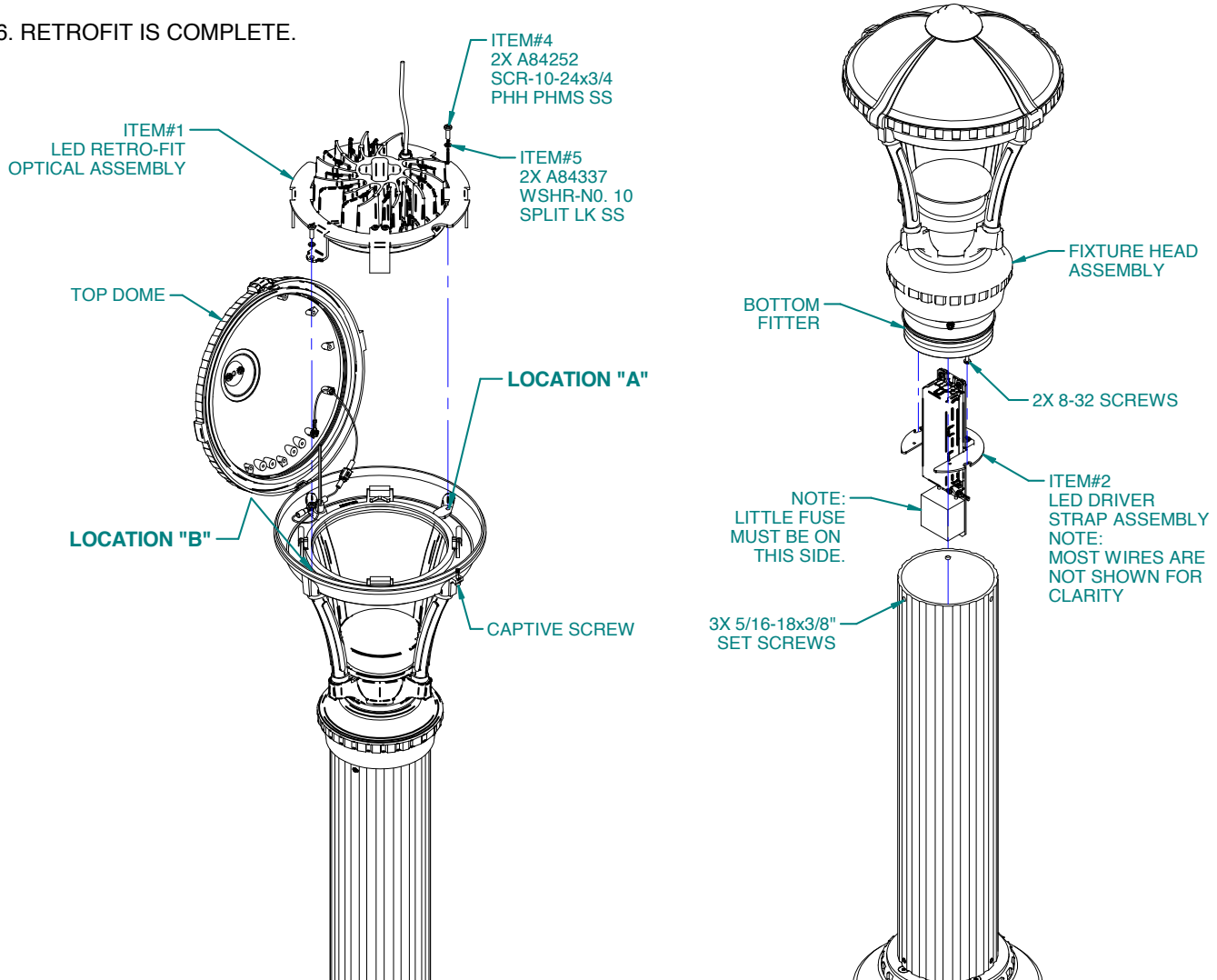

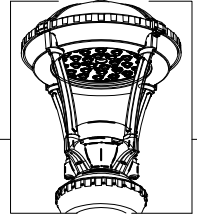

## LED Upgrade Kit Installation Guide

Fixture: PROB™ - PM - PROVIDENCE BOLLARD SEMI RECESSED PIER MOUNT



TURN OFF ALL POWER TO THE UNIT AND TAKE PROPER SAFETY PRECAUTIONS. FAILURE TO DO SO MAY RESULT IN SERIOUS PERSONAL INJURY.

### **STEPS: TO DIS-ASSEMBLE EXISTING ASSEMBLY:**

#### **ACCESS TOP DOME COMPARTMENT**

1. TURN OFF POWER.
2. LOOSEN CAPTIVE SCREW AND LIFT TOP DOME TO ACCESS DOME COMPARTMENT.
3. REMOVE EXISTING OPTICAL SYSTEM IN THE FIXTURE DOME AND DISCARD.

#### **ACCESS DRIVER COMPARTMENT**

1. TURN OFF POWER.
2. REMOVE 3X 5/16-18 X 3/8" SET SCREWS AND REMOVE FIXTURE HEAD ASSEMBLY TO ACCESS DRIVER COMPARTMENT.
3. REMOVE DRIVER ASSEMBLY FROM BOTTOM FITTER BY LOOSENING 2X 8-32 SCREWS AND TWIST COUNTER CLOCKWISE. PULL IT OUT AND DISCONNECT WIRES AND DISCARD

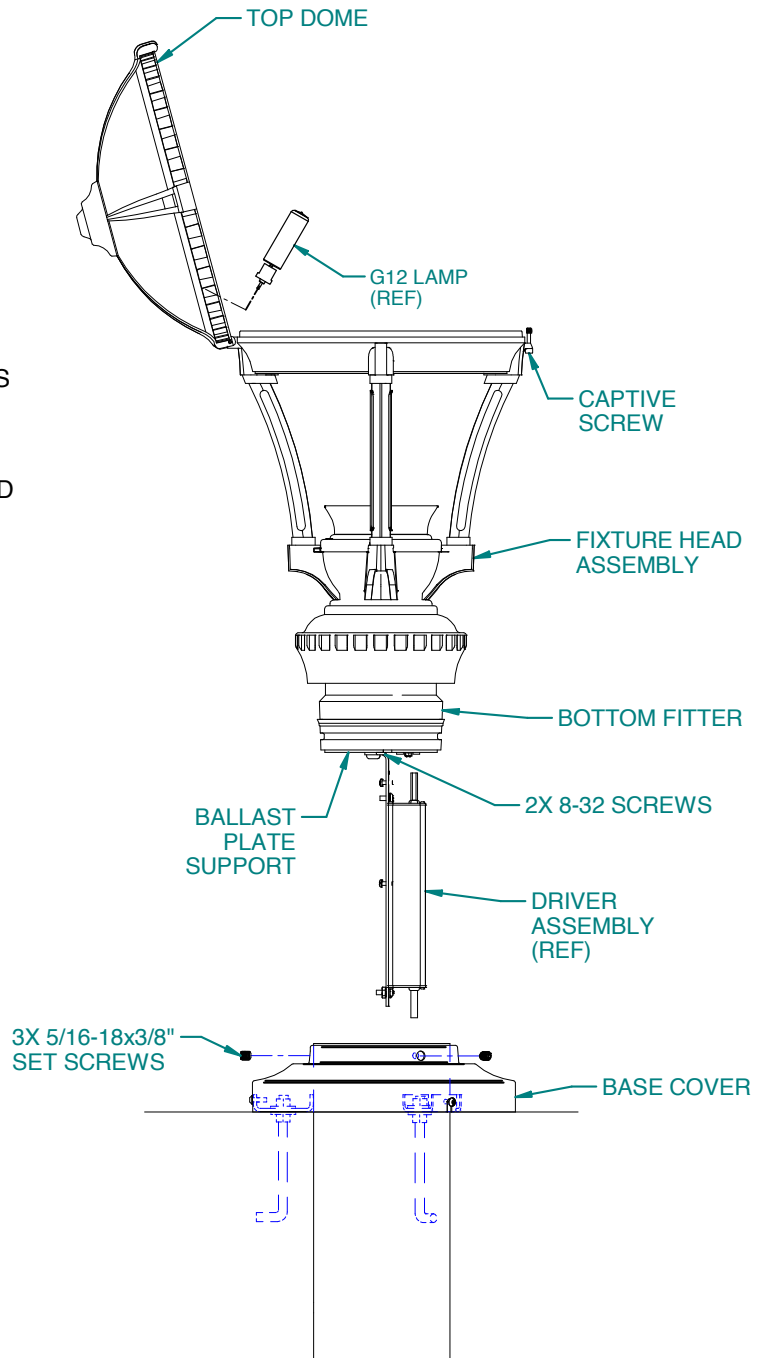

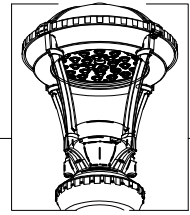

## LED Upgrade Kit Installation Guide

Fixture: PROB™ - PM - PROVIDENCE BOLLARD SEMI RECESSED PIER MOUNT

### STEPS: TO RETROFIT 32YLED

1. REMOVE SCREWS ON EACH SIDE IN LOCATION "A" AND "B". ASSEMBLED LED RETROFIT OPTICAL ASSEMBLY WITH TWO NEW PROVIDED 10-24 SCREWS AND TWO WASHERS AS SHOWN IN THE ILLUSTRATIONS BELOW.
2. TO ASSEMBLE LED DRIVER STRAP ASSEMBLY, FIRST MAKE WIRE CONNECTIONS FROM THE CONDUIT TO LED DRIVER (SEE pg. 6) THEN BY USING TWO 8-32 SCREWS FROM THE BOTTOM FITTER ASSEMBLE LED DRIVER STRAP ASSEMBLY AND SLIGHTLY TWIST CLOCKWISE AND TIGHTEN TWO SCREW.
3. MAKE WIRE CONNECTIONS. FOR WIRING DIAGRAM SEE pg. 6.
4. TURN ON POWER AND CHECK FOR OPERATION.
5. CLOSE TOP DOME AND SECURE WITH CAPTIVE SCREW. RETURN FIXTURE HEAD ASSEMBLY/LED DRIVER STRAP ASSEMBLY TO BODY ASSEMBLY AND SECURE WITH 3X 5/16-18 x 3/8" SET SCREWS.
6. RETROFIT IS COMPLETE.

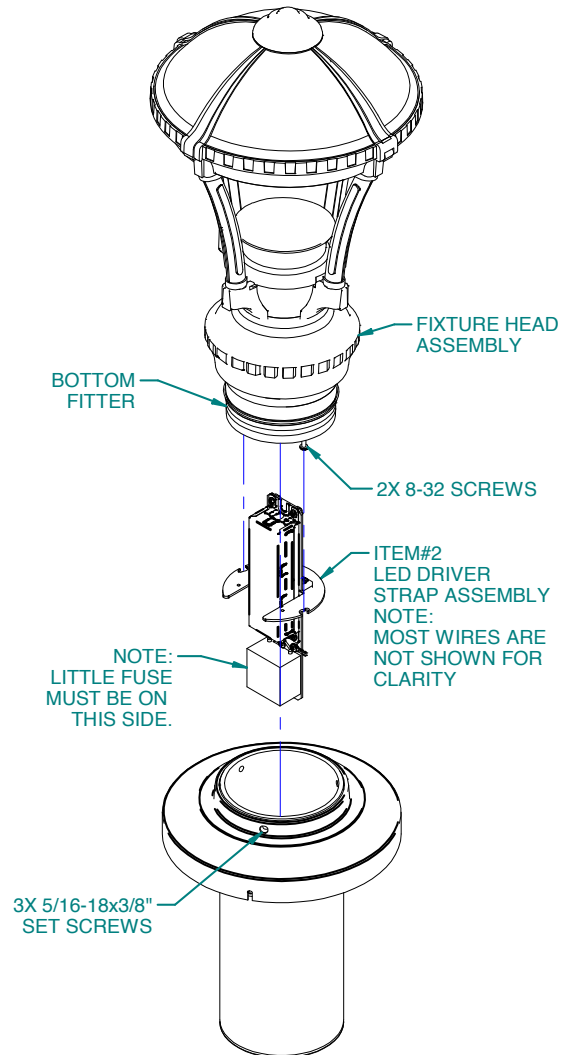
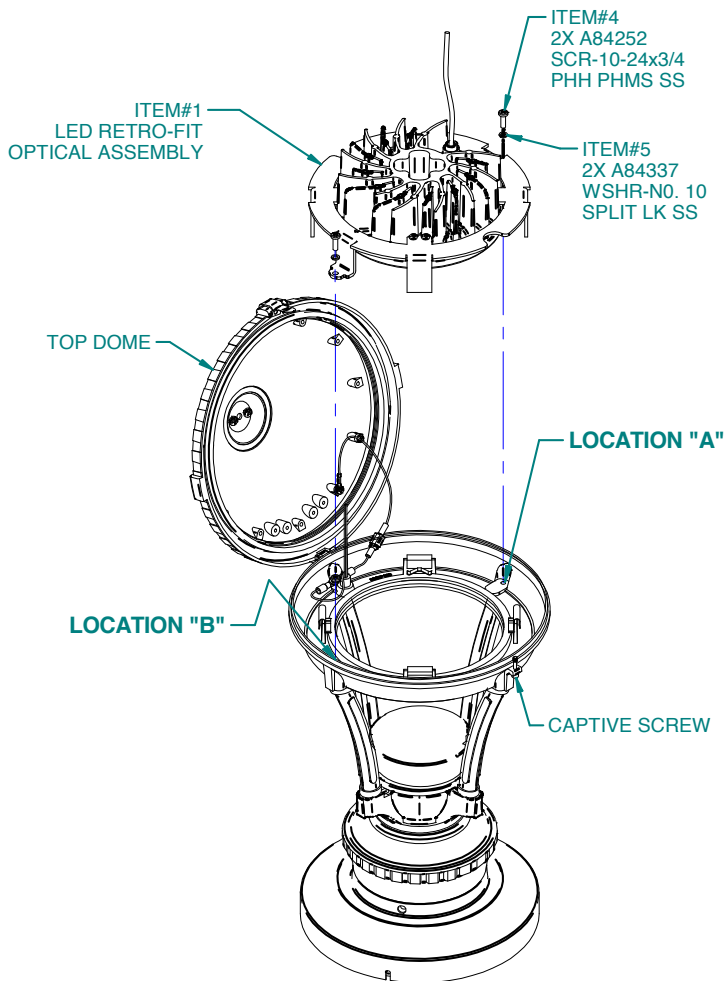

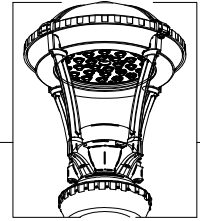

# LED Upgrade Kit Installation Guide

Fixture: PROB™ - PROVIDENCE BOLLARD

## WIRING DIAGRAM

