

OPTION CONNECTIONS

DC REMOTE (-DC) OPTION

IMPORTANT: DC Remote option wires must be run and connected before sign housing is attached to rough-in box. DC Remote option connects to 6-24 volt DC [yellow (-), blue(+)]. Connect option wires (provided) to gray connector on PC board

DUAL CIRCUIT (-2C) OPTION

Dual circuit transformer secondary connection point
NOTE: The larger of the two transformer connectors attaches to the printed circuit board

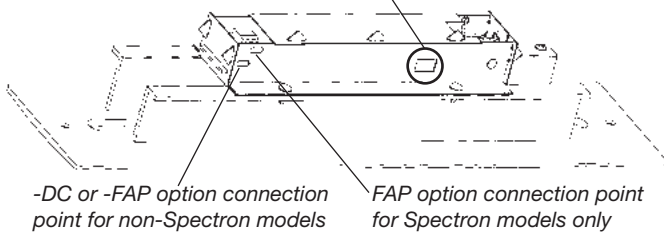

FIRE ALARM PANEL (-FAP) OPTION

IMPORTANT: FAP option wires must be run and connected before sign is attached to rough-in box. FAP option connects to 24 volt AC or DC (purple wires).

Flash Rate: .5 seconds on, .5 seconds off

REVERSING EXIT PLAQUE ASSEMBLY

To reverse plaques on end mounted models

1. Remove one end cap retaining screw
2. Slide plaque out of LED light strip extrusion
3. Rotate plaque
4. Slide plaque into LED light strip extrusion
5. Reinstall end cap

Liteforms®

Collection



LE Series Edge-Lit LED Exit Signs

Installation Instructions



TROUBLE SHOOTING

Exit does not light

- Check wiring connections.
- Transformer secondary connection to LED light strip loose or missing.
- Emergency circuit does not work
- Batteries are shipped uncharged and disconnected. Charge battery before testing.
- Check wiring connections.

MAINTENANCE

Signs should be tested and maintained in accordance with National Electrical Code and NFPA 101 Life Safety Code requirements. It is recommended that emergency exit signs be tested for 30 seconds monthly and for 90 minutes annually.

RECYCLING INFORMATION

All thermoplastic parts are recyclable.
All cartons contain recycled materials.
Please recycle.



NOTICE:

Emergency model exit signs contain rechargeable nickel-cadmium batteries which must be recycled or disposed of properly.



IMPORTANT SAFEGUARDS

When using electrical equipment, basic safety precautions should always be followed including the following:

READ AND FOLLOW ALL SAFETY INSTRUCTIONS

1. Do not use outdoors.
2. Do not mount near heaters or hot surfaces.
3. Equipment should be mounted in locations and at heights where it will not readily be subjected to tampering by unauthorized personnel.
4. The use of accessory equipment not authorized by the manufacturer may cause an unsafe condition.
5. Do not use this equipment for other than its intended purpose.
6. Service of this equipment should be performed by qualified service personnel.

SAVE THESE INSTRUCTIONS

Liteforms LE Series LED Exit Sign Installation Instructions

FINAL ASSEMBLY

1. Plug in unit battery as shown in Fig. 1.
2. Plug in connector from transformer secondary to LED lighting strip as shown in Figures 2, 3 or 4.
3. Mount exit assembly to recessed back box using the trim plate captive screws.

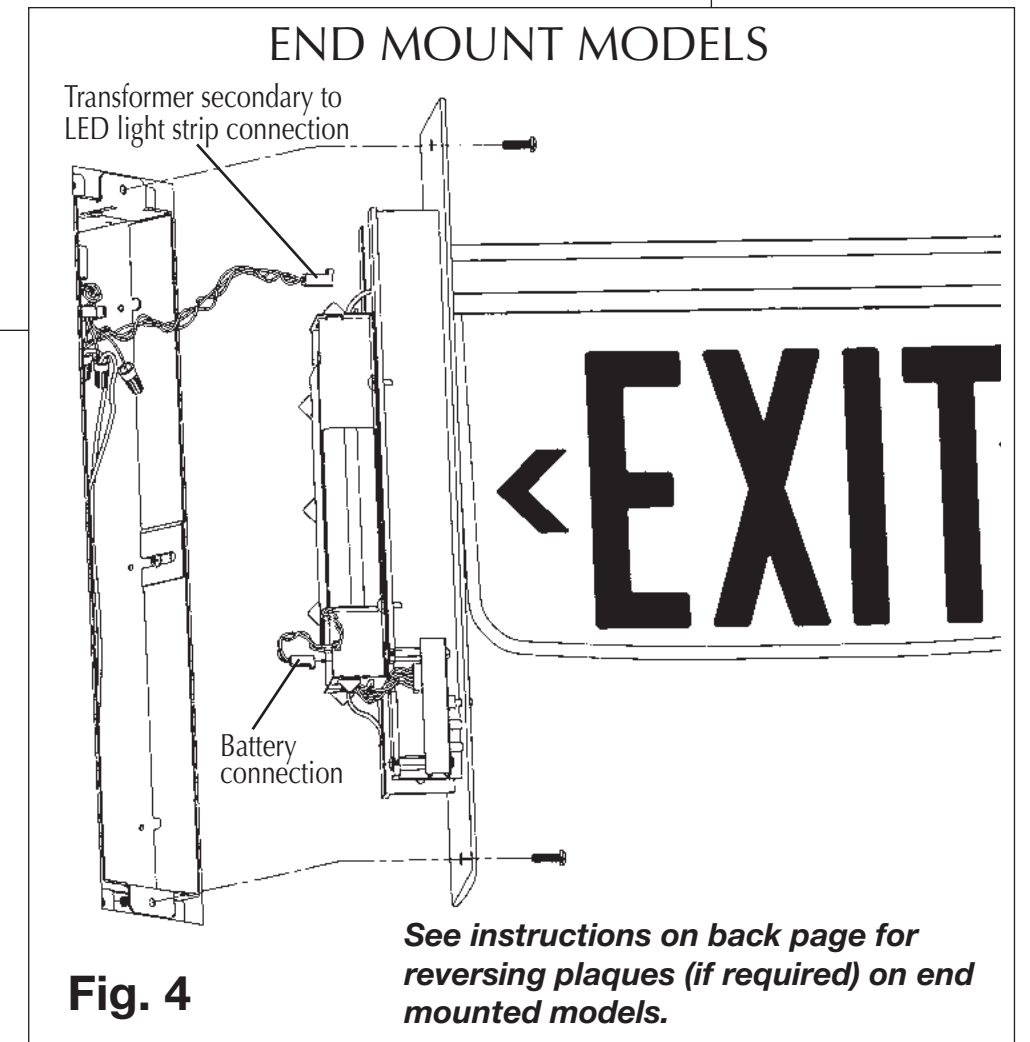
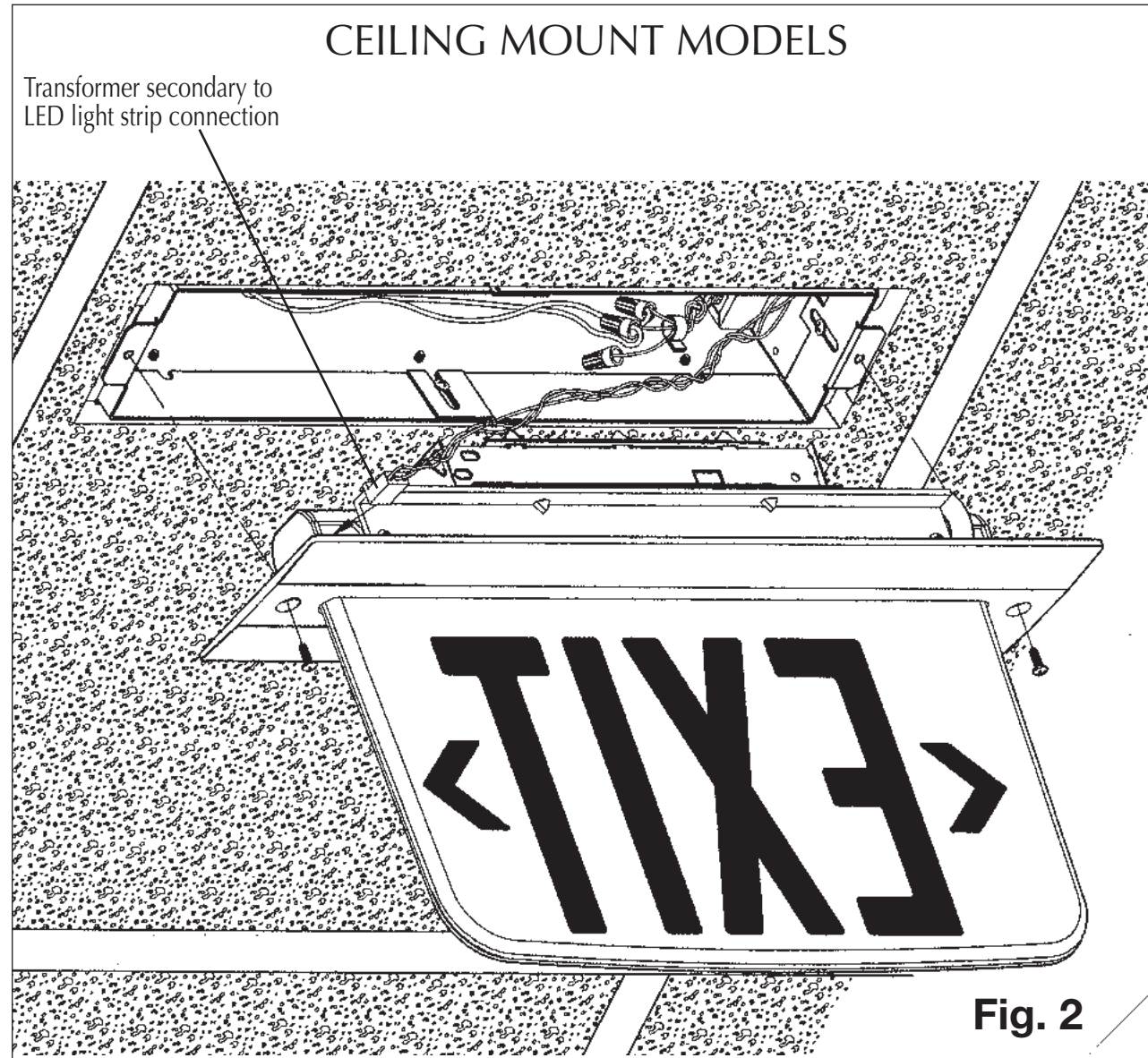
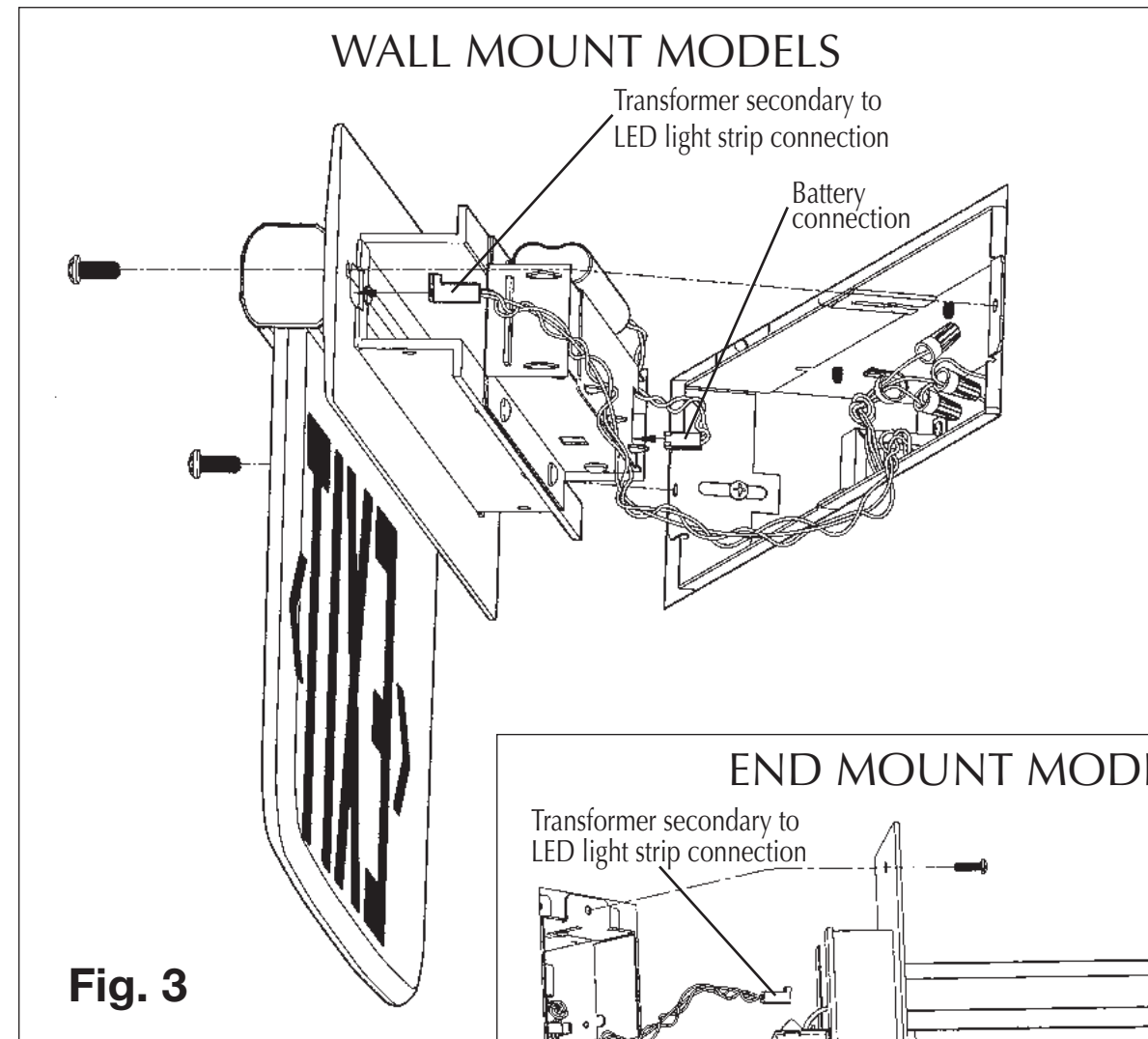
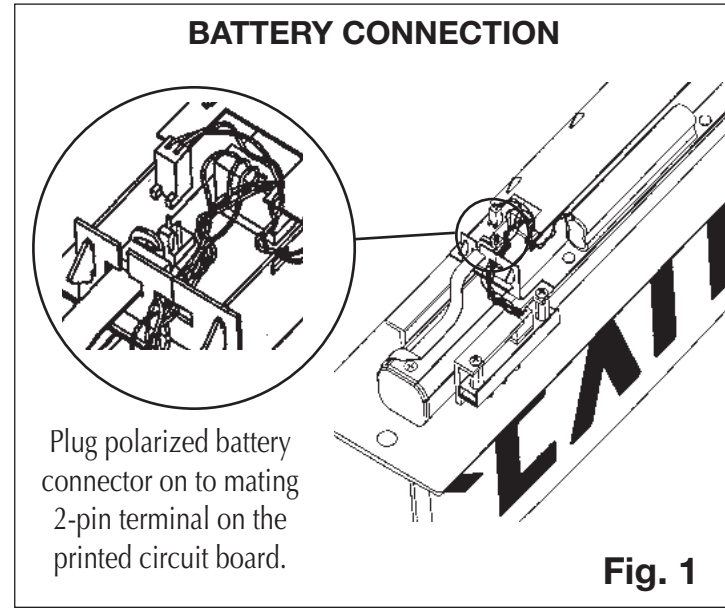

See back page for option information.