

INSTALLING THE VERSABAY® SIDE RAIL, END JAW, WIRE GUARD AND/OR LENS

1) Remove screw on top of end cap side flange at each corner.

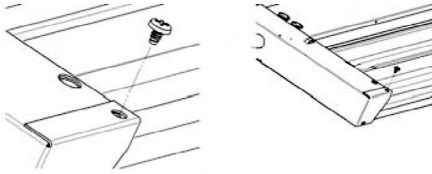

2) Install VersaBay® side rail using the same screw removed in Step 1.

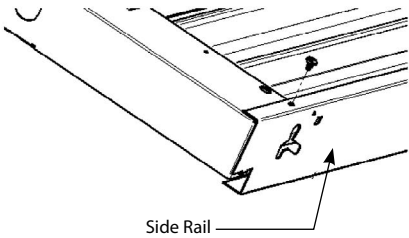

3) Install VersaBay® End Jaw, engaging shoulder rivet in slotted opening in side rails as shown below.

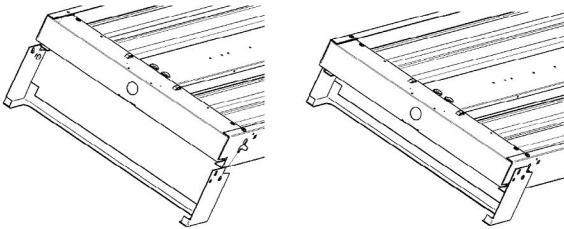

Insert rivet head through keyhole of Jaw pivot track (both sides).

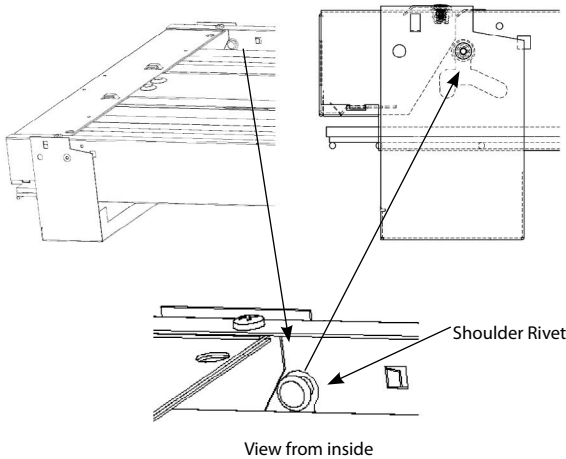

4) Insert Wire Guard & Lens.

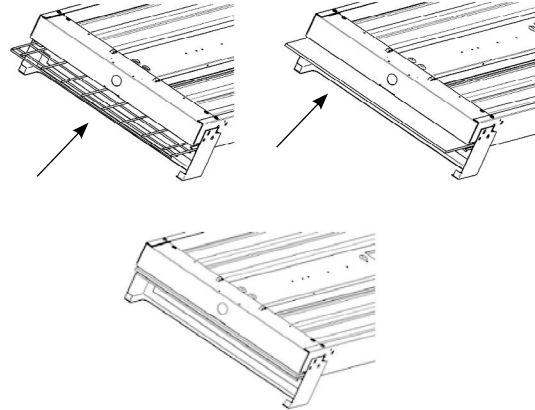

5) Close Jaw by rotating up, lift up & slide Jaw forward install optional security screw (if one is present).

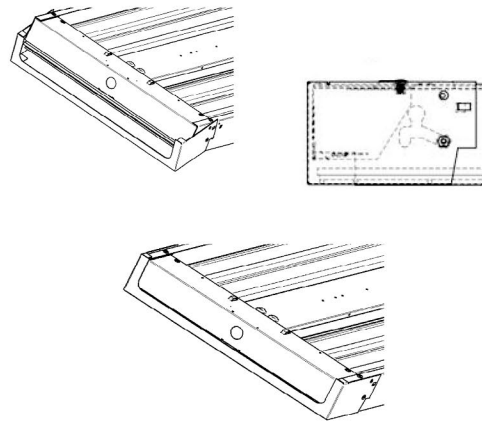

6) Install optional security screw if desired (not provided in kit).

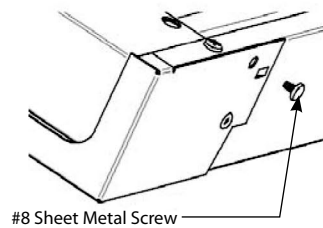

Applies to both fluorescent (shown) and LED VersaBay® High Bays

REMOVING SHIELDING FROM FIXTURES WITH SHIELDING FRAME ALREADY INSTALLED

- 1) Remove optional security screws (if one is present).
- 2) Spread end Jaw side flanges slightly outward away from side rail to disengage locking tab, pull back and up.

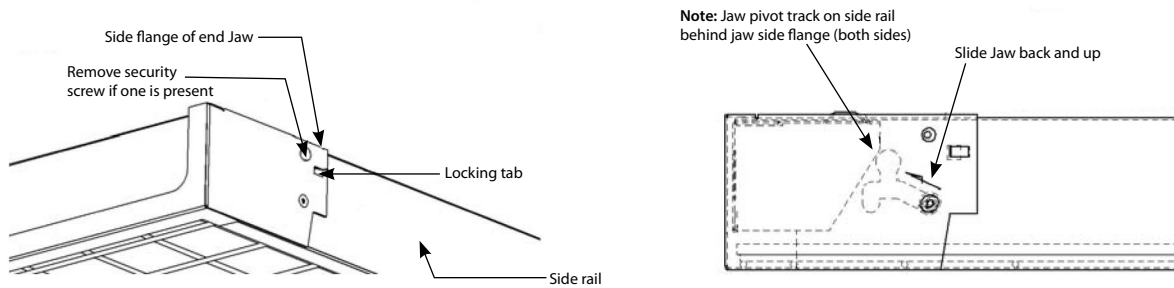

- 3) Continue pulling Jaw back to end of Jaw pivot track and rotate Jaw downward.

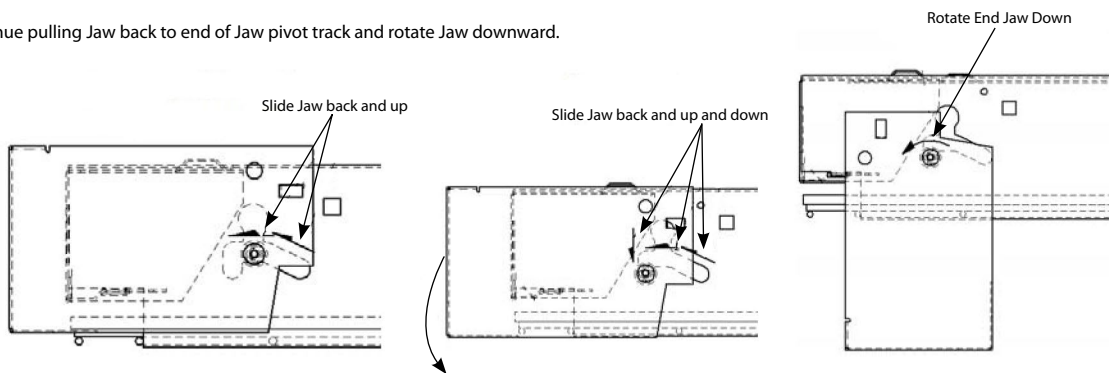

- 4) Slide out lens and/or wire guard

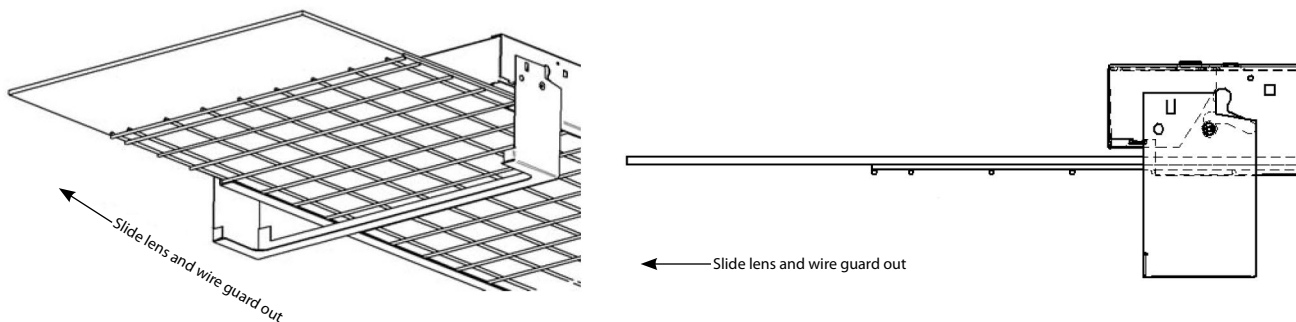

Applies to both fluorescent (shown) and LED VersaBay® High Bays