

Lighting Controls

NXP2 SERIES

NX LIGHTING CONTROL PANEL RELAYS

DATE:	LOCATION:
TYPE:	PROJECT:
CATALOG #:	



FEATURES

- Robust mechanically latching single and double pole relays
- Electrically rated for 60,000+ operations (30,000+ cycles) at full 20a load
- Mechanically rated for 120,000+ operations (60,000+ cycles)
- Short Circuit Current Rating (SCCR) of 18,000A @ 277VAC
- Manual override switch (integral to the relay)
- At-A-Glance ON/OFF relay status indicator
- 5 year limited warranty



Single Pole Relay



Double Pole Relay



SPECIFICATIONS

CONSTRUCTION

- Relay Dimensions
 - Single Pole - L:106.5mm x W:24.5mm x H:60mm
 - Double Pole – L:96mm x W:49.5mm x H:60mm¹

MOUNTING

- Mounts directly to NX Lighting Control Panel relay mounting strap

ELECTRICAL

- Relay Operating Voltages
 - Single Pole (p/n NXP2-RL-SP):
 - General Use: 30A @ 300/347VAC
 - Tungsten: 2400W @ 120VAC
 - (Standard) Ballast: 20A @ 300/347VAC
 - Electronic Ballast: 16A @ 277VAC
 - Motor Starting: ½ HP @ 110-125VAC; 1.5 HP @ 220-277VAC
 - Short Circuit Current Rating (SCCR) of 18,000A @ 277VAC

ELECTRICAL (CONTINUED)

- Double Pole (p/n NXP2-RL-DP):
 - General Use: 20A @ 347/480VAC
 - Tungsten: 2400W @ 120VAC
 - (Standard) Ballast: 20A @ 347/480VAC
 - Motor Starting: ½ HP @ 110-125VAC; 1.5 HP @ 220-277VAC
 - Short Circuit Current Rating (SCCR) of 5,000A @ 277VAC
- Relay Electrical Ratings
 - Rated for minimum 60,000+ operations (30,000+ cycles) at full 20A load
 - Rated full-life with HID load
- Relay Mechanical Ratings
 - Rated for minimum 120,000+ operations (60,000+ cycles)

OPERATION

- Mechanically latching
- Provides at-a-glance indication of ON or OFF relay status

OPERATION (CONTINUED)

- Includes manual override switch (integral to the relay)

OPERATING ENVIRONMENT

- Indoor use only
- 32° to 112°F (0° to 50°C)
- Relative humidity (non-condensing): 10% to 90%

CERTIFICATIONS

- UL Listed
- CSA Approved

WARRANTY

- 5 year limited

Notes:
1 Double pole relays occupy (2) relay spaces.

ORDERING GUIDE

CATALOG #

Example: NXP2-RL-SP

NXP2-RL Model	Type
NXP2-RL NX Lighting Control Panel V2 Relay	SP Single Pole - General Use: 30A @ 300/347VAC; Tungsten: 2400W @ 120VAC; (Standard) Ballast: 20A @ 300/347VAC; Electronic Ballast: 16A @ 277VAC; Motor Starting: ½HP @ 110-125VAC; ½HP @ 220-277VAC DP Double Pole - General Use: 20A @ 347/480VAC; Tungsten: 2400W @ 120VAC; (Standard) Ballast: 20A @ 347/480VAC; Motor Starting: ½ HP @ 110-125VAC; 1.5HP @ 220-277VAC

Lighting Controls

NXP2 SERIES

NX LIGHTING CONTROL PANEL RELAYS

DIMENSIONS

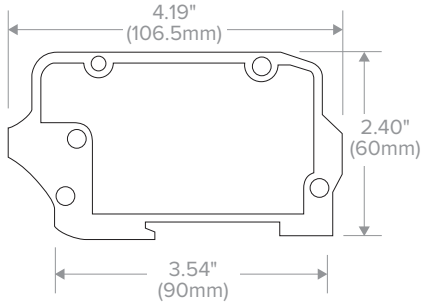
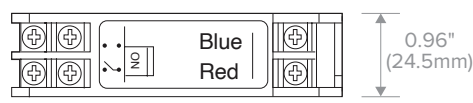

Single Pole Relay

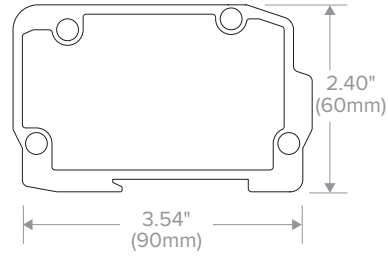
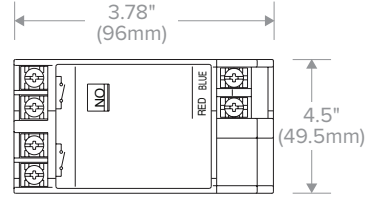

Double Pole Relay

WIRING DIAGRAM

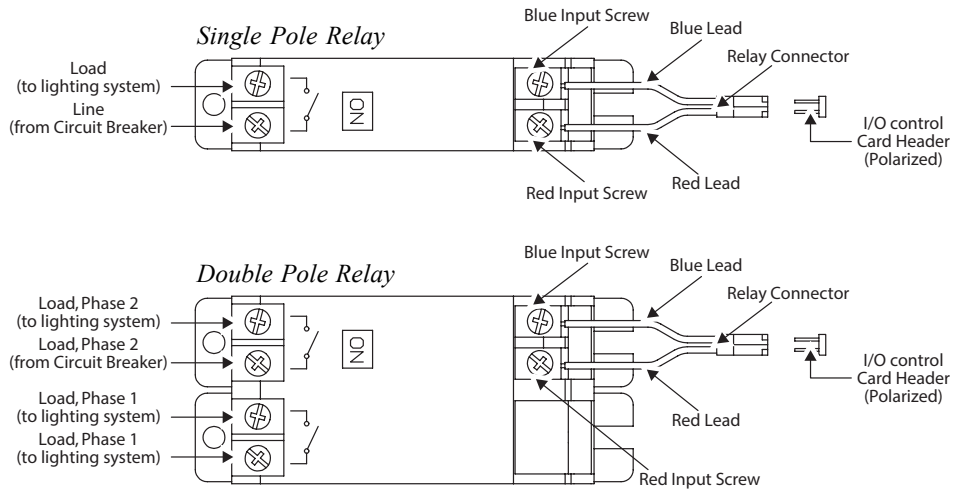

Relay Wiring Diagrams