

# 4090 - Heavy-duty crossarm fitting

FLOODLIGHTING ACCESSORY

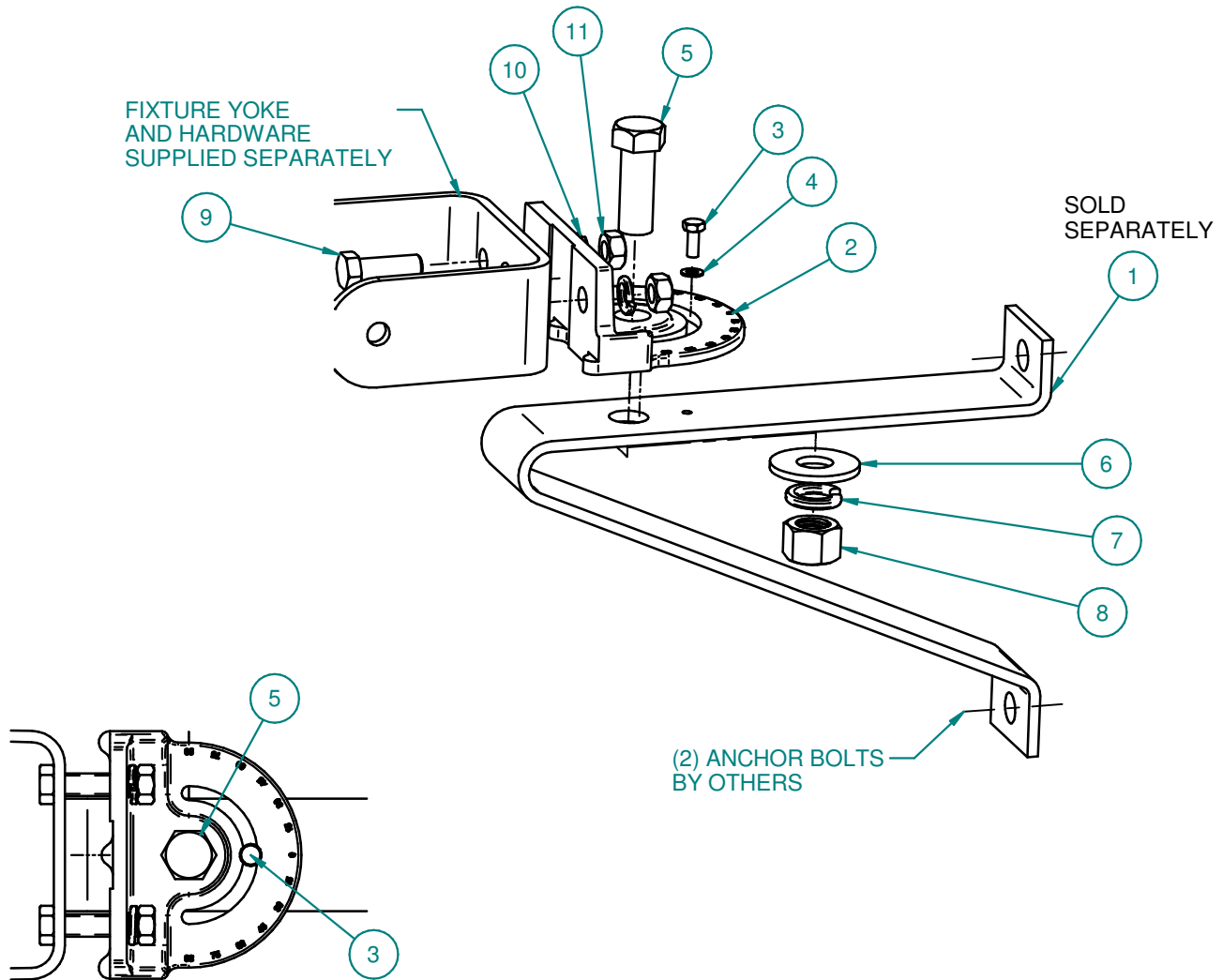

**Warning:** DISCONNECT POWER BEFORE INSTALLATION OR MAINTENANCE



## Mounting Notes:

1. Assemble brackets (1) and (2) with screw (3), split washer (4), screw (5), flat washer (6), split washer (7) and nut (8), as shown above.
2. Secure wall bracket to the wall. Anchor bolts to be supplied by others.
3. Install fixture yoke to bracket with screws (9), split washers (10), and nuts (11). Tighten hex nuts (11) to 50 ft lbs.
4. To adjust fixture angle, loosen screw (3 and 5) and adjust to desired angle. Tighten screws (5) to 130 ft/lbs.
5. Securely tighten screws (3).

## Shipping Package Contents:

4090 Bracket (1)  
Hardware Kit (1):  
1/2-13 Screw (2)  
1/2 Nut (2)  
1/2 Split Washer (2)

**Material:** Steel

**Finish:** Powder Paint

**Weight:** 3 lbs

**Spaulding Lighting**  
701 Millennium Blvd  
Greenville, SC 29607

Technical Support: (864) 678-1000  
Fax: (864) 898-1065  
[www.spauldinglighting.com](http://www.spauldinglighting.com)

Catalog Number: 4090-XX  
Instruction Sheet: 93066060