

4W-P-D

MOD WET 4" LED PENDANT DIRECT

MOD™_W

FEATURES

- Variable Intensity technology provides a range of specifiable outputs and resulting fixture wattages
- 2 SDCM color consistency
- Welded end cap design creates seamless housing appearance
- TriGain® Technology provides superior color quality without compromising efficacy. The 4W-P-D series delivers 90CRI at 134 LPW



CONTROLS TECHNOLOGY



SPECIFICATIONS

CONSTRUCTION

- Housing constructed from extruded aluminum
- End caps constructed from machined aluminum
- End caps welded to aluminum housing for seamless appearance
- Corrosion resistant, extruded aluminum housing with 1000 hour salt spray coverage finish

OPTICAL PERFORMANCE

- 2 SDCM color consistency, 90 CRI
- SOFW: Soft diffuser acrylic lens UV-conditioned meeting UL 1598 standards for UV, water, and temperature resistance

INSTALLATION

- 1/4inch IPS Rigid Stem available in 4ft and 8ft field trimmable options
- All stem kits come standard with 5" canopy matching fixture finish

STEM LOCATIONS

- Stem location at each end of row (including individual fixtures) and at each row joint, see detail on page 5.
- Stems longer than 8' will be coupled together
- All stem lengths are field trimmable (minimum mounting height is 9")

ELECTRICAL

- Variable Intensity (VI) technology allows precise specification of fixture output/wattage. Fixture will be programmed and labeled to specification.
 - LED boards and drivers can be accessed and removed from fixture, while installed
 - Entire LED module can be removed and replaced
 - 1C (1 Circuit) Fixture wired for a single circuit
 - Non-feed: 5" diameter rigid stem canopy
 - Emergency Battery: 10W battery powered driver. Provides a minimum of 90 minutes of emergency lighting. Inverter-Compatible. Provided by others. Available in 4'+ fixtures
 - Current's patented TriGain® phosphor delivers 90 CRI color quality at 80 CRI efficacy
 - Fixture operating ambient temperature range -30°C to 40°C
 - Driver ambient operating temperature range -30°C to 50°C
- ### CONTROLS
- Sensors install in diffusers
 - NX sensor is provided default in white color, for additional color options contact factory
 - NX Lighting Controls provides options for standalone and networked integrated sensor with wireless connectivity for NX system deployments
 - SpectraSync™ Color Tuning Technology: Control your space based on the needs of the application, specific activities throughout

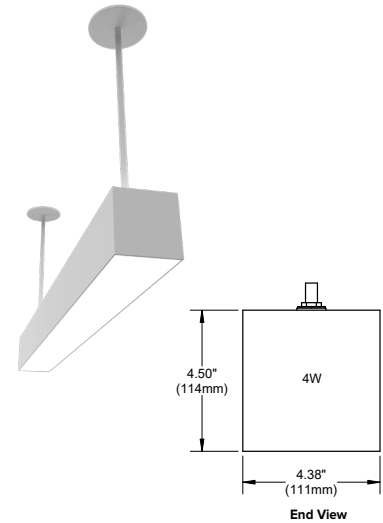

	Weight
4W-P-D	4 lbs/ft

the day and preferences of the occupants

CERTIFICATIONS

- CSA listed for wet location
- IBEW
- AF of L
- UL924
- This product meets federal procurement law requirements under the Buy American Act (FAR 52.225-9) and Trade Agreements Act (FAR 52.225-11). See [Buy America\(n\) Solutions](#).
- Emergency Battery Backup options are California Energy Commission (CEC) Title 20 Compliant.

WARRANTY

- LED boards - 5 years
- LED drivers (standard) - 5 years

KEY DATA	
Lumen Range Per Foot	D030 (300) - D125 (1250)
Wattage Range Per Foot	2.6 - 9.7
Efficacy Range (LPW)	128 - 134
Rated Life (Hours)	L85: >60,000

4W-P-D

MOD WET 4" LED PENDANT DIRECT

ORDERING GUIDE

Example: 4W-P-D-8-08-SOFW-C1-27K9-D030-D01-1C-UNV-PR4

CATALOG # _____

4W	Mounting	Fixture Distribution	Row Length (In Feet)	Max Length In Row	Direct Optical Distribution	Finish/Color
Series 4W MOD Wet	P Pendant	D Direct	___' Enter in foot increments	02 2', 609mm 03 3', 914mm 04 4', 1219mm 05 5', 1524mm 06 6', 1829mm 08 8', 2438mm	SOFW F1 Rated Soft Diffuse Lens, Lambertian	C1 Matte White (Default) C3 Light Silver C5 Carbon Black CC Custom Color ¹
Color Temperature	Direct Output/ft ³	Driver	Circuiting	Voltage	Mounting Kit	
27K9 2700K, 90 CRI ¹ 30K9 3000K, 90 CRI 35K9 3500K, 90 CRI 40K9 4000K, 90 CRI 50K9 5000K, 90 CRI ¹ 2765T 2700K–6500K SpectraSync™ Tunable White ²	D030 300 (min) ⁴ to D125 1250 (max)	D01 1% Dimming, 0–10V D00 1% Dim-to-Off, 0–10V D05 SpectraSync 5% Dimming, 0–10V ⁵ DS1 1% Dimming w/ Soft Start, 0–10V DS0 1% Dim-to-Off w/ Soft Start, 0–10V NDM Non-Dimming LEC 1% Lutron Hi-Lume EcoSystem ^{1,6} DALI DALI ¹ DALIP DALIP ¹ SEN 1% for use with Sensors	1C 1 Circuit	UNV Universal Voltage (120V through 277V) 347 347 Volt ^{1,7}	PR4 4ft Rigid Stem (field trimmable) PR8 8ft Rigid Stem (field trimmable) PR_ Customer Length Rigid Stem (field trimmable) ¹	

OPTIONAL

Nightlight	Emergency	Thru-wiring
NL Nightlight Circuit Required. Enter quantity. 2NL = 2 nightlight circuits/row	EF 10W Emergency Battery Pack. Enter quantity. 2EF = 2 emergency batteries/row. (CEC Title 20 Compliant) ⁸	W1 No Thru Wire W2 Provide Normal and Emergency/ Nightlight Thru Wiring ⁹ W3 Provide Normal Thru Wiring Only

Control Options^{1,10,11}

NX Networked – Wireless

NXWS-12F NX Networked Wireless Enabled Integral NX SMP2-OMNI-O PIR Occupancy Sensor with Automatic Dimming Photocell and Bluetooth Programming

Notes:

- Additional lead time may be applicable. Contact factory.
 - Must be ordered with D05 Driver option; excludes 2' lengths and outputs below D050.
 - Specifiable in 50 lumen increments. Reference the Performance Data Table for full performance offering and exceptions.
 - D030 not available in 2'
 - Must be ordered with 2765T option
 - LEC not available in high ambient applications (over 25°C). D050 is minimum Direct Output for LEC Driver.
 - Excludes Emergency Battery Pack 'EF' Option.
 - EF - 10W battery powered driver. Provides a minimum of 90 minutes of emergency lighting. Inverter compatible; provided by others. For high ambient applications over 25°C with EF (emergency lighting), please contact factory.
 - Only applicable when specified with Emergency/Nightlight.
- NX In-Fixture Control Options:**
- Consult factory for row mounting. Only available with 0–10V Driver options. Contact factory for length restrictions.
 - Refer to NX Integrated Controls Reference Table for Functionality of Options.

4W-P-D

MOD WET 4" LED PENDANT DIRECT



CONTROLS OPTIONS AND FUNCTIONALITY

Control Option Ordering Logic & Description	Control Option Functionality										Control Option Components	
	Sensor	Networkable	Grouping	Scheduling	Occupancy/Motion	Daylight Harvesting	0-10V Dimming	On/Off Control	Bluetooth® App Programming	Sensor Height		
NXWS12F NX Networked Wireless Enabled Integral NXSMP2-OMNI-O PIR Occupancy Sensor with Automatic Dimming Photocell and Bluetooth Programming	✓	✓	✓	✓	✓	✓	✓	✓	✓	✓	12ft	 NXSMP2-OMNI-O

4W-P-D WITH NXWS-12F WIRELESS CONTROL OPTION

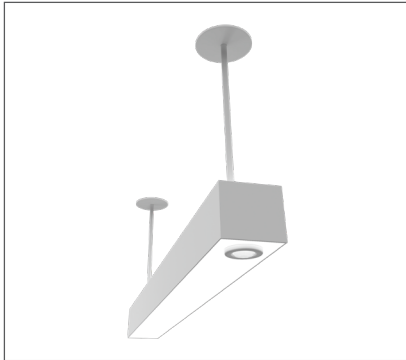

CONTROLS TECHNICAL SUPPORT

1-800-888-8006 (7:00 am–7:00 pm est)

APP INFORMATION

NX Lighting Controls App



The NX Lighting Controls App is a free to use mobile application for programming both an NX Lighting Controls System or Standalone Bluetooth Sensors. The mobile app allows you to configure devices, discover and setup wireless enabled luminaires and program your NX system settings.



Android



Apple iOS

4W-P-D

MOD WET 4" LED PENDANT DIRECT

CONTROLS OPTIONS AND FUNCTIONALITY (CONTINUED)

SpectraSync™ Color Tuning Technology:

Control your space based on the needs of the application, specific activities throughout the day and preferences of the occupants with distinct SpectraSync™ Color Tuning Technologies.



SPECTRASYNC COLOR TUNING TECHNOLOGY		
Mode	Kelvin Range	Description
Tunable White	2700K–6500K	Offers users the ability to tailor CCT to their personal preference, enhancing task visibility, material and colors or the aesthetics of the space
Scheduled White	2700K–6500K	Mimics the rhythm of natural light or follows an alternative user-defined schedule throughout the day, enhancing an occupant's mood and well-being

SpectraSync Tunable White

Available in 2765T (2700K–6500K). Requires two 0–10V controllers, one for intensity and one for CCT. Minimum 5% dimming.

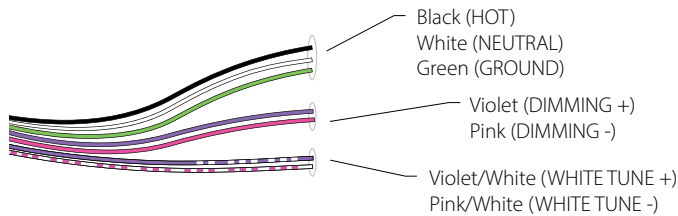

SpectraSync Tunable White luminaires are provided with two 0–10V circuits. The violet and pink circuit is for wiring to any qualified 0–10V controller for dimming. The violet/white and gray/white circuit is for wiring to any qualified 0–10V controller for Tunable White CCT control.

Controller Manufacturer Data

SpectraSync Tunable White was designed to be used with sinking style dimmers (provided by others) and is compatible with:

- Current: NX Lighting Controls Room Controllers (NXRC) and In-fixture Controllers (NXFM)
- Lutron: DTVV, DVSTV, and NFTV dimmers
- Wattstopper: ADF120277 and CD4BL (Titan) dimmers

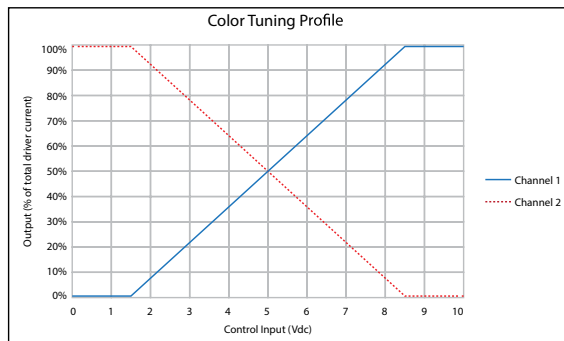

PERFORMANCE DATA TABLE

The table below shows the delivered lumens for the various lumen outputs. Use this chart in connection with the output multiplier capability to deliver any output required.

Nomenclature	Lumens/Ft	W/Ft	Efficacy
Downlight			
D030	300	2.30	130
D050	500	3.73	134
D075	750	5.53	135
D125	1250	9.40	132

(wattage may vary up to 5% from published)

Output Multiplier Table

Photometrics for the MOD Family are published here at a nominal 3500K temperature. This table may be used to approximate the lumen values at different Kelvin temperatures. Power consumption would stay the same.

Option	2700K 90 CRI	3000K 90 CRI	3500K 90 CRI	4000K 90 CRI	5000K 90 CRI
SOFW	0.89	0.96	1.00	1.00	0.99

4W-P-D

MOD WET 4" LED PENDANT DIRECT

DIMENSIONS

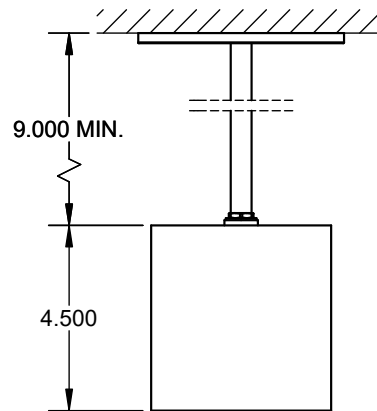
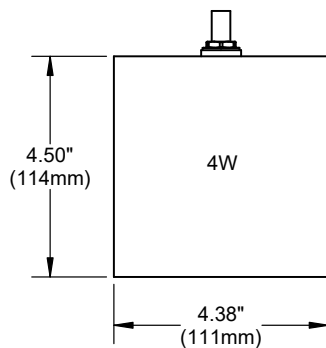
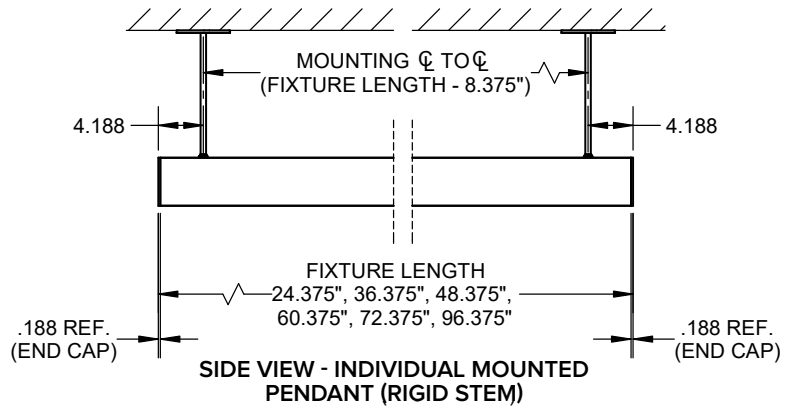
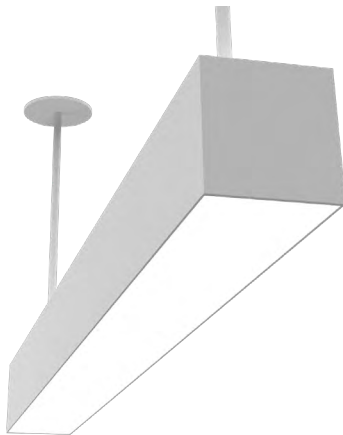
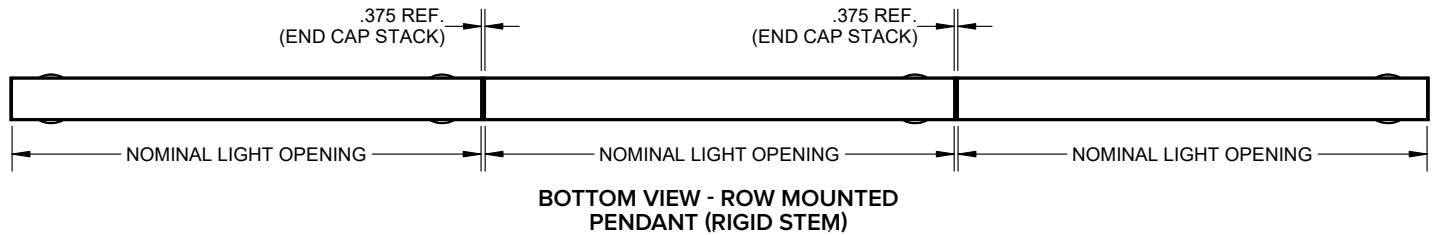
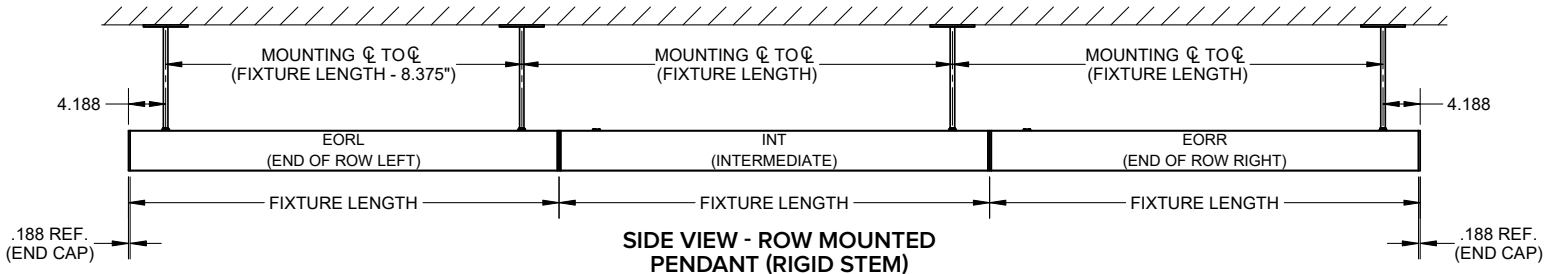

4W-P-D

MOD WET 4" LED PENDANT DIRECT

PHOTOMETRY

4W-P-D-4-SOFW-CX-35K9-D100

LUMINAIRE DATA

Description	MOD 4W Linear Direct
Delivered Lumens	4000
Watts	30
Efficacy	133
Mounting	Pendant

ZONAL LUMEN SUMMARY

Zone	Lumens	% Luminaire
0-40	1840.12	46.00
0-60	3166.13	79.10
0-90	4000.19	100.0
0-180	4000.19	100.0

POLAR GRAPH

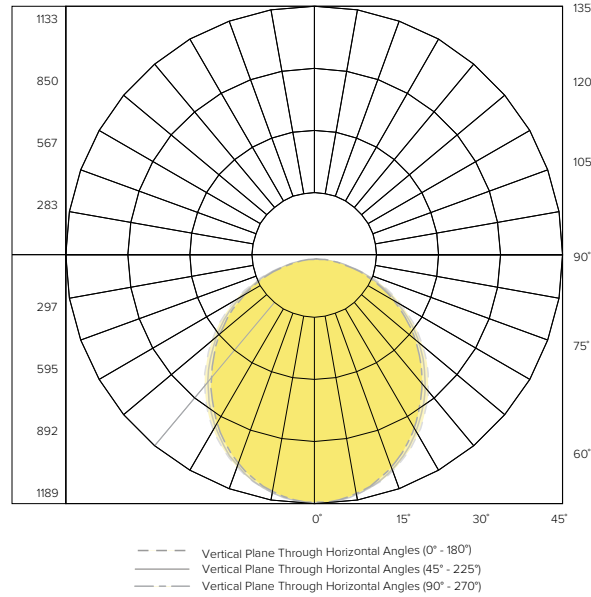

TM-30 DATA

COLOR VECTOR GRAPHIC

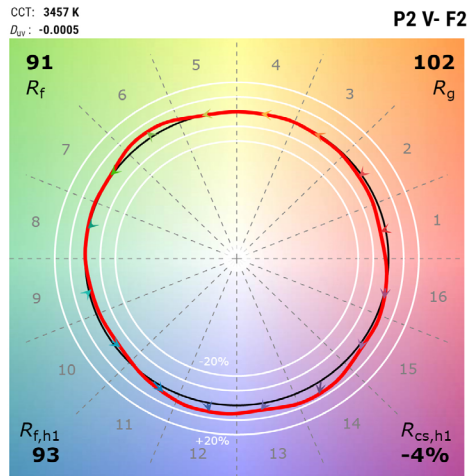

ADDITIONAL INFORMATION

Driver

D01	100%–1% dimming range. Fixture will be wired for low voltage 0–10V dimming control.
D00	Dim-to-Off 100%–1% dimming range. Fixture will be wired for low voltage 0–10V dimming control.
D05	100%–5% dimming range. Fixture will be wired for low voltage 0–10V dimming control. Only applicable if either 2230TD, 2750T or 2765T is selected.
DS1	Soft-Start 100%–1% dimming range. Fixture will be wired for low voltage 0–10V dimming control.
DS0	Soft-Start Dim-to-Off 100%–1% dimming range. Fixture will be wired for low voltage 0–10V dimming control.
NDM	Non-dimming. Fixture will be wired for fixed light output.

Rated Life

Tested in accordance to ANSI/IES TM-21-21

L70: >60,000 (reported per TM-21/LM80 6x's limitation)

L90: >50,000 (reported per TM-21/LM80 6x's limitation)

For reference only, tested in accordance to LM79-2008 & extrapolated from EPA TM-21 calculator

L70: 280,000

L90: 72,000

Rated Life (Driver)

Standard = 100,000 hours