

# ARM-CRD-6-S - Square Pole Arm

CIMARRON ACCESSORY

**WARNING:** To avoid damaging supply wiring, drill all necessary holes in poles, arms, or mounting brackets BEFORE pulling supply wires.

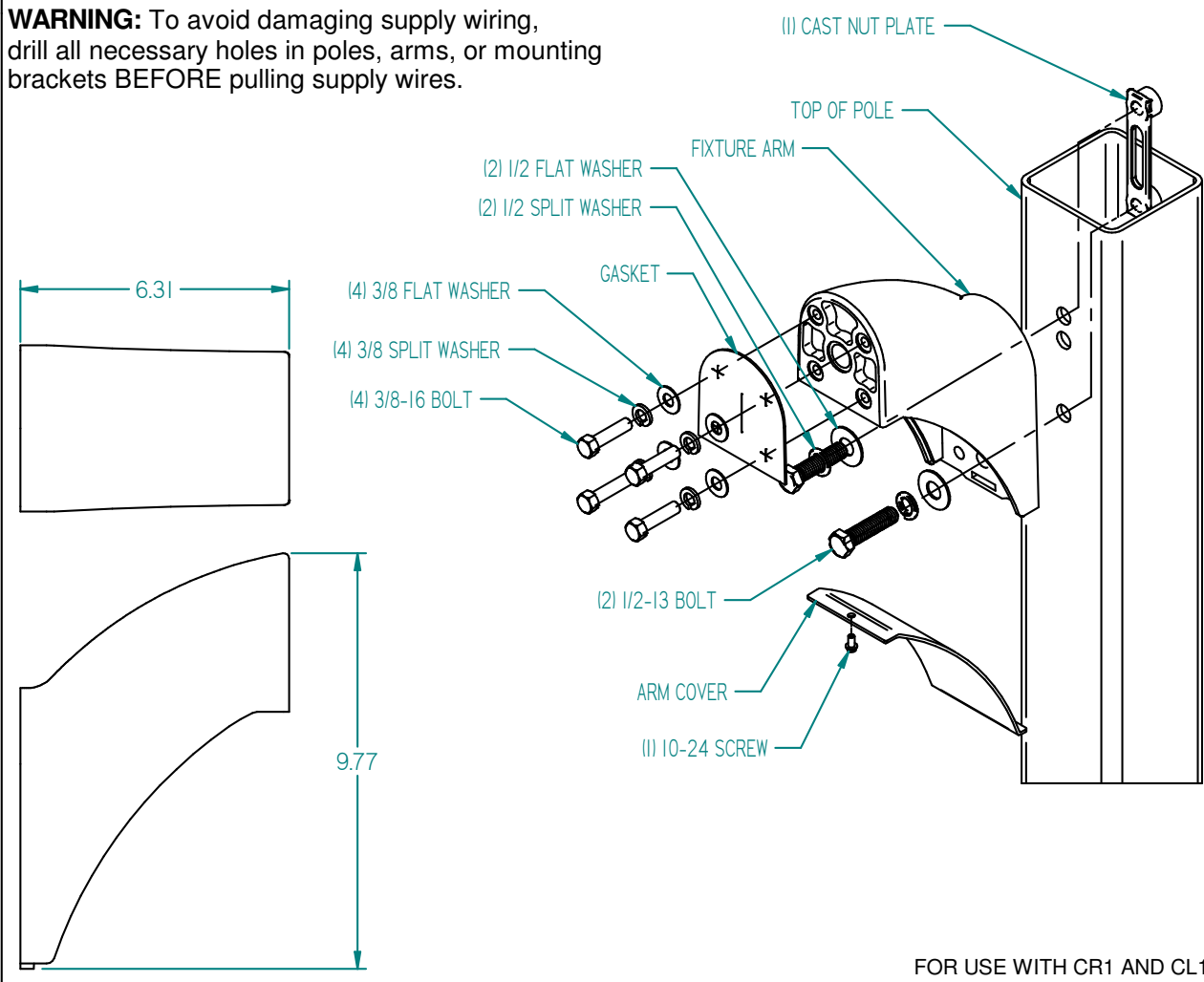

**Mounting Notes:**

1. Position arm to pole and hole pattern aligned to pre-drilled holes in pole.
2. Position nut plate (supplied with fixture) inside pole to line up with arm.
3. Consulting fixture instructions, install (2) 1/2-13 bolts, through (2) flat washers, (2) split washers, then through the two 0.57" holes in the arm to secure to pole. Tighten to 35-40 ft-lbs torque.
4. Apply gasket to arm end.
5. Align mounting holes on fixture to holes in gasket.
6. Install (4) 3/8-16 bolts, (4) 3/8 split washers, (4) 3/8 flat washers through mounting holes, on inside of fixture, and secure to arm. Tighten to 15-20 ft-lbs torque.

**Shipping Package Contents:**

- Fixture arm (1)
- Nut Plate (1)
- Arm cover (1)
- 10-24 Screw (1)
- 1/2-13X2in bolt (2)
- 1/2 Split washer (2)
- 1/2 Flat Washer (2)
- Arm gasket (1)
- 3/8-16 bolt (4)
- 3/8 Flat Washer (4)
- 3/8 Split Washer (4)

**Material:** Aluminum  
**Finish:** Powder Paint  
**Weight:** 8 lbs