

DATE: _____ LOCATION: _____
 TYPE: _____ PROJECT: _____
 CATALOG #: _____



FEATURES

- Designed for light industrial and multi-purpose areas including gyms, schools, churches and retail spaces
- Five reflector and three lens options for shielding variety
- Standard and high efficacy versions available
- Replaces 250W/400W HID high bays
- Ambient operation up to 65°C; see table provided for details
- Enhanced control options with NX Lighting Controls



CONTROL TECHNOLOGY



SPECIFICATIONS

CONSTRUCTION

- Housing: Die-Cast Aluminum
- Pendant mount installation from 3/4" threaded conduit or fixture hook
- Symmetrical design for easy one-for-one replacement of existing high bays
- Weight: 15 lbs.

OPTICS

- Available in 12,000, 18,000 and 24,000 lumen packages to replace 175W, 250W and 400W HID
- Up to 162 LPW

SHIELDING (16" Diameter Reflectors)

- Clear Acrylic
- Translucent White
- Opalescent Acrylic
- Suspended Bead
- Anodized Aluminum

ELECTRICAL

- 0-10V standard with dimming range 100% to 10%
- 120-277V standard; optional 347V or 480V

CONTROLS

- NX Lighting Controls provides options for standalone and networked integrated sensor with wired or wireless connectivity for NX system deployments
- NX is available in U.S., Canada and Mexico. For other locations consult factory

CERTIFICATIONS

- Tested to CSA standards for UL 1598 Damp Location
- Emergency equipped fixtures labeled UL 924
- DLC® (DesignLights Consortium) Qualified, with some Premium Qualified configurations. Please refer to the DLC website for specific product qualifications at www.designlights.org
- The DTS, Dimming Bypass Module, is for emergency circuit control loads including sensors and wireless systems listed to UL 924. See page 7 for wiring diagram.

WARRANTY

- 5 year warranty

KEY DATA	
Lumen Range	12,000–30,000
Wattage Range	84–190
Efficacy Range (LPW)	106–162
Reported Life (Hours)	L80/60,000

DATE: _____ LOCATION: _____
 TYPE: _____ PROJECT: _____
 CATALOG #: _____

ORDERING GUIDE

Example: UTB2-730-LX-ED1-WA16-DLR-WH-C6HLP115A

CATALOG # _____

UTB	2	ED
Series	Generation	Voltage
UTB High Bay	2 2	U 120 - 277 ¹
	7 >70	1 120V
	8 >80	2 208V
	9 >90	3 240V
		4 277V
		F 347V
		5 480V
		ED 0-10V dimming to 10%
	30 3000K	LX 12,000
	35 3500K	LXHE 12,000
	40 4000K	MM 18,000
	50 5000K	MMHE 18,000
		MH 24,000
		MHHE 24,000
		MVHE 30,000

Optic	Lens	Color	Options
WA16 Clear Acrylic 16"	N None	BL Black	C(y)HLP(x)(z) Cord, Hook, Loop & Plug ^{2,3,4}
WW16 Translucent White 16"	CDL Conical Drop Lens	GR Gray	C4H 4' Cord w/ Hook/Loop ⁴
OP16 Opalescent Acrylic 16"	DLR Dropped Lens Refractor	WH White	C6HL 6' Cord w/ Hook/Loop ⁴
SB16 Suspended Bead 16"	P95 Frosted Acrylic Lens	CC Custom Color	C8HL 8' Cord w/ Hook/Loop ⁴
AL16 Anodized Aluminum 16"			C10HL 10' Cord w/ Hook/Loop ⁴
N No Optic			C12HL 12' Cord w/ Hook/Loop ⁴
			CGS Clear Glass LED Shield
			ELL14 Emergency Backup, 1400 Lumens (BSL310SB) ^{5,6}
			F(x) Fusing ^{2,6}
			DTS Dimming Transfer Module ^{7,8}
			SP 10KV Surge protector (voltage specific)

Control Options

NX Wired

NXEHM NX Wired Dual RJ45 SmartPORTs and Integral NXSMP2-HMO PIR Occupancy Sensor with Automatic Dimming Photocell and Bluetooth Programming

NX Wireless

NXW NX Networked Wireless Radio Module NXRM2 and Bluetooth Programming, without Sensor

NXWLM NX Networked Wireless Enabled Integral NXSMP2-LMO PIR Occupancy Sensor with Automatic Dimming Photocell and Bluetooth Programming

Sensor Controls

SCL On/Off Occ. Sensor, Low Voltage, 1:25 Mounting Height to Coverage Ratio^{6,9,11}

SCD Dim. Occ. Sensor, Line Voltage, 1:25 Mounting Height to Coverage Ratio^{6,9,11}

Accessories

- UTBFWG** Wire Guard - Full Cage
- UTBWGD** Wire Guard - Full Cage with Deep Lens Bottom Cover for CDL or DLR Lens option
- UTBFWGS** Wireguard - Full Cage with Shallow lens bottom cover for P95 Lens option
- UTB-TLR** Luminaire Retainer

Notes:

- 1 Not available with voltage specific cord or fuse options.
- 2 Replace (X) with the voltage, 1=120V, 2=208V, 3=240V, 4=277V, F= 347V, 5=480V.
- 3 Replace (Y) with the length. 4=4ft, 6=6ft, 8=8ft., 10=10ft., 12=12ft. Replace (Z) with 15A or 20A.
- 4 3 wire (line voltage) cord standard; for 5 wire (line + low voltage) cord configurations please contact factory
- 5 ELL14 Not available with Fusing - F(x) or Surge Protector - SP
- 6 Not available with 347V or 480V
- 7 For emergency circuit control loads including sensors and wireless systems listed to UL924. Universal Voltage Only. See page 7 for wiring diagram
- 8 Consult factory for available configurations
- 9 Not available with any other control options.
- 10 Not available with 480V
- 11 Not available with N - No Optic

DATE:	LOCATION:
TYPE:	PROJECT:
CATALOG #:	

CONTROLS

NX Lighting Controls:

Supports indoor and outdoor applications, wired, wireless and hybrid networked NX lighting control deployments and enables emerging applications such as Current's SpectraSync™ color tuning technology.



NX INTEGRATED CONTROLS REFERENCE									
NX Option	Sensor	Category	Networkable	Scheduling	Occupancy	Daylight Harvesting	0-10V Dimming	On/off Control	Bluetooth App Programming
NXEHM	NXSMP2-HMO	Networked Wired	Yes	Yes	Yes	Yes	Yes	Yes	Yes
NXW	N/A	Networked Wireless	Yes	Yes	No	No	Yes	Yes	Requires NX Bluetooth® Radio Module
NXWLM	NXSMP2-HMO	Networked Wireless	Yes	Yes	Yes	Yes	Yes	Yes	Yes

See separate NX™ Application Guide for additional details.
See Current Controls NX Brochure.

DELIVERED LUMENS

	REFLECTOR	BOTTOM LENS	LX	WATTS	LM/W	LXHE	WATTS	LM/W	MM	WATTS	LM/W	MMHE	WATTS	LM/W	MH	WATTS	LM/W	MMHE	WATTS	LM/W
No Glass Lenses	N	N	13126	84	156	13144	76	172	19390	128	151	19663	119	165	25700	168	153	25993	160	162
	WA16	N	12751	84	151	12764	76	167	18846	128	148	19100	119	161	24966	168	149	25259	160	158
		CDL	11940	84	142	11950	76	157	17823	128	140	17885	119	150	23377	168	140	23652	160	148
		DLR	11415	84	135	11427	76	150	16872	128	132	17101	119	144	22352	168	133	22615	160	141
		P95	11997	84	142	12008	76	157	17730	128	139	17971	119	151	23488	168	140	23765	160	148
	WW16	N	11822	84	140	11834	76	155	17472	128	137	17709	119	149	23146	168	138	23417	160	146
		CDL	10814	84	128	10825	76	142	15982	128	125	16199	119	136	21172	168	126	21422	160	134
		DLR	10215	84	121	10225	76	134	15097	128	118	15302	119	129	20000	168	119	20235	160	126
	OP16	P95	10934	84	130	10943	76	143	16158	128	127	16376	119	138	21405	168	128	21657	160	135
		N	12729	84	151	12741	76	167	18813	128	148	19068	119	160	24922	168	149	25215	160	157
		CDL	12028	84	143	12039	76	158	17776	128	139	18017	119	151	23550	168	141	23826	160	149
	SB16	DLR	11588	84	138	11599	76	152	17127	128	134	17358	119	146	22690	168	135	22955	160	143
		P95	12074	84	143	12086	76	158	17846	128	140	18087	119	152	23641	168	141	23918	160	149
		N	12820	84	152	12833	76	168	18948	128	149	19089	119	160	25103	168	150	25397	160	159
		CDL	12113	84	144	12125	76	159	17903	128	140	18144	119	152	23716	168	142	23995	160	150
	AL16	DLR	11602	84	137	11613	76	152	17147	128	134	17380	119	146	22715	168	136	22982	160	144
		P95	12148	84	144	12159	76	159	17955	128	141	18198	116	157	23785	168	142	24064	160	150
		N	10874	84	129	10885	76	143	16074	128	126	16291	119	137	21292	168	127	21542	160	135
		CDL	9759	84	116	9769	76	128	14426	128	113	14621	119	123	19110	168	114	19333	160	121
	AL16	DLR	8924	84	106	8933	76	117	13191	128	103	13370	119	112	17473	168	104	17679	160	110
P95		9623	84	114	9633	76	126	14224	128	112	14416	119	121	18842	168	112	19062	160	119	

DELIVERED LUMENS (CONTINUED)

	REFLECTOR	BOTTOM LENS	LX	WATTS	LM/W	LXHE	WATTS	LM/W	MM	WATTS	LM/W	MMHE	WATTS	LM/W	MH	WATTS	LM/W	MMHE	WATTS	LM/W
Glass Lens CGS	N	N	11975	84	142	11987	76	157	17699	128	139	17938	119	151	23446	168	140	23722	160	148
	WA16	N	11629	84	138	11641	76	153	17188	128	135	17418	119	146	22769	168	136	23036	160	144
		CDL	10889	84	129	10998	76	144	16093	128	126	16311	119	137	21320	168	127	21570	160	135
		DLR	10411	84	124	10422	76	137	15388	128	121	15595	119	131	20385	168	122	20625	160	129
		P95	10940	84	130	10952	76	144	16170	128	127	16389	119	138	21422	168	128	21675	160	135
		N	10781	84	128	10792	76	141	15935	128	125	16150	119	136	21110	168	126	21357	160	133
	WW16	CDL	9861	84	117	9872	76	129	14576	128	114	14773	119	124	19310	168	115	19536	160	122
		DLR	9316	84	111	9325	76	122	13769	128	108	13955	119	117	18240	168	109	18455	160	115
		P95	9970	84	118	9980	76	131	14736	128	116	14935	119	126	19521	168	117	19751	160	123
		N	11609	84	138	11620	76	152	17158	128	135	17389	119	146	22730	168	136	22996	160	144
	OP16	CDL	10968	84	130	10980	76	144	16211	128	127	16432	119	138	21478	168	128	21730	160	136
		DLR	10568	84	125	10579	76	139	15620	128	123	15831	119	133	20693	168	124	20936	160	131
		P95	11011	84	131	11022	76	144	16275	128	128	16494	119	139	21560	168	129	21814	160	136
		N	11692	84	139	11704	76	153	17281	128	136	17514	119	147	22893	168	137	23162	160	145
	SB16	CDL	11046	84	131	11059	76	145	16328	128	128	16548	119	139	21629	168	129	21883	160	137
		DLR	10580	84	125	10590	76	139	15638	128	123	15850	119	133	20717	168	124	20960	160	131
		P95	11078	84	131	11089	76	145	16375	128	128	16596	119	139	21692	168	130	21947	160	137
		N	9918	84	117	9928	76	130	14658	128	115	14856	119	125	19418	168	116	19647	160	123
	AL16	CDL	8901	84	106	8910	76	117	13156	128	103	13333	119	112	17428	168	104	17633	160	110
		DLR	8139	84	96	8147	76	107	12029	128	94	12192	119	102	15937	168	95	16124	160	101
		P95	8777	84	104	8785	76	115	12971	128	102	13147	119	110	17184	168	103	17386	160	109

PHOTOMETRY

UTB2-8-50-MHHE-WW-X-AL16-N-YY-ZZZZ

LUMINAIRE DATA

Test No.	20867
Description	UTB2 High Bay with Open-Bottom AL16 Reflector
Delivered Lumens	21,542
Watts	160.1W
Efficacy	135
Mounting	Pendant
Spacing Criterion	(0-90) 1.10

ZONAL LUMEN SUMMARY

Zone	Lumens	% Luminaire
0-30	12,609	58.5
0-40	18,603	86.4
0-60	21,185	98.3
0-90	21,492	100.0
0-180	21,542	100.0

POLAR GRAPH

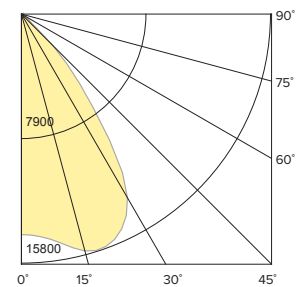

PHOTOMETRY (CONTINUED)

UTB2-8-50-MHHE-WW-X-N-N-YY-ZZZZ

LUMINAIRE DATA

Test No.	20849
Description	UTB2 High Bay with No Enclosure or Reflector
Delivered Lumens	25,993
Watts	160.08W
Efficacy	162
Mounting	Pendant
Spacing Criterion	1.29

ZONAL LUMEN SUMMARY

Zone	Lumens	% Luminaire
0-30	7028	27
0-40	11,620	44.7
0-60	20,974	80.7
0-90	25,993	100
0-180	25,993	100

POLAR GRAPH

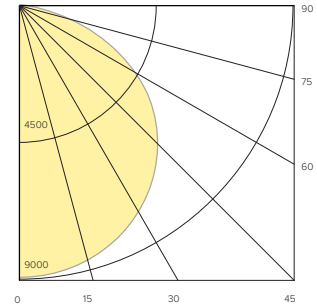

UTB2-8-50-MHHE-WW-X-OP16-N-YY-ZZZZ

LUMINAIRE DATA

Test No.	20859
Description	UTB2 High Bay with Open-Bottom OP16 Reflector
Delivered Lumens	25,215
Watts	160.10W
Efficacy	157
Mounting	Pendant
Spacing Criterion	(0-90) 1.15

ZONAL LUMEN SUMMARY

Zone	Lumens	% Luminaire
0-30	8471	33.6
0-40	12966	51.4
0-60	17724	70.3
0-90	23308	92.4
0-180	25215	100.0

POLAR GRAPH

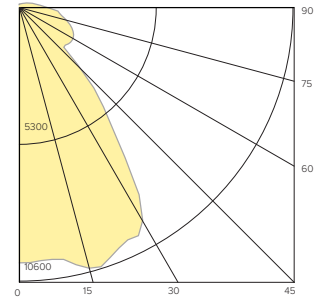

UTB2-8-50-MHHE-WW-X-SB16-N-YY-ZZZZ

LUMINAIRE DATA

Test No.	20863
Description	UTB2 High Bay with Open-Bottom SB16 Reflector
Delivered Lumens	25,397
Watts	160.10W
Efficacy	159
Mounting	Pendant
Spacing Criterion	1.33

ZONAL LUMEN SUMMARY

Zone	Lumens	% Luminaire
0-30	8663	34.1
0-40	13,195	52.0
0-60	17,692	69.7
0-90	22,874	90.1
0-180	25,397	100.0

POLAR GRAPH

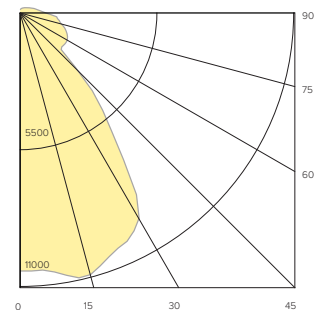

PHOTOMETRY (CONTINUED)

UTB2-8-50-MHHE-WW-X-WA16-N-YY-ZZZZ

LUMINAIRE DATA

Test No.	20850
Description	UTB2 High Bay with Open-Bottom WA16 Reflector
Delivered Lumens	25,259
Watts	160.10W
Efficacy	158
Mounting	Pendant
Spacing Criterion	(0-90) 1.18

ZONAL LUMEN SUMMARY

Zone	Lumens	% Luminaire
0-30	9762	38.6
0-40	14,425	57.1
0-60	21,455	84.9
0-90	24,176	95.7
0-180	25,259	100.0

POLAR GRAPH

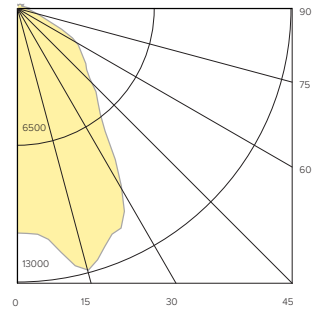

UTB2-8-50-MHHE-WW-X-WW16-N-YY-ZZZZ

LUMINAIRE DATA

Test No.	20855
Description	UTB2 High Bay with Open-Bottom WW16 Reflector
Delivered Lumens	23,417
Watts	160.10W
Efficacy	146
Mounting	Pendant
Spacing Criterion	(0-90) 1.35

ZONAL LUMEN SUMMARY

Zone	Lumens	% Luminaire
0-30	9320	39.8
0-40	14,163	60.5
0-60	18,616	79.5
0-90	21,567	92.1
0-180	23,417	100.0

POLAR GRAPH

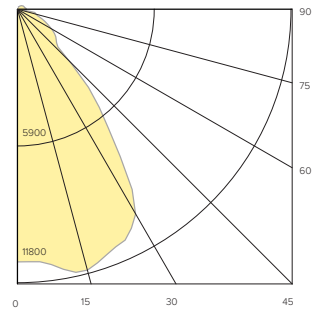

ELECTRICAL DATA

LUMEN PACKAGE	NOMINAL LUMENS	AMBIENT TEMPERATURE		NOMINAL INPUT WATTS	AMPERAGE						POWER FACTOR		THD	
		120-277V	347/480V		120V	208V	240V	277V	347V	480V	120-277V	347/480	120-277V	347/480
LX	12,000	-35°C to 65°C	-40°C to 65°C	84	0.72	0.40	0.36	0.31	0.24	0.18	0.99	0.96	9.5	9.3
LXHE	12,000			79	0.66	0.39	0.34	0.29	0.23	0.17	0.99	0.96	9.7	9.5
MM	18,000			128	1.09	0.62	0.55	0.48	0.36	0.27	0.99	0.96	11.8	11.5
MMHE	18,000			119	1.02	0.59	0.52	0.46	0.35	0.26	0.99	0.96	9.7	9.5
MH	24,000	-35°C to 55°C	-40°C to 55°C	168	1.43	0.82	0.71	0.62	0.48	0.35	0.99	0.96	10.0	9.8
MHHE	24,000			160	1.36	0.79	0.69	0.60	0.46	0.33	0.99	0.96	9.7	9.5
MVHE	30,000			190	1.58	0.91	0.79	0.69	0.55	0.40	0.99	0.96	9.7	9.5

DIMENSIONS
No Lens

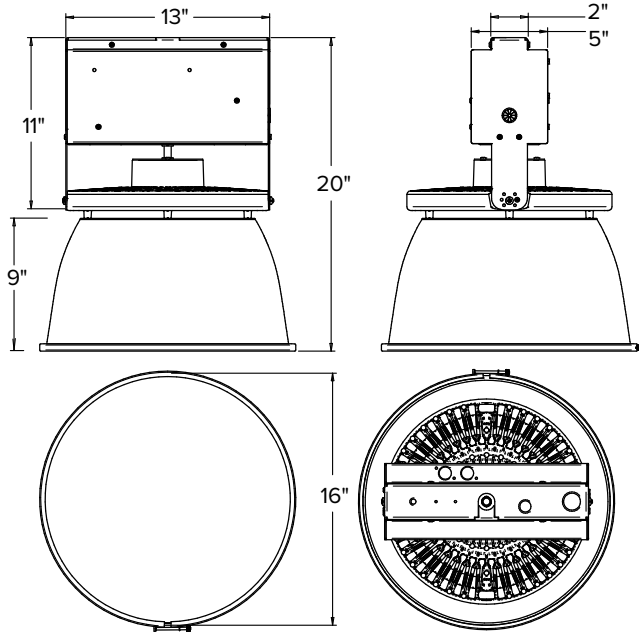

Conical Drop Lens (CDL)

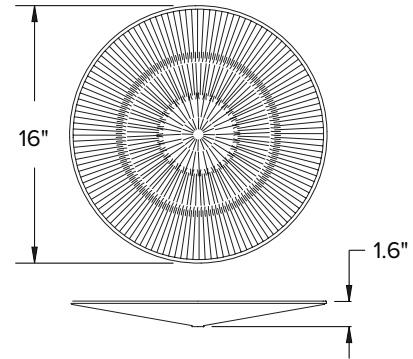

Dropped Lens Refractor (DLR)

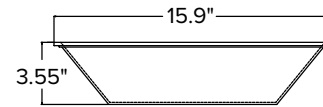

DTS WIRING DIAGRAM

DTS WIRING DIAGRAM (0-10V DIMMING DRIVER SHOWN)

