

VLA2-Caltrans Model LED Signal Modules

12 inch

Incandescent look (120V)



Project Name _____

Date _____ Type _____

Notes _____

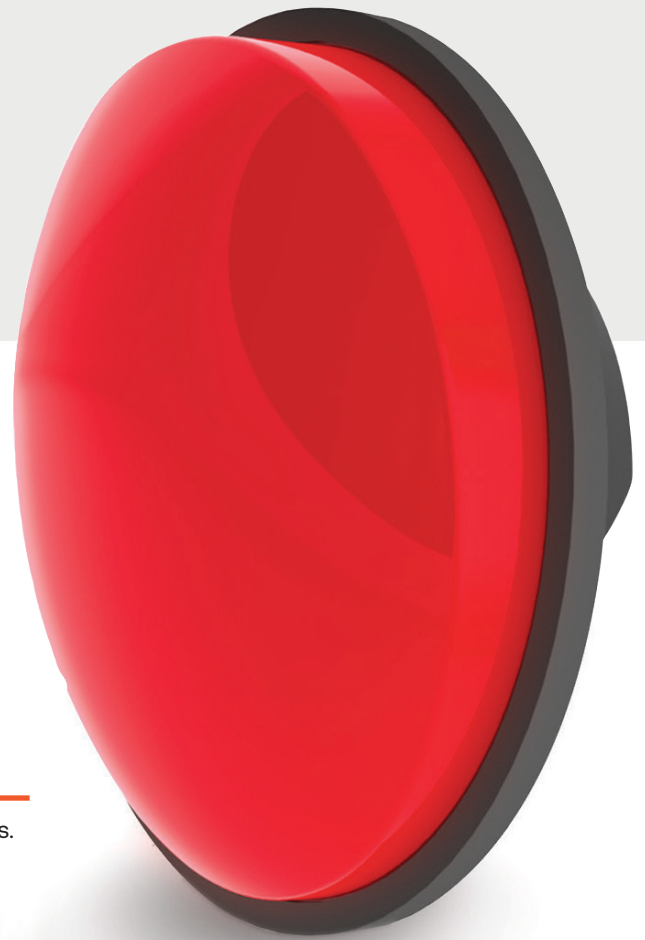

ROBUST FEATURES

- Optimal thermal management for longer life.
- Provides performance under extreme field temperature conditions.

INNOVATIVE DESIGN

- Low profile module permits efficient installation into existing traffic housings.
- Power consumption levels allow compatibility with most controllers.

OUTSTANDING PERFORMANCE

- High-brightness central light source and custom optical lensing distribute light uniformly and efficiently.
- Rigorously tested for long life design and low maintenance costs.
- Excellent color uniformity.

MEETS RIGOROUS CERTIFICATION & TESTING STANDARDS

- CEC listed.
- Listed on CALTRANS AML



The Greatest Signals Stand the Test of Time.™

GTX™ City (CALTRANS)

LED Signal Modules

12 inch

Project Name _____

Date _____ Type _____

Notes _____

Mechanical Outline Dimensions in inches (mm)

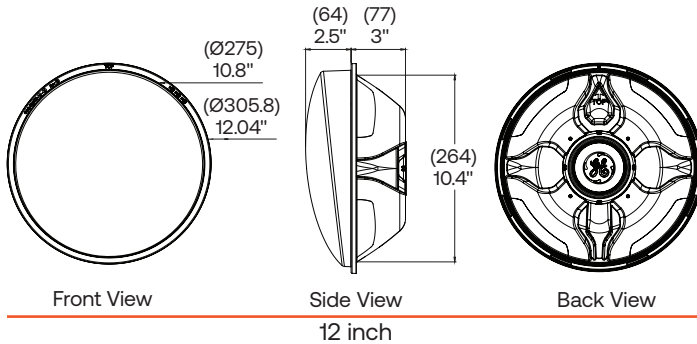

Design Compliance

Test type	Compliance
Moisture Resistance	Blown Wind Rain MIL-STD-810F method 506.4
Mechanical Vibration	MIL-STD-883 Method 2007
Electronic Noise	FCC Title 47 Sub. B Sec 15 ¹
Transient Voltage Protection	Sec. 2.1.6 NEMA TS2-2003, 300V, 2500W Sec. 2.1.6 NEMA TS2-2003, 600V, 10µF Sec. 2.1.8 NEMA TS2-2003, 1kV, 2Ω
Controller Compatibility	ITE VTCSH-LED Circular Signal Supplement-June 2005
Wiring	NFPA 70, National Electric Code
Transient Suppression	Sec. 8.2 IEC 61000-4-5 & Sec. 6.1.2 ANSI/IEEE C62.41.2 - 2002, 3KV, 2 Ω Sec. 8.0 IEC 61000-4-12 & Sec. 6.1.1 ANSI/IEEE C62.41.2 - 2002, 6KV, 30 Ω
Immunity	Radiated electromagnetic field immunity - radio frequencies IEC 6100-4-3:2020 10 V/m (80 MHz-1 GHz) - Class A

Operating Specifications

Parameter	Rating
Operating Temperature Range*	-40 to +74°C (-40 to +165°F)
Operating Voltage Range	80 to 135 V (60Hz AC)
Power Factor (PF)	> 90%
Total Harmonic Distortion (THD)	< 20%
Minimum Voltage Turn-Off (VTO)	35 V
Turn-On/Turn-Off Time	< 75 ms
Lens & Shell Material	UV Stabilized Polycarbonate
Wiring	12 in lamp: 40 in, 18 AWG, Color Coded with Strain Relief

* Operating Temperature Range per ITE 2005, Section 3.3.2

Product Information

Model Number	Front Shell	Size (in)	AC Voltage Nominal	Power (W) Nominal	Wavelength (nm) Nominal	Maintained Intensity (Cd) Minimum ^{2,3}
DR6-RTFB-VLA2	Tinted	12	120V - 60Hz	8.5	625	365
DR6-RCFB-VLA2	Clear					
DR6-YTFB-VLA2	Tinted	12	120V - 60Hz	12	589	910
DR6-YCFB-VLA2	Clear					
DR6-GTFB-VLA2-032	Tinted	12	120V - 60Hz	9	501	678
DR6-GCFB-VLA2-032	Clear					

Distributed by:

Standard product equipped with universal connectors (insulated spade-quick disconnect).

All colors available in tinted or clear lens.

¹ Class A

² For Red and Yellow Signals: Measured at vertical angle of -2.5° and at horizontal angle of 0°

³ For Green Signals: Measured at vertical angle of 2.5° and at horizontal angle of ±2.5°