



LBT 24 Series

2'x4' LED Recessed Volumetric T-Grid

The Lumination® LBT series is ideal for commercial ceilings providing high uniformity, excellent efficiency and reduced glare for T-grid ceiling applications. Suitable for indoor general lighting for both new construction and retrofit luminaire replacements. The uniform light across the lens offers a distinctive, better look than traditional LED “two strip troffers”. Because of the thin frame, this luminaire fills the ceiling grid square with “light.”

CONSTRUCTION

Housing:	Durable, long lasting bezel construction. Steel, galvanized, cold-rolled, commercial quality.
Lens:	Precision formed optical assembly comprised of high specular reflective paint
Paint:	Post painted powder coat finish on housing
Weight:	<16 pounds

OPTICAL SYSTEM

Lumens:	Up to 7,200 lumens
Wattage:	Up to 56 Watts
Efficacy:	Up to 133 LPW
CCT:	3500K/4000K/5000K
CRI:	80+, R9 >0
Color Consistency:	Central limit 4-Step MacAdam Ellipse with LED recipe approach for tight unit to unit color control

ELECTRICAL

Input Voltage:	120-277V, 347V
Input Frequency:	50/60Hz
Standard Dimming Control:	0-10V, Dimming
Power Factor (PF)*:	> 0.9%
Total Harmonic Distortion (THD)*:	< 20%
LED Driver Type:	Class 2

* PF and THD may vary with options

CONTROLS

Dimming:	Standard - 0-10V Dimming
Minimum Dimming:	5% of rated lumen LED Current driver
Sensors:	Daintree Compatible (see Ordering Information for additional info)

LUMEN AMBIENT TEMPERATURE

TYPE	TEMPERATURE RATE
OPERATING TEMPERATURE	-20°C to +35°C (-4°F to +95°F)
STORAGE TEMPERATURE	-40°C to +70°C (-40 °F to +158°F)

LUMEN MAINTENANCE

LXX(10K) @ Hours
50,000 HR
L85

ADDITIONAL FEATURES

- **Typical Mounting:** Fits standard T-Bar grid (drop ceilings)
- **Wiring Access:** ½" trade-size KO's on removable access plate provided
- **T-Grid Clips:** T-Grid clips included, with holes for seismic wires
- **Surface Mounting:** Surface mount kit available
- **Optional Emergency Battery:** Provides 90-minutes of Emergency lighting. Note, EL option is not available with 347V option. Initial design lumen output: 1400 lumens
- **Optional Chicago Plenum:** Openings in recessed fixture sealed per requirements for CCEA
- **Optional Bypass Relay:** Overrides dimming when emergency generator is used (see ordering notes for limitations)

DESIGN LIFE & WARRANTY

- Damp Location rated
- UL/cUL Listed
- RoHS compliant
- ANSI C82.77 Compliant
- Reliability Testing: Components and systems evaluation
- Current's Limited Warranty: System Warranty: 5 Year (Please see website)



LBT 24 Series

2'x4' LED Recessed Volumetric T-Grid

CUSTOMER NAME

Project Name _____

Date _____ Type _____

Catalog Number _____

Ordering Information¹

LBT 24 A MM LT WHITE

FAMILY	FIXTURE TYPE	GENERATION	VOLTAGE	NOMINAL LUMENS	DISTRIBUTION	CRI/CCT	CONTROLS ²	MOUNTING	FINISH	OPTIONS
LBT = Lumination® Backlit T-Grid	24 = 2' x 4'	A = 1 st Generation	0 = 120-277V D = 347V	30 = 3000 40 = 4000 48 = 4800 60 = 6000 72 = 7200	MM = Med. Lambertain	835=80 CRI, 3500K 840=80 CRI, 4000K 850=80 CRI, 5000K ¹	VQ= 0-10V Dimming TQ= Daintree Wireless Enabled ² TS= Daintree Wireless Enabled with Daintree WFA100 SQ = Digital Input Driver (does not have 0-10v input) that uses a field installed accessory (in the ceiling -not the fixture) that is Daintree compatible such as Daintree One, EZ Connect or Enterprise sensors	LT= T-Grid	WHITE= White	(blank) = None CP= Chicago Plenum EL= Emergency Battery B2 ³ = Emergency Bypass ³ – Dual Shunt Relay to be used with building generator backup systems to override dimming

ORDERING NOTES:

- Contact manufacturer for lead times
- Most commonly ordered for Daintree Enterprise Wireless Enabled
- Not available on VQ control option
- Most Standard base SKU's are DLC, there are exceptions for 347V and EL for meeting PF and/or THD results. Please check the DLC QPL

ACCESSORIES	DESCRIPTION CODE	PRODUCT CODE
Drywall Mount Kit 2x4	GESK11	69523
2x4 Surface Mount Kit for Backlit T-Grid	B24 SMK	212463

EXAMPLE CONFIGURATIONS	LUMINAIRE LUMENS	LUMINAIRE TOTAL SYSTEM WATTS	LPW
LBT24A030MM835VQLTWHITE	3000	22.5	133
LBT24A040MM835VQLTWHITE	4000	30.0	133
LBT24A048MM835VQLTWHITE	4800	36.0	133
LBT24A060MM835VQLTWHITE	6000	45.5	132
LBT24A072MM835VQLTWHITE	7200	56.0	129
LBT24A030MM840VQLTWHITE	3000	22.5	133
LBT24A040MM840VQLTWHITE	4000	30.0	133
LBT24A048MM840VQLTWHITE	4800	36.0	133
LBT24A060MM840VQLTWHITE	6000	45.5	132
LBT24A072MM840VQLTWHITE	7200	56.0	129
LBT24A030MM850VQLTWHITE	3000	22.5	133
LBT24A040MM850VQLTWHITE	4000	30.0	133
LBT24A048MM850VQLTWHITE	4800	36.0	133
LBT24A060MM850VQLTWHITE	6000	45.5	132
LBT24A072MM850VQLTWHITE	7200	56.0	129

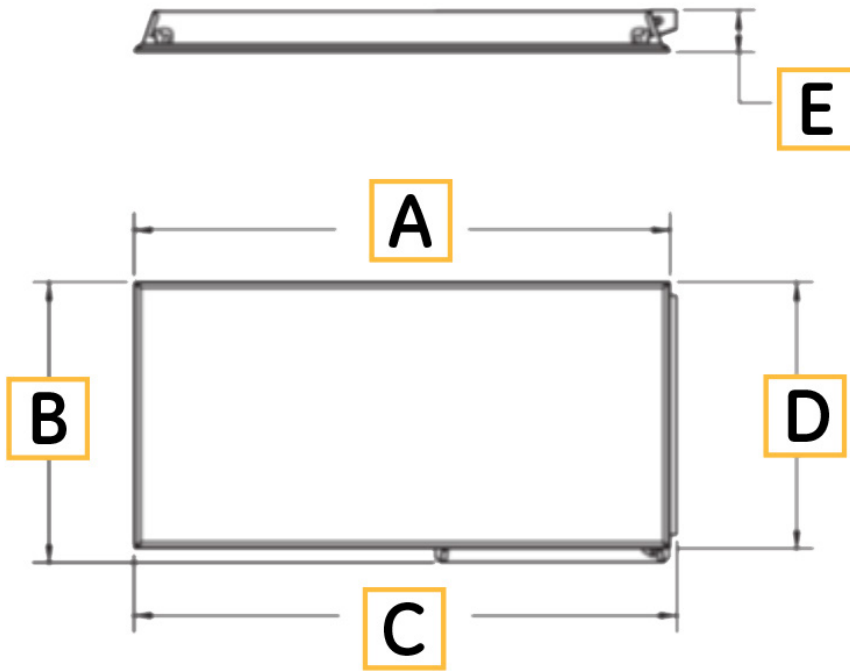
DIMENSIONS

A = 47.18in (1214mm)
B = 25.10in (638mm)
C = 48.38in (1229mm)
D = 23.82in (605mm)
E = 3.76in (96mm)

PHOTOMETRIC DATA

ZONAL LUMEN SUMMARY	
ZONE	LUMENS
0-10°	152.79
10-20°	439.27
20-30°	669.29
30-40°	813.04
40-50°	851.97
50-60°	779.97
60-70°	606.61
70-80°	364.45
80-90°	112.46
90-100°	2.01
100-110°	1.32
110-120°	1.28
120-130°	1.24
130-140°	1.23
140-150°	1.13
150-160°	0.95
160-170°	0.71
170-180°	0.25

ZONAL LUMEN SUMMARY				
ZONE	LUMENS	% OF LAMP	% OF FIXTURE	
0-20°	592.06	N.A.	12.30	
0-30°	1261.35	N.A.	26.30	
0-40°	2074.38	N.A.	43.20	
0-60°	3706.33	N.A.	77.20	
0-80°	4677.39	N.A.	97.40	
0-90°	4789.85	N.A.	99.80	
10-90°	4637.05	N.A.	96.60	
20-40°	1482.32	N.A.	30.90	
20-50°	2334.30	N.A.	48.60	
40-70°	2238.55	N.A.	46.60	
60-80°	971.06	N.A.	20.20	
70-80°	364.45	N.A.	7.60	
80-90°	112.46	N.A.	2.30	
90-110°	3.33	N.A.	0.10	
90-120°	4.61	N.A.	0.10	
90-130°	5.85	N.A.	0.10	
90-150°	8.22	N.A.	0.20	
90-180°	10.13	N.A.	0.20	
110-180°	6.80	N.A.	0.10	
0-180°	4799.97	N.A.	100.00	

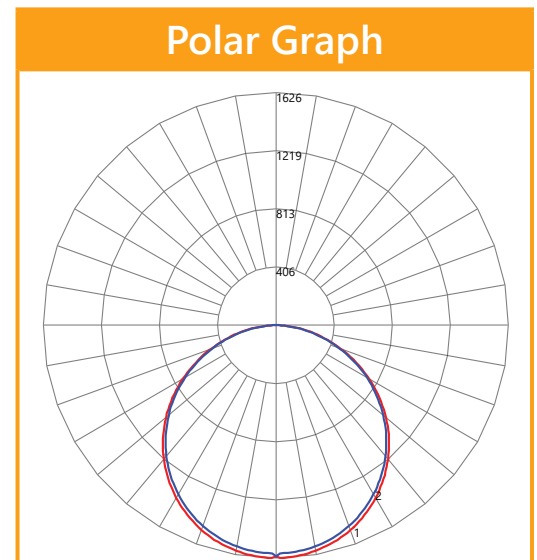

CUSTOMER NAME

Project Name _____

Date _____ Type _____

Catalog Number _____

DAINTREE CONTROLS

Daintree® Wireless Controls:

There is no one size fits all for wireless controls. Some networks want simple solutions that reduce energy consumption and meet code compliance while others are more ambitious, looking to capitalize on the LED and controls savings to fund a scalable, enterprise-grade, internet of things solution. The advantage of the Daintree® Wireless platform is it's ability to integrate into indoor, outdoor and high bay environments. The Daintree® Wireless Controls provide the infrastructure to future proof your buildings, easily upgrade to Networked solutions and provide the ability to integrate into IoT solutions that are right for your business.

- **Daintree® One:** Standalone Wireless Controls
- **Daintree® EZ Connect:** Room-Based Wireless Lighting Controls
- **Daintree® Networked:** Networked Lighting Controls for Smart Building & IoT Enablement

Daintree® Wireless Controls are already integrated in your favorite Current LED fixtures. Integrating the controls into the fixture cuts labor costs considerably since the sensors are already embedded in the lighting fixtures. There's no need to go above the ceiling plenum and install additional devices. Visit our website LED.com for a complete list of LED Fixtures.

For Product or Technical Questions:

Email: lightingproinfo@currentlighting.com

Phone: +1 888 694 3533, option 2