

DATE: _____ LOCATION: _____

TYPE: _____ PROJECT: _____

Notes: _____

ELWG Series

Mesh Getaway

Outdoor Lighting Control System Designed for Street and Roadway Applications. It enables remote monitoring, control, and asset management of a single fixture or a group of fixtures through a web enabled Central Management System.



SYSTEM ARCHITECTURE

Nodes reside on top of each light fixture on a standard ANSI socket and operate in a mesh network, communicating to each other as well as the gateway. The Gateway connects nodes to the Central Management System through a standard TCP-IP interface.

Current offers an RF simulation to determine the optimal placement of where gateways will be installed to maximize the node to gateway connectivity.



WHY MESH?

Mesh systems provide a cost-effective lighting controls solution in urban environments that typically have dense pole locations, because each gateway can support up to 550 nodes.

- Optimized Energy Usage: *On/Off & Dimming*
- Query by Location: *Data is available every 15 Minutes but manual query is sent immediately.*
- Reduce and Streamline Repair Calls: *Day Burner/Dark Night Alerts allows the user to customize alarm configurations for added flexibility.*
- Accurate Energy Usage Measurement: *+/- 0.5% Accuracy*

PRODUCT FEATURES

Communication hub for self-forming & self-restoring node mesh network to central command

Built-in Cell Modem

Integrated GPS for 4G Gateway Registration and Location Display in Control Software

Enhanced Surge Protection 6kV/3kA per ANSI C136.2-2015

Real-time update of the status of all the fixtures

Static IPv6 Addressing and Routing

Industry Standard Secure Encrypted Communications

Ethernet Port Available

DATE:	LOCATION:
TYPE:	PROJECT:
Notes:	

CATALOG # **ELWG-**

ELWG	Voltage	Antenna	Location	GPS	Cellular Network	Generation	Options
ELWG	0 120-277V	C Standard 18	XX Default	G Default	M Modern ATT	Blank 3G G 4G	None Default

Examples

ELWGOCCXXGMG: 4G Gateway 120-277V, Standard Antenna, GPS 4G Gateway with Modem configured for ATT , Network A

NODE SPECIFICATIONS

Input Voltage: 120-277V
Operating Temp: -40° to +70°C
Surge Protection: 10kV/5kA Standard, per ANSI C136.2-2015
Power Consumption: typical 4W
GPS Accuracy: +/- 3m in clear open sky
Addressing: IPv6 protocol
Security: AES Encryption and Certificate Based Authentication

HOUSING & CONSTRUCTION

Ingress Protection: Class IP65
Weight: 7 lbs

NETWORK, COMPLIANCE & SECURITY

Radio Frequency: 915 MHz ISM Band, FCC CFR 47 15.247 Intentional Radiators, ICES-005
Network Communication: IEEE 802.15.4 6LoWPAN, 50 Channel FHSS
EMI: Complies with FCC CFR 47 15.208, 15.209 and ICES-005 (B)/ NMB-005 (B)

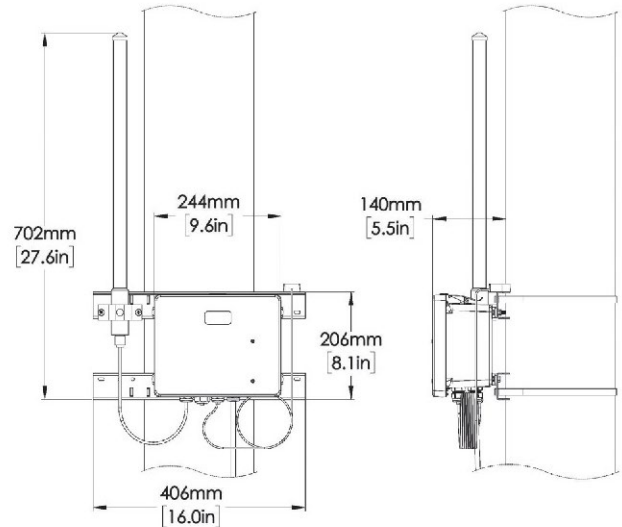

WARRANTY

5 Year (Standard)

10 Year (Extended)