

DATE: \_\_\_\_\_ LOCATION: \_\_\_\_\_  
 TYPE: \_\_\_\_\_ PROJECT: \_\_\_\_\_  
 CATALOG #: \_\_\_\_\_

**FEATURES**

- Switchable Lumen technology: 4000/3300/2800 lumens (2x2)
- Switchable CCT technology: 3500/4000/5000K
- 80 CRI
- 0–10V dimming to 10%
- Recessed, surface, or cable mount
- Universal voltage (120–277V)
- IC rated
- Suitable for ISO Class 5–9 positive pressure and negative cleanrooms



**SPECIFICATIONS**

**CONSTRUCTION**

- Extruded aluminum frame has a matte white finish and smooth frame-to-lens transition

**OPTICS**

- Acrylic blend light guide with frosted/textured outer lens provides edge to edge illumination without pixelation or bright spots

**INSTALLATION**

- Integral T-bar clips for secure mounting to grid ceiling
- For surface/cable mount applications use surface/cable mount kit accessories
- For plaster or sheet rock installations, use flange kit

**ELECTRICAL**

- 54,000 hour LEDs at L70 for reduced maintenance
- Switchable Lumen technology allows for easy field-adjustable lighting output with three level switch located on back of panel
- Switchable Lumen fixtures ship at the highest lumen output setting
- Operates at 120-277V input
- 0–10V dimmable driver, down to 10%

**CERTIFICATIONS**

- All luminaires are built to UL 1598 standards and bear appropriate cULus labels
- UL Sanitation Certified to NSF 2 Food Equipment standard for non-food zones

**CERTIFICATIONS (CONTINUED)**

- CSA certified to UL 924 standards with battery pack
- Damp location label standard
- Tested in accordance with ISO 14644-1; suitable for ISO Class 5–9 positive and negative pressure clean rooms
- Adheres to LM79, LM80, and TM21 industry standards for photometrics and lifetime calculations
- DLC® (DesignLights Consortium Qualified, with some Premium Qualified configurations. Please refer to the DLC website for specific product qualifications at [www.designlights.org](http://www.designlights.org))

**WARRANTY**

- 5 year warranty

**ORDERING GUIDE**

Catalog No.	Part #	UPC	Description	Setting	Lumens			Watts			LPW		
					3500K	4000K	5000K	3500K	4000K	5000K	3500K	4000K	5000K
<input type="checkbox"/> CFP22-LSCS	93133732	840141421919	2x2 Edge-Lit Panel, 4000/3300/2800 Switchable Lumens, 3500/4000/5000K Switchable CCT	LOW	3174	3225	3137	24	130	137	130		
				MED	3603	3679	3562	28	128	135	127		
				HIGH	4381	4477	4291	35	124	133	123		
<input type="checkbox"/> CFP24-41CS-HE	93133738	840141421971	2x4 Edge-Lit Panel, 4100 Lumens, 3500/4000/5000K Switchable CCT	—	4428	4507	4420	35	127	129	126		

**Made to Order (MTO) Options:**  
 Add **ELL14** (Emergency Battery Pack Installed, 1400 Lumens) or **C588** (5-wire Flex) to any stocked option.  
 Examples: **CFP14-LSCS-ELL14**; **CFP14-LSCS-C588**

SEE FOLLOWING PAGE FOR CFP ACCESSORIES

KEY DATA	
Lumen Range	3137–6065
Wattage Range	24–49
Efficacy Range (LPW)	110–134
Reported Life (Hours)	L70/54,000

# CFP-LSCS

EDGE-LIT FLAT PANEL

DATE: \_\_\_\_\_ LOCATION: \_\_\_\_\_

TYPE: \_\_\_\_\_ PROJECT: \_\_\_\_\_

CATALOG #: \_\_\_\_\_

## ORDERING GUIDE

Accessories (Order Separately)	
<b>PLD10M</b>	Dual-Lite® Emergency LED Battery Pack, field installed <sup>1</sup>
<b>PLRTS</b>	Remote Test Switch/Charge Indicator Module (fits single-gang box)
<b>FK14</b>	1x4 Single Flange Kit
<b>FK22</b>	2x2 Single Flange Kit
<b>FK24</b>	2x4 Single Flange Kit
<b>PSMK-14</b>	1x4 Flat Panel Surface Mount Kit
<b>PSMK-22</b>	2x2 Flat Panel Surface Mount Kit
<b>PSMK-24</b>	2x4 Flat Panel Surface Mount Kit
<b>CFPCM36Y SC5F-KIT</b>	36" Cable Mount Kit for 1' or 2' wide Cable Mount fixtures, 5-wire

Notes:

1 Fixtures with Emergency Battery Pack require a remote-mounted test switch, we suggest the Dual-Lite PLRTS.

**DIMENSIONS**

**2'x2' Recessed Mount**

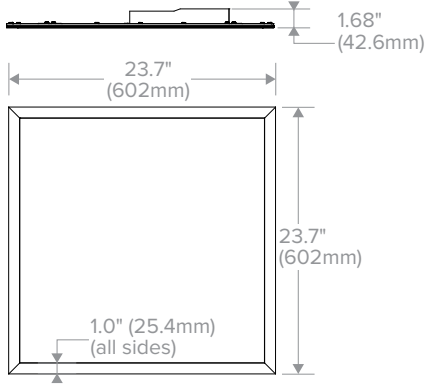

**2'x2' Surface Mount**

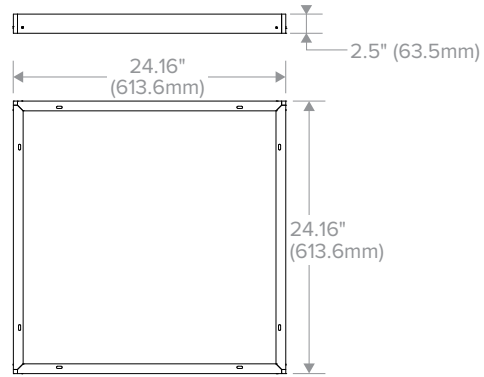

**2'x4' Recessed Mount**

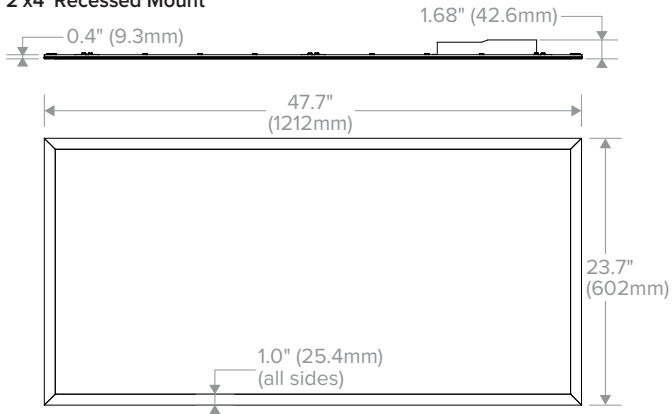

**2'x4' Surface Mount**

